

 **FlexNet**™

Network Intelligent Analog Fire Alarm and Audio System





# Table of Contents

---

|  |           |
|--|-----------|
| <b>Introduction .....</b>  | <b>1</b>  |
| <b>Additional Features.....</b>                                      | <b>3</b>  |
| <b>Document Conventions.....</b>                                     | <b>3</b>  |
| <b>System Components .....</b>                                       | <b>6</b>  |
| <b>Mechanical Installation and Dimensions .....</b>                  | <b>14</b> |
| <b>BBX-1024XT/R Mechanical Installation.....</b>                     | <b>17</b> |
| <b>Module Mounting Locations .....</b>                               | <b>20</b> |
| <b>Display and Adder Modules Mounting Locations.....</b>             | <b>22</b> |
| <b>Module Settings .....</b>   | <b>26</b> |
| <b>Field Wiring.....</b>   | <b>42</b> |
| Main Fire Alarm Module Terminal Connections.....                     | 42        |
| Analog Loop Wiring.....  | 44        |
| FNC-2000 Fire Network Controller Module.....                         | 50        |
| FOM-2000-SP Fiber Optic Network Adder Module.....                    | 51        |
| Detection Module (DM-1008A) Terminal Connections .....               | 52        |
| Signal Module (SGM-1004A) Terminal Connections .....                 | 53        |
| Relay Module (RM-1008(A)) Terminal Connections .....                 | 54        |
| Polarity Reversal and City Tie Module (PR-300) Wiring .....          | 55        |
| UDACT-300A Main Board Terminal Connections.....                      | 56        |
| Power Supply Connections.....  | 57        |
| Wiring Tables and Information .....                                  | 58        |
| <b>System Checkout.....</b>  | <b>60</b> |
| <b>Indicators, Controls, and Operation.....</b>                      | <b>61</b> |
| <b>Configuration.....</b>  | <b>70</b> |
| <b>Typical Flex-Net™ System Layouts with Audio .....</b>             | <b>71</b> |
| <b>System Components for the Integrated Fire/Audio Cabinet.....</b>  | <b>73</b> |
| Network Fire Alarm .....   | 73        |
| Network Controller Modules.....                                      | 73        |
| Fiber Optics Module.....   | 74        |
| Adder Modules.....   | 74        |
| Auxiliary Modules.....   | 74        |
| Programmable Modules.....  | 74        |
| <b>Flex-Net™ Mass Notification System (BBX-FXMNS) Enclosure.....</b> | <b>75</b> |
| <b>Mechanical Installation for the Expansion Audio Cabinet .....</b> | <b>79</b> |
| QBB-5001/R Expansion Audio Cabinet Installation .....                | 79        |
| <b>BBX-FXMNS Audio Module Placement and Internal Wiring .....</b>    | <b>80</b> |
| <b>Integrated Fire Alarm Connection .....</b>                        | <b>81</b> |
| Battery Power .....  | 81        |
| Transformer Power .....  | 81        |
| <b>QBB-5001/R Expansion Audio Cabinet Module Placement .....</b>     | <b>82</b> |
| QPS-5000N Power Supply Connection .....                              | 83        |
| <b>Installing and Removing Amplifiers.....</b>                       | <b>84</b> |
| Installing QAA Amplifier Modules.....                                | 84        |
| Removing the QAA Amplifier Modules.....                              | 84        |
| <b>Multiple QBB-5001/R Cabinet Connections.....</b>                  | <b>84</b> |
| QMB-5000B Motherboards #1, #2, and #3 .....                          | 84        |
| <b>Audio Network Card and Telephone Network Card.....</b>            | <b>86</b> |
| <b>Audio Amplifier Wiring .....</b>                                  | <b>87</b> |
| QAA-5230-70/25 Amplifier Wiring.....                                 | 87        |
| QAA-5230S-70/25 Amplifier Wiring .....                               | 88        |
| QAA-5415-70 and QAA-5415-25 Amplifier Wiring.....                    | 89        |
| QAA-5160-70/25 .....   | 93        |
| Backup Amplifier .....   | 95        |

|  |            |
|--|------------|
| <b>Displays &amp; Controls</b> .....   | <b>96</b>  |
| Amplifier Displays.....  | 96         |
| <b>Setup</b> .....   | <b>97</b>  |
| QBB-5001/R Amplifier Installation.....   | 97         |
| Before Turning the Power "ON" .....  | 97         |
| <b>Audio Configuration</b> .....   | <b>97</b>  |
| <b>Lobby Enclosures</b> .....  | <b>98</b>  |
| <b>ANC-5000 Audio Network Controller Module</b> .....                                | <b>99</b>  |
| <b>ANC-5000 Wiring</b> .....   | <b>100</b> |
| <b>QMP-5101NV Vertical Paging Control Module</b> .....                               | <b>102</b> |
| <b>Paging Modules</b> .....  | <b>103</b> |
| QMP-5101N Network Master Paging Control Module .....                                 | 103        |
| <b>QMP-5101N/V Network Paging Wiring</b> .....                                       | <b>105</b> |
| QAZT-5302DS Zoned Paging Selector Panel.....   | 106        |
| <b>Paging Operation</b> .....  | <b>106</b> |
| QMP-5101N/QMP-5101NV LEDs .....  | 106        |
| QMP-5101N/QMP-5101NV Pushbutton Controls .....                                       | 107        |
| QAZT-5302/DS Paging Selector Panel LEDs .....  | 107        |
| QAZT-5302/DS Pushbuttons .....   | 107        |
| <b>TNC-5000 Telephone Network Controller Module</b> .....                            | <b>108</b> |
| <b>Module Mounting Locations</b> .....   | <b>108</b> |
| Typical Addressable Telephone Set-up .....   | 109        |
| <b>Connectors and Terminal Locations</b> .....                                       | <b>110</b> |
| <b>TNC-5000 Telephone Wiring</b> .....   | <b>111</b> |
| <b>QMT-5302NV Vertical Master Telephone</b> .....                                    | <b>113</b> |
| <b>QMT-5302N Master Firefighters' Telephone</b> .....                                | <b>114</b> |
| <b>QMT-5302N Connections</b> .....   | <b>115</b> |
| <b>QAZT-5302DS Network Firefighters' Telephone Selector Panel</b> .....              | <b>116</b> |
| <b>Telephone Operation</b> .....   | <b>118</b> |
| QMT-5302N and QMT-5302NV Master Telephone LEDs .....                                 | 118        |
| QMT-5302N and QMT-5302NV Master Telephone Pushbutton Controls.....                   | 118        |
| QAZT-5302DS Network Firefighters' Telephone Selector Panel LEDs .....                | 118        |
| QAZT-5302DS Network Firefighters' Telephone Selector Panel Pushbutton Controls ..... | 118        |
| <b>Appendix A: Specifications</b> .....  | <b>119</b> |
| Compliance .....   | 120        |
| ULI/ULC Integrated Fire Alarm and Audio Panel Specifications .....                   | 121        |
| <b>Appendix B: Power Supply and Battery Calculations</b> .....                       | <b>123</b> |
| RAXN-LCD/RAXN-LCDG:.....   | 124        |
| <b>Appendix C: DIP Switch Settings</b> .....   | <b>125</b> |
| ANC-5000 Board with Ethernet Port, Address Setting (DIP SWITCH SW1) .....            | 126        |
| ANC-5000 Board without Ethernet Port, Address Setting (DIP SWITCH SW1) .....         | 126        |
| ACN-792M Loop Adder Module (CPU) Address Setting (DIP SWITCH SW1) .....              | 126        |
| RAXN-LCD/RAXN-LCDG Remote Annunciator Address Setting (DIP SWITCH SW1) .....         | 126        |
| <b>Appendix D: Alarm Verification Timing</b> .....                                   | <b>126</b> |
| <b>Appendix E: Wiring For Addressable Supervised Output Module</b> .....             | <b>127</b> |
| <b>Appendix F: ULC Compatible Speakers</b> .....                                     | <b>128</b> |
| <b>Appendix G: ULI Compatible Speakers</b> .....                                     | <b>129</b> |
| <b>Appendix H: Power Supply &amp; Batteries for Audio</b> .....                      | <b>130</b> |
| <b>Appendix I: FXMNS Used as a Mass Notification System (ACU)</b> .....              | <b>131</b> |
| <b>QMP-5101N Network Paging Wiring for Mass Notification</b> .....                   | <b>132</b> |
| <b>Configuration for Mass Notification</b> .....                                     | <b>133</b> |
| <b>ACU Emergency Response Operation</b> .....  | <b>135</b> |
| <b>Appendix J: APB-200/COA Sounder Bases</b> .....                                   | <b>136</b> |
| <b>Warranty &amp; Warning Information</b> .....                                      | <b>137</b> |

# Introduction

---

## About the Flex-Net™ Network Fire and Emergency Communication System

Mircom's Flex-Net™ Intelligent Fire Alarm and Audio Network offers modular components for network systems providing a wide variety of applications. Designed for peer to peer network communications, using industrial standard ARCnet protocol. Flex-Net™ allows for a maximum of 63 nodes (where a node can be a control center or a floor panel) while providing reliability and flexibility.

Flex-Net™ is based on the proven and reliable FX-2000 Fire Alarm Control Panel platform. Each base panel consists of one intelligent analog loop controller capable of supporting 159 Advanced Protocol (AP) analog sensors and 159 AP addressable modules (with a maximum of 99 CLIP sensors and 99 CLIP addressable modules). For example, if there are 99 CLIP (non AP) sensors on a loop, you may add an additional 60 AP sensors for a total of 159. NOTE: AP sensors and monitors can be set as a CLIP sensors and monitors for retrofit use. The base panel also consists of 4 Class A/B (Style Z/Y) Indicating Circuits (NACs) rated at 1.7 amperes each and a large 4 x 20 back-lit alphanumeric LCD display.

The Flex-Net™ configuration allows the Flex-Net™ Fire Alarm Control Panels to be connected to a Mircom network which provides additional input circuits, visual zones, programmable notification appliance circuits and relays. In addition, a Flex-Net™ Integrated Fire and Audio panel can be used to provide a fully distributed audio and/or integrated telephone system.

Mircom's Flex-Net™ Network system also provides zoned emergency multi-channel audio providing emergency paging and fire evacuation, and an optional firefighters' telephone communication to and from CACF (Central Alarm and Control Facilities) location to all remote telephone handsets. The system consists of Integrated Fire and Audio Network Panel or FX-MNS nodes. Each Integrated Fire and Audio Network Panel or FX-MNS contains an audio portion which consists of a QMB-5000N motherboard and card cage which holds an ANC-5000 Audio Network Card, a TNC-5000 Telephone Network Card and up to 4 amplifiers, a fire alarm portion FX-2000MNS Main Chassis, a PS-2040 power supply and batteries. The QBB-5001/R expansion audio cabinet (connected to a Integrated Fire and Audio Network Panel or FX-MNS node) contains a card cage motherboard which holds up to 7 amplifiers, has an audio power supply, battery charger and batteries all housed in an audio backbox enclosure.

For communication and annunciation there is a microphone for paging, a paging selector panel, firefighters' telephone and associated selector panels all housed in a central enclosure (CACF). The master paging and telephone modules are intended for installation in a CACF.

Note that the paging microphone and firefighters' telephone may be used together or independently, connected to a Flex-Net™ Network Central Alarm and Control Facility (CACF).

## Overall Features

- Large System Capacity and Modular Design.
- Provides peer-to-peer network communications
- Supports up to 63 nodes (including lobby panel).
- Supports copper and/or fiber optic network cable.
- Each Analog Loop is capable of supporting 159 AP Analog Sensors and 159 AP Addressable Modules (with a maximum of 99 CLIP sensors and 99 CLIP addressable modules) which can be wired as Class A (Style 6 or 7) or Class B (Style 4).
- 12 Ampere Power Supply.
- Four Class A/B (Style Z/Y) NACs rated at 1.7 Amperes each, which can be configured as Audible or Visual (silenceable or non-silenceable circuits). Audibles may be steady, Temporal Code, California Code, or March Time.
- Indicating circuits (NACs) may be configured to provide additional auxiliary power or resettable auxiliary power. NAC expansion using the INX-10A, INX-10ADS or INX-10AC.
- Fault isolators are present on all in-panel addressable loops.

- Configurable Signal Silence Inhibit, Auto Signal Silence, Two-Stage Operation, Assisted Walk Test.
- Outputs for 4 Wire resettable Smoke Power Supply, Auxiliary Power Supply, and an interface to the Mircom RTI-1 Remote Trouble Indicator.
- RS-485 Interface for Remote Annunciators. Remote Annunciators do not occupy a node on the network. Up to seven annunciators can be connected per node.
- Three Level Password Protection with field settable definition which enables the installer to determine what functions are accessible for each level of password
- Four Queues for Alarm, Supervisory, Trouble, and Monitor, with LED indicators and selector keys.
- Auxiliary Form-C Relay Contacts for Common Alarm, Common Supervisory, and Common Trouble.
- RS-232 Port for remote system printer or "CRT terminal".
- Two Event History Logs; one for Alarm related events and one for all events.
- Large 4 line by 20 character alphanumeric, back-lit LCD Display with user-friendly menu system.
- Common Controls and Indicators for System Reset, Lamp Test, Fire Drill, Signal Silence, General Alarm, Acknowledge, AC On, Pre-Alarm, and Ground Fault.
- Two Spare configurable switches and LED Indicators.
- 16 Zone configurable LED (bi-coloured) Annunciator with slide-in labels for Zone Description.
- Provides drift compensation for ionization and photoelectric smoke detectors
- Provides Signal Coding of signal circuits for easy alarm identification (code consists of 1 to 4 digits, each digit consisting of 1-15 pulses on the signal)
- Selection for Canadian (ULC) or USA (ULI) requirements for Smoke Sensor sensitivity.
- Extensive transient protection.
- Surface Mountable Enclosures with removable doors for easy installation and service. Flush Trims Available.
- Removable Terminal Blocks for easy wiring and service.
- Quad Loop Adder module ALCN-792M for expanding addressable loops by 2; with daughter board ALCN-792D expanding addressable loops by a total of 4.

### **Overall Audio Features:**

- Supervises signal circuits while in use.
- Control of fire management operations (e.g. all-call paging and total evacuation signalling).
- Indication of all required fault conditions.
- Microprocessor-based operations with hardware and software watchdog timer to ensure reliable system operation.
- Supervised tone generators.
- Up to 100 audio zones per node, 1575 audio amplifiers per Network system.
- Up to 5 (analog) firefighters' telephone zones per node and 315 (analog) telephone zones per Network system.
- 99 addressable telephone zones per loop, maximum of 29 addressable telephone loops per node, maximum of 144 addressable telephone zones per system.
- Easy configuration process.
- Operates from 24 VDC backup batteries in the event of a power failure.
- Removable terminal blocks for ease of installation and maintenance.
- Speaker circuits integrated with amplifier circuits.
- Maximum of 180 Watts per BBX-FXMNS.
- Maximum of 360 Watts per QBB-5001/R expansion cabinet and 1260 Watts of total power per BBX-FXMNS node with maximum expansion [180W +360W(3)=1260W].
- Optional redundant backup amplifier per node.

## Additional Features

---

Blackfin based Quad Loop Adder module ALCN-792M. The ALCN-792M is a 2 loop addressable adder module with provision to connect a daughter board ALCN-792D which contains an additional 2 addressable loops for a total of four addressable loops.

There are two additional main fire alarm panel displays:

DSPL-420 8 line LCD display narrow board

DSPL-2440 9 event, 24 line graphical display narrow board

The BBX-FXMNS enclosure is for the Integrated Fire and Audio consisting of a backbox, door and middle chassis. Part of this enclosure is the vertical mount telephone QMT-5302NV and the vertical mount paging microphone QMP-5101NV.

The ANC-5000 Audio Network Controller module includes ARCnet and an ethernet port. ARCnet reduces the wiring for audio and telephone to the ARCnet only or fiber optics (if used).

The QBC-5000N charger provides a dual voltage transformer for audio.

The RAXN-LCDG is a graphical display remote annunciator.

The Flex-Net™ is compatible with Coptir, Pinnacle, Acclimate and 4-20mA devices.

Configuration options are provided for grouping inputs.

Panel supports previous, current and next configuration. Configuration automatically reverts back to previous or moves to future configuration through front-panel menu.

**OPEN Graphic Navigator Software Package** allows 3D graphic display of premises and devices. Use the ethernet port on the main board to connect to OPEN graphics software.

Boolean logic functions are now available within the configuration software.

uBoot Based BootLoader program (inherent in the configuration) provides leading technology that allows a choice of multiple configuration files or firmware revisions to support site-specific requirements.

The FlexBoot™ shell offers UNIX style commands for directory listing, log download, diagnostic probing and system tuning and optimization.

## Document Conventions

---

### Circuits and Zones

The term **circuits** refers to an actual electrical interface, initiating (detection), indicating (signal), or relay.

The term **zone** is a logical concept for a fire alarm protected area, and will consist of at least one circuit.

Often the terms **zone** and **circuit** are used interchangeably, but in this manual the term circuit is used.

On the Flex-Net™, circuits can be hardwired inputs and outputs or addressable inputs and outputs. Both hardwired inputs and outputs, and addressable inputs and outputs may be grouped together to form logical zones.

### Wiring Styles

**Initiating circuits** are configured by default as Class B (Style B). They may be configured as Class A (Style D) as described in System *Configuration*. This operation uses odd and even pairs of two-wire Class B (Style B) circuits to make one four-wire Class A (Style D) circuit, thus cutting in half the number of available initiating circuits.

**Indicating circuits (NACs)** may be individually wired as Class A (Style Z) or Class B (Style Y) without affecting the number of circuits available.

Addressable Loops may be configured system wide as Class B (Style 4) or Class A (Style 6). With the addition of isolators, a Class A (Style 6) will become a Class A (Style 7).

# Typical Flex-Net™ Wiring Without Audio

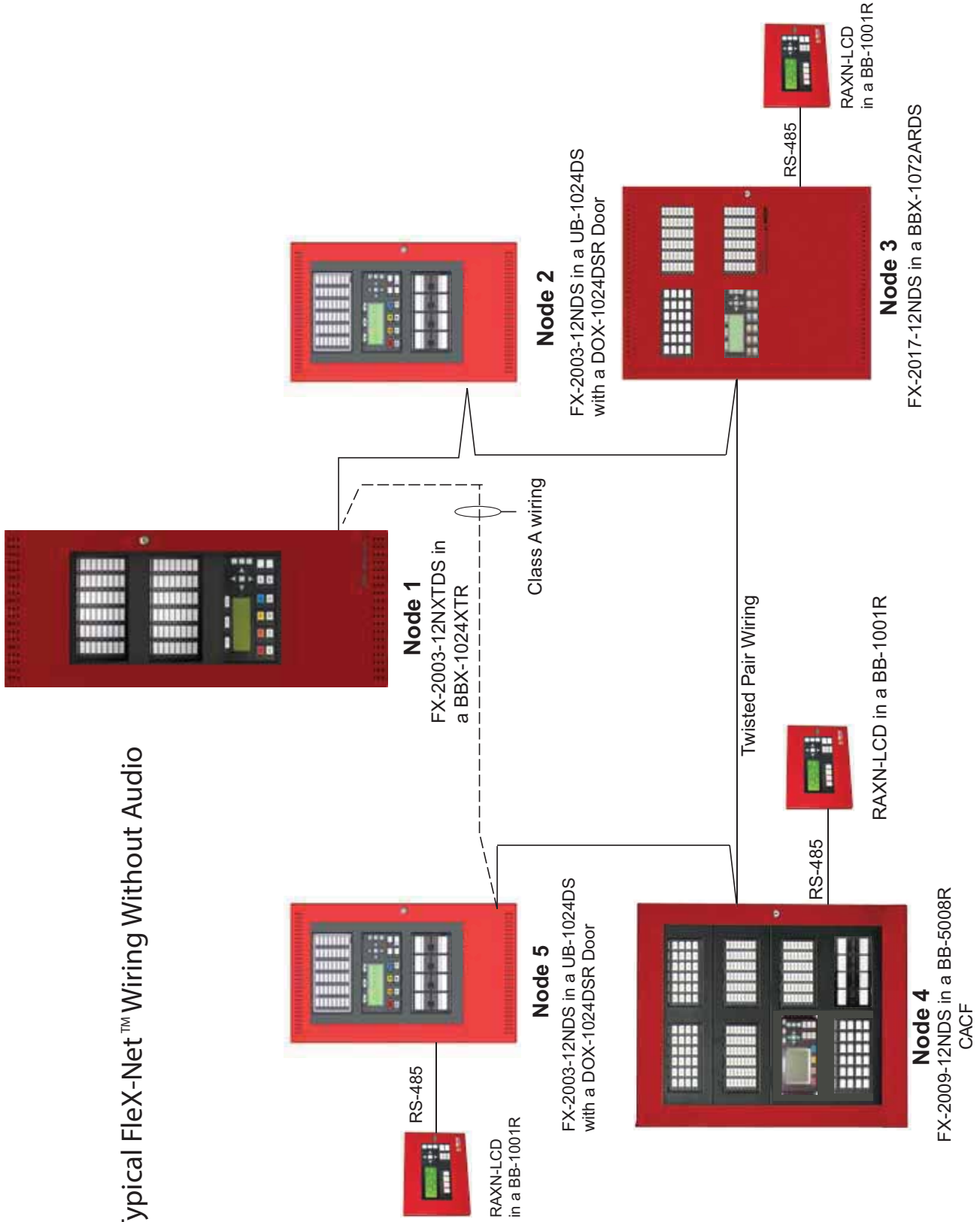



# Typical FleX-Net™ Wiring With Audio

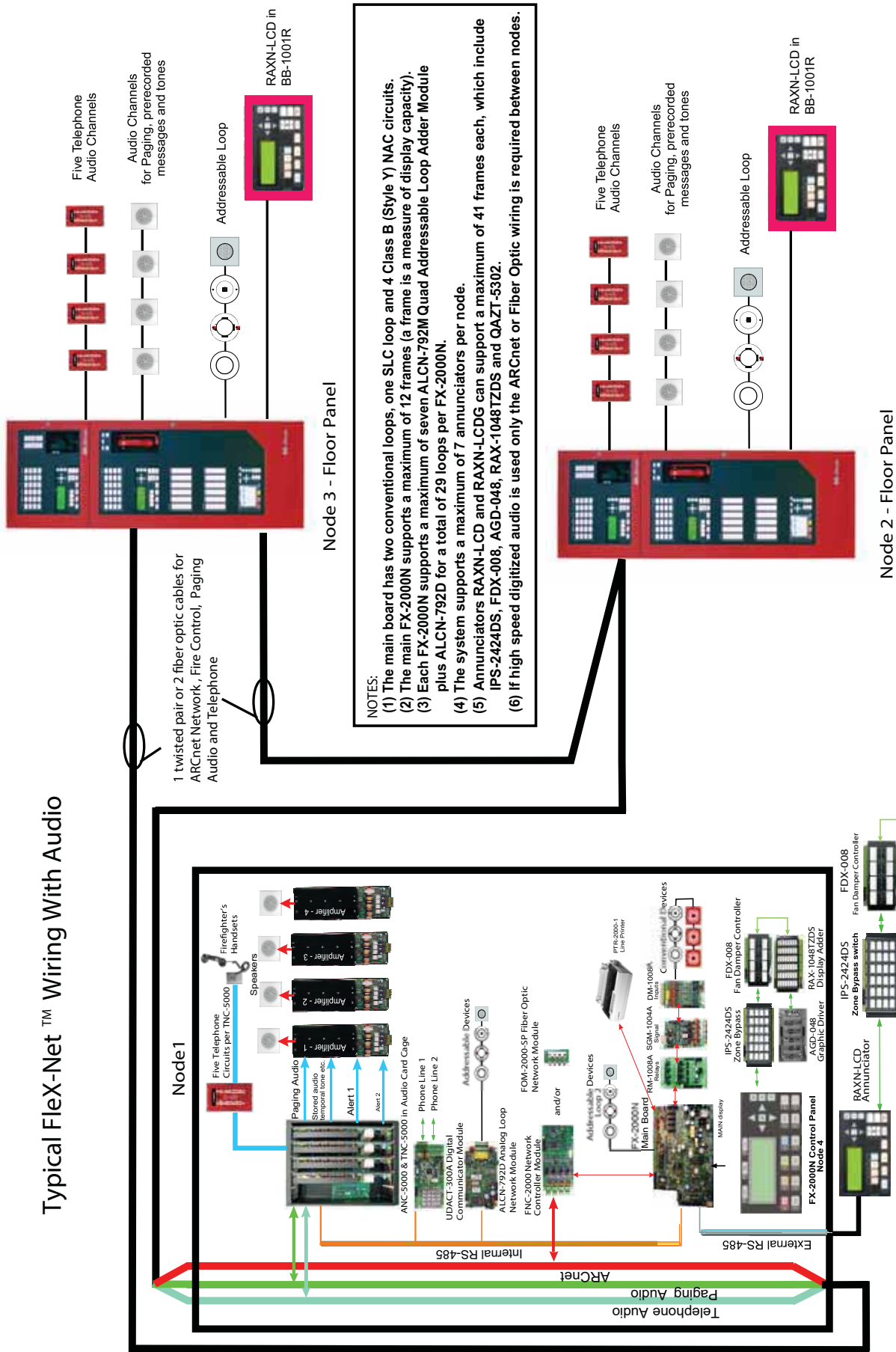







**NOTES:**

- (1) The main board has two conventional loops, one SLC loop and 4 Class B (Style Y) NAC circuits.
- (2) The main FX-2000N supports a maximum of 12 frames (a frame is a measure of display capacity).
- (3) Each FX-2000N supports a maximum of seven ALCN-792M Quad Addressable Loop Adder Module plus ALCN-792D for a total of 29 loops per FX-2000N.
- (4) The system supports a maximum of 7 annunciators per node.
- (5) Annunciators RAXN-LCD and RAXN-LCDG can support a maximum of 41 frames each, which include IPS-2424DS, FDX-008, AGD-048, RAX-1048TZDS and QAZT-5302.
- (6) If high speed digitized audio is used only the ARCnet or Fiber Optic wiring is required between nodes.



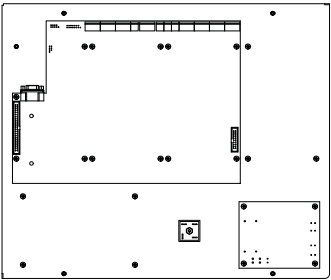

# System Components

## Chassis Types



|   | Model           | Description  |
|---|-----------------|--|
|    | FX-2003-12NDS   | <p><b>12 Amp Mid-Size Main Chassis.</b> This mid-size main chassis comes complete with one Analog Loop Controller (159 AP Analog Sensors and 159 AP Addressable Modules), 4 Class A/B (Style Z/Y) NACs (1.7 Amp each), a DSPL-420 4 line by 20 character LCD display and a 12 ampere power supply which charges 17-65 AH batteries. The FX-2003-12N supports the FNC-2000 Network Controller Module and 2 adder modules over the main board plus additional space in the chassis for 2 annunciator or programmable modules. This chassis mounts in the BBX-1024DS enclosure comprising a UB-1024DS black backbox and a door. A white door DOX-1024DS or DOX-1024DSR red door are available.</p> <p>This model does not support any network audio.</p>  |
|   | FX-2003-12NXTDS | <p><b>12 Amp Expanded Mid-Size Main Chassis.</b> This expanded mid-size main chassis comes complete with one Analog Loop Controller (159 AP Analog Sensors and 159 AP Addressable Modules), 4 Class A/B (Style Z/Y) NACs (1.7 Amp each), a DSPL-420 4 line by 20 character LCD display and a 12 ampere power supply which charges 17-65 AH batteries. The FX-2003-12NXTDS supports the FNC-2000 Network Controller Module and 2 adder modules over the main board plus additional space in the chassis for 6 adder boards and 2 annunciator or programmable modules. This chassis mounts in the BBX-1024DS enclosure comprising a UB-1024DS black backbox and a door. A white door DOX-1024DS or DOX-1024DSR red door are available.</p> <p>This model does not support any network audio.</p> |
|  | FX-2017-12NDS   | <p><b>12 Amp Mid-Size Main Chassis.</b> This mid-size main chassis comes complete with one Analog Loop Controller (159 AP Analog Sensors and 159 AP Addressable Modules), 4 Class A/B (Style Z/Y) NACs (1.7 Amp each), a DSPL-420 4 line by 20 character LCD display, and a 12 ampere power supply which charges 17-65 AH batteries. The FX-2017-12NDS supports the FNC-2000 Network Controller Module and 2 adder modules over the main board plus additional space in the chassis for 14 adder boards and 3 annunciator or programmable module. This chassis mounts in the BBX-1072ADS black backbox/white door or BBX-1072ARDS black backbox/red door.</p> <p>This model does not support any network audio.</p>  |





|  | Model                | Description  |
|--|----------------------|--|
|   | <p>FX-2009-12NDS</p> | <p><b>12 Amp Large Main Chassis.</b> This large main chassis comes complete with one Analog Loop Controller (159 AP Analog Sensors and 159 AP Addressable Modules), 4 Class A/B (Style Z/Y) NACs (1.7 Amp each), a DSPL-420 4 line by 20 character back-lit LCD display, and a 12 ampere power supply which charges 17-65 AH batteries. The FX-2009-12NDS supports the FNC-2000 Network Controller Module and 2 adder modules over the main board plus additional space in the chassis for 6 adder boards and 3 annunciator or programmable modules. This chassis mounts in the BB-5008 or BB-5014 black backbox/black door or BB-5008R black backbox/red door.</p> <p>This is model does not support any network audio.</p> |
|   | <p>FX-2000MNS</p>    | <p>Consists of a backplate which is mounted into the BBX-FXMNS backbox and a FX-2000N Fire Alarm Control board and a battery disconnect board.</p>   |
|  | <p>ECX-0012</p>      | <p>Expander Chassis to use with the FX-2009-12NDS. It provides space for 12 adder modules and two display modules. This chassis mounts into the BB-5008(R) or BB-5014 backbox.</p>   |

## Network Controller Modules



|   | Model       | Description   |
|---|-------------|---|
|    | FNC-2000    | Provides network capability for the FX-2000N Fire Alarm panel. One module is required per one network node panel. The FNC-2000 Fire Network Controller module is mounted in position 2 over the FX-2000N main board.  |
|    | ANC-5000    | Audio Network Controller module. The ANC-5000 Audio Network Controller module is mounted over a metal plate (which is packaged with the FX-2009-12N) and then the plate is mounted in a BB-5008 or BB-5014 backbox in positions marked 4 to 9 inclusive. The recommended plate mounting is sideways with LEDs across the top.                                     |
|    | TNC-5000    | Telephone Network Controller module. The TNC-5000 Telephone Network Controller module is mounted over the ANC-5000 Audio Network Controller module and both are mounted on a metal plate and then the plate is mounted in a BB-5008 or BB-5014 backbox in positions marked 4 to 9 inclusive. The recommended plate mounting is sideways with LEDs across the top. |
|  | FOM-2000-SP | <b>Fiber Optics Module (Optional)</b><br>Connects to the FNC-2000 Fire Alarm Network Controller Module and allows fiber optics cabling.   |



## Adder Modules

|   | Model     | Description                                  |
|---|-----------|--|
|  | ALCN-792M | Quad Loop Adder board.                       |
|  | ALCN-792D | Daughter board for ALCN-792M Quad Loop Adder |



|  | Model      | Description                           |
|--|------------|---------------------------------------|
|   | DM-1008A   | Eight Initiating Circuit Module       |
|   | SGM-1004A  | Four NAC circuit Module               |
|   | RM-1008A   | Eight Relay Circuit Module            |
|   | PR-300     | Polarity Reversal and City Tie Module |
|  | UDACT-300A | Digital Communicator/Dialer Module    |

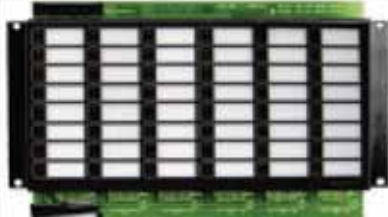

### Display Modules

|   | Model     | Description   |
|---|-----------|---|
|  | FDX-008   | Fan Damper Module   |
|  | DSPL-420  | 4 line by 20 character display which can be mounted into backboxes, BBX-1072ADS(ARDS), BB-5008(R), BB-5014 and the BBX-FXMNS Backbox. |
|  | DSPL-2440 | Graphic display which can be mounted in backboxes, BBX-1072ADS(ARDS), BB-5008(R), BB-5014 and the BBX-FXMNS Backbox                   |

|  | Model          | Description   |
|---|----------------|---|
|  | IPS-2424DS     | Programmable Input Switches Module (mounts with the FX-2009-12NDS and can also be part of the RAXN-LCD) |
|  | RAM-1032TZDS   | Model RAM-1032TZDS Main Chassis Remote Annunciator with 16 Bi-coloured LEDs and 32 trouble LEDs.        |
|   | RAX-1048TZTZDS | Model RAX-1048TZDS Adder Annunciator Chassis with 48 Bi-coloured LEDs and 48 trouble LEDs.              |

### Audio and Telephone Modules

|   | Model      | Description   |
|---|------------|---|
|  | QMP-5101N  | Network Master Paging Control Panel   |
|  | QMP-5101NV | Network Master Paging Control Panel (Vertical Mount) mounts within the BBX-FXMNS enclosure. |
|   | QMT-5302N  | Network Master Telephone Control Panel  |

|  | Model       | Description  |
|---|-------------|--|
|  | QMT-5302NV  | Network Master Telephone Control Panel (Vertical Mount) mounts within the BBX-FXMNS enclosure. |
|   | QAZT-5302DS | Zoned Paging and Telephone Selector Panel  |

### Booster Power Supply

|  | Model    | Description   |
|--|----------|---|
|  | INX-10AC | Addressable Booster Power Supply mounts to backboxes BB-5014 and BBX-FXMNS. Same unit as the INX-10A and INX-10ADS, except this model comes with a chassis for mounting. Refer to LT-899 manual for more detailed instructions. |





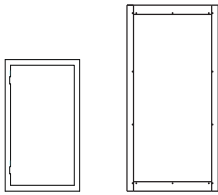

### Enclosures

|  | Model  | Description                       |
|---|--|-----------------------------------|
|   | BBX-1024DS white door black backbox (add suffix "R" for red door/black backbox)          | Enclosure 27.5"H x 16.5"W x 5.5"D |
|   | BBX-1072ADS white door black backbox (or BBX-1072ARDS for red door/black backbox)        | Enclosure 34"H x 26.5"W x 7.7"D   |
|   | BB-5008 black door and backbox (add suffix "R" for red door/black backbox)               | Backbox 36"H x 30"W x 7"D         |
|   | BB-5014 black door and backbox   | Backbox 60"H x 30"W x 7"D         |
|   | BBX-FXMNS Enclosure with white door assembly (add suffix "R" for red door/black backbox) | Backbox 61.5"H x 22"W x 9"D       |

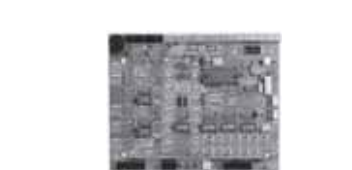

## Flush Trim Rings

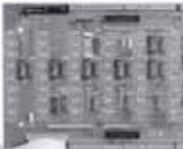
|  | Model     | Description   |
|---|-----------|---|
|   | FA-1072TR | Black flush trim ring for BBX-1072ADS and BBX-1072ARDS. |

## Remote Annunciators

|    | Model  | Description   |
|---|--|---|
|    | RAXN-LCD   | Remote Shared Display Annunciator. Please refer to LT-895 RAXN-LCD manual for further information.  |
|  | RAXN-LCDG  | Remote Shared Graphical Display Annunciator. Please refer to LT-6033 RAXN-LCDG manual for further information.  |
|  | RAM-1016<br>RAM-1016TZ<br>RAM-1016TZDS<br>(RA-1000 Series) | Model RAM-1016 Main Chassis Remote Annunciator with 16 Bi-coloured LEDs. Model RAM-1016TZDS Main Chassis Remote Annunciator with 16 Bi-coloured LEDs and 16 trouble LEDs. Please refer to LT-617 RA-1000 Series Annunciator manual for further information. |
|  | MGD-32   | Master Graphic Driver Annunciator Board   |
|  | AGD-048  | Adder Graphic Driver Board  |
|  | RAM-216  | Annunciator with 16 Bi-coloured LEDs.   |



|   |                |  |
|---|----------------|--|
|  | <p>RAM-208</p> | <p>Annunciator with 8 Bi-coloured LEDs.</p>                      |
|  | <p>RTI-1</p>   | <p>Remote Trouble Indicator (single LED and trouble buzzer).</p> |

### FX-LOC(R) Local Operating Console

|  | Model  | Description  |
|--|--|--|
|  | <p><b>FX-LOC(R) consists of:</b><br/>                 FX-LOC Enclosure includes backbox, inner door and outer white door.<br/>                 FX-LOC(R), the R suffix represents a red door.<br/>                 Main Display RAXN-LCD.<br/>                 Selection control panel FDS-008 plus IM-10A Ten Input Monitor module.<br/>                 Master paging microphone, model QMP-5101N.</p> | <p>The FX-LOC(R) Local Operating Console along with the Mircom FleX-Net™ Network Fire Alarm system facilitates a Mass Notification System. The FX-LOC(R) provides critical emergency (as well as fire) information to be communicated within buildings.<br/>                 Refer to LT-6039 FX-LOC(R) Installation Instruction Manual for further details and the LT-6042 Application Guide for Mass Notification information.</p> |

### Batteries

|  | Model   | Description        |
|---|---|--------------------|
|   | <p>BAT-12V18A<br/>                 BAT-12V26A<br/>                 BAT-12V33A<br/>                 BAT-12V42A<br/>                 BAT-12V55A</p> | <p>17 to 55 AH</p> |

### FleX-Net™ Accessories

| Model             | Description  |
|-------------------|--|
| <p>MP-300/R/S</p> | <p>End-of-line Resistor Plate, R for red, S for stainless steel finish</p> |
| <p>BC-160</p>     | <p>External Battery Cabinet (ULC and ULI listed)</p>                       |

# Mechanical Installation and Dimensions

Install the enclosure as shown for the BBX-1024DS installation information is in Figure 1. For the BBX-1072ADS see Figure 2, on the following page. Figure 3 demonstrates the BB-5008 backbox installation.

**Figure 1: .BX-1024DS Flush and Surface Enclosure Installation and Dimensions**

## BBX-1024DS BACKBOX AND DOOR

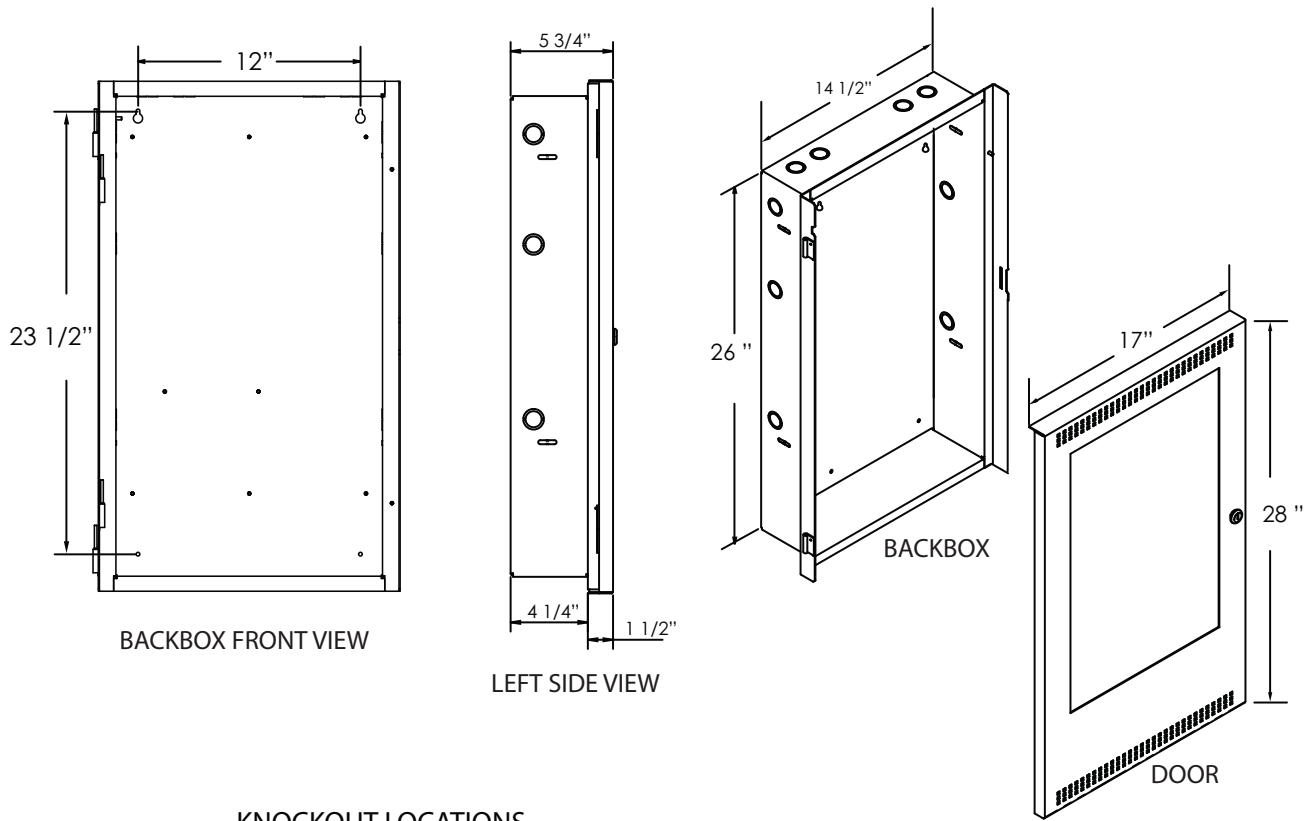

### KNOCKOUT LOCATIONS

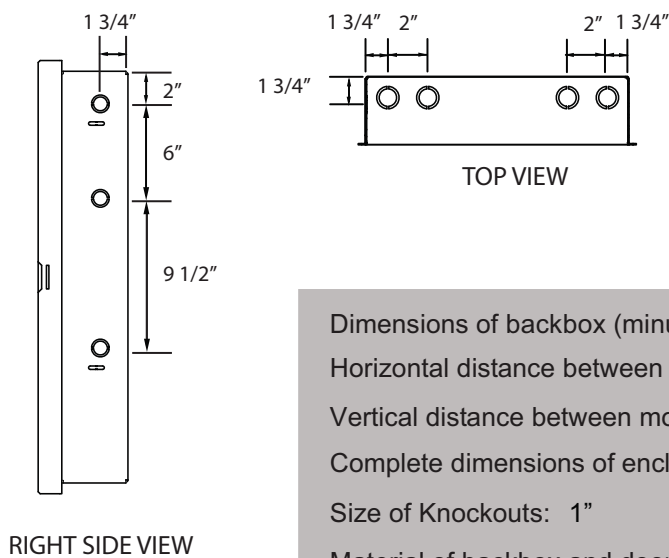

|  |  |
|--|--|
| Dimensions of backbox (minus built-in trim ring) | 26"H x 14 1/2"W x 4 1/4" D             |
| Horizontal distance between mounting screws      | 12"                                    |
| Vertical distance between mounting screws        | 23 1/2"                                |
| Complete dimensions of enclosure with door       | 28"H x 17"W x 5 3/4"D                  |
| Size of Knockouts:                               | 1"                                     |
| Material of backbox and door:                    | 16 GA (0.059") thick cold rolled steel |
| Finish of backbox and door:                      | Painted                                |

Figure 2: BBX-1072ADS Flush and Surface Installation and Dimensions

**Material:** Cold rolled steel, 16GA (0.059") thick for backbox, 14GA (0.075") thick for door  
**Finish:** Painted except for hinges

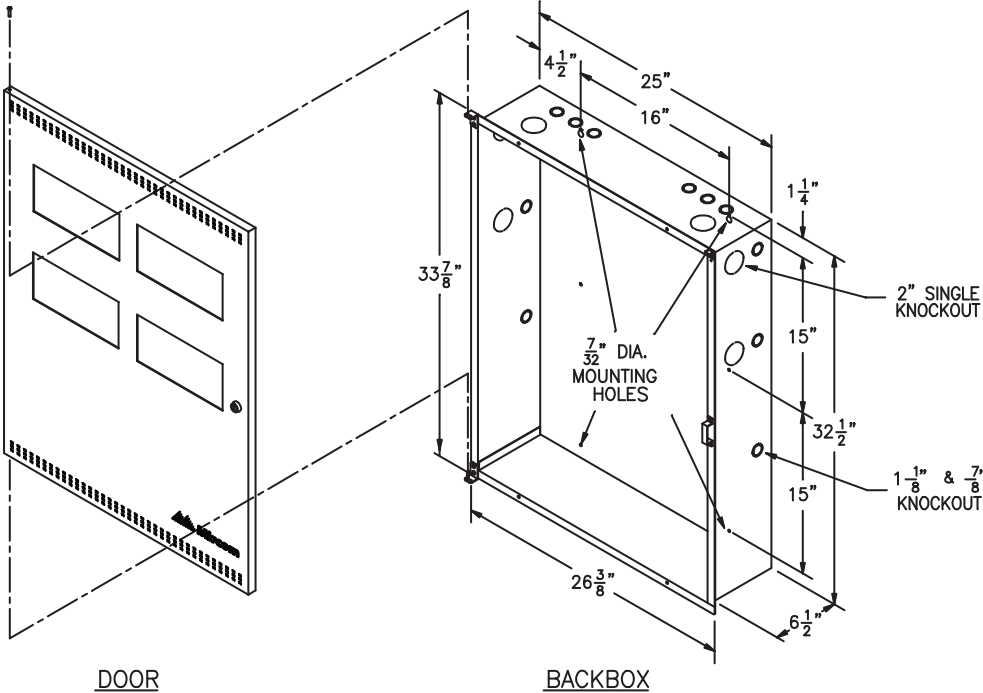
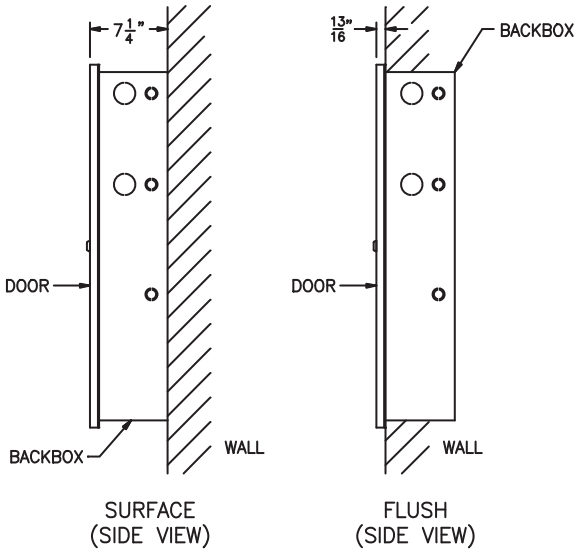

**Figure 3: BB-5008 Enclosure Installation Instructions and Dimensions**

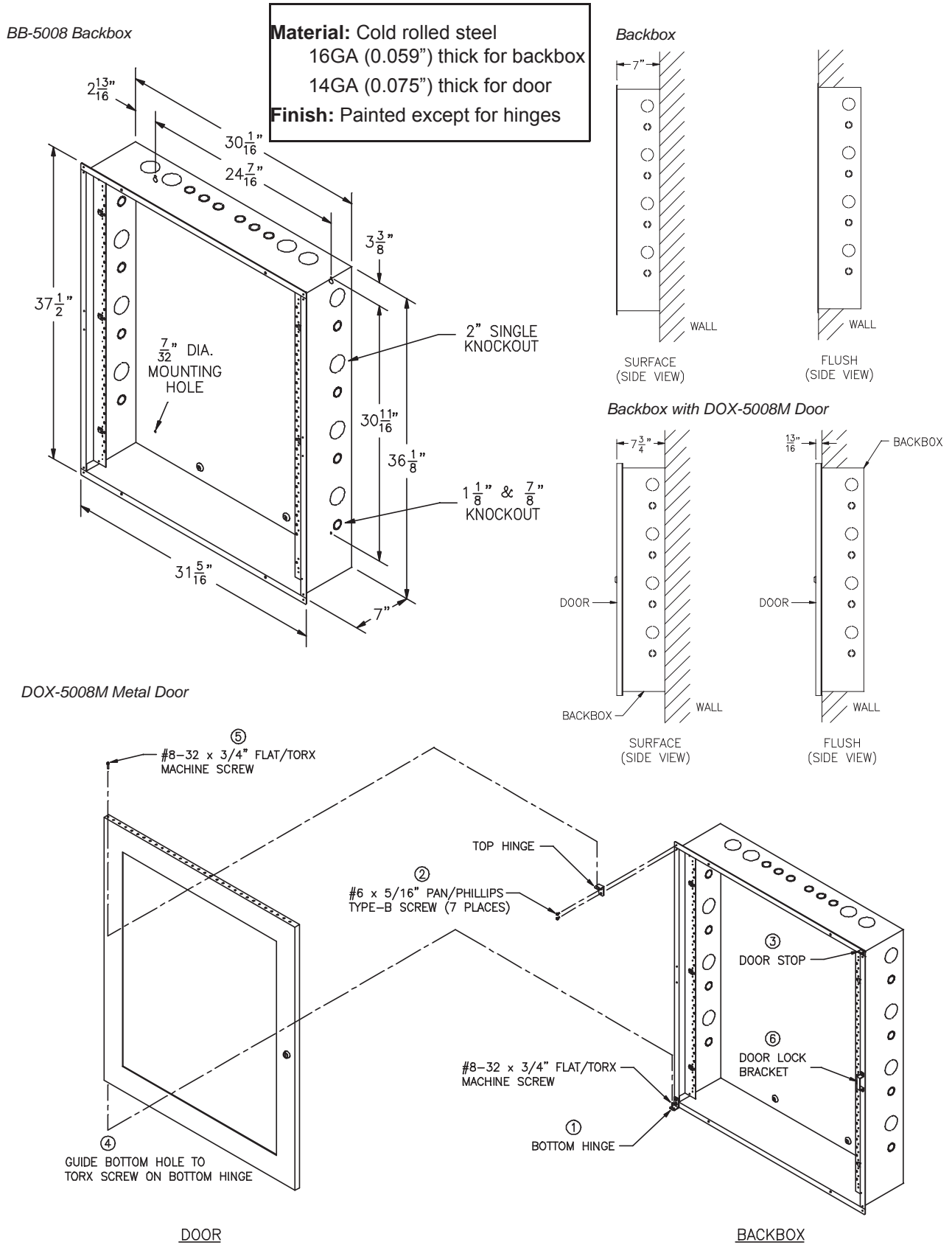

# BBX-1024XT/R Mechanical Installation

The model FX-2003-12NXTDS is an expanded version of the FX-2003-12NDS chassis. The FX-2003-12NXTDS mounts into the BBX-1024XT(white enclosure) and the BBX-1024XTR(red enclosure)

|                          |                                    |
|--------------------------|------------------------------------|
| <b>Dimensions</b>        | 14.76" wide by 35.8" long by 5.45" |
| <b>Cold Rolled Steel</b> | 16GA (0.059") thick for backbox    |
| <b>Cold Rolled Steel</b> | 14GA (0.075") thick for door       |
| <b>Finish</b>            | Painted except for hinges          |

**Figure 4: BBX-1024XT/R Backbox Enclosure with Trim Ring**

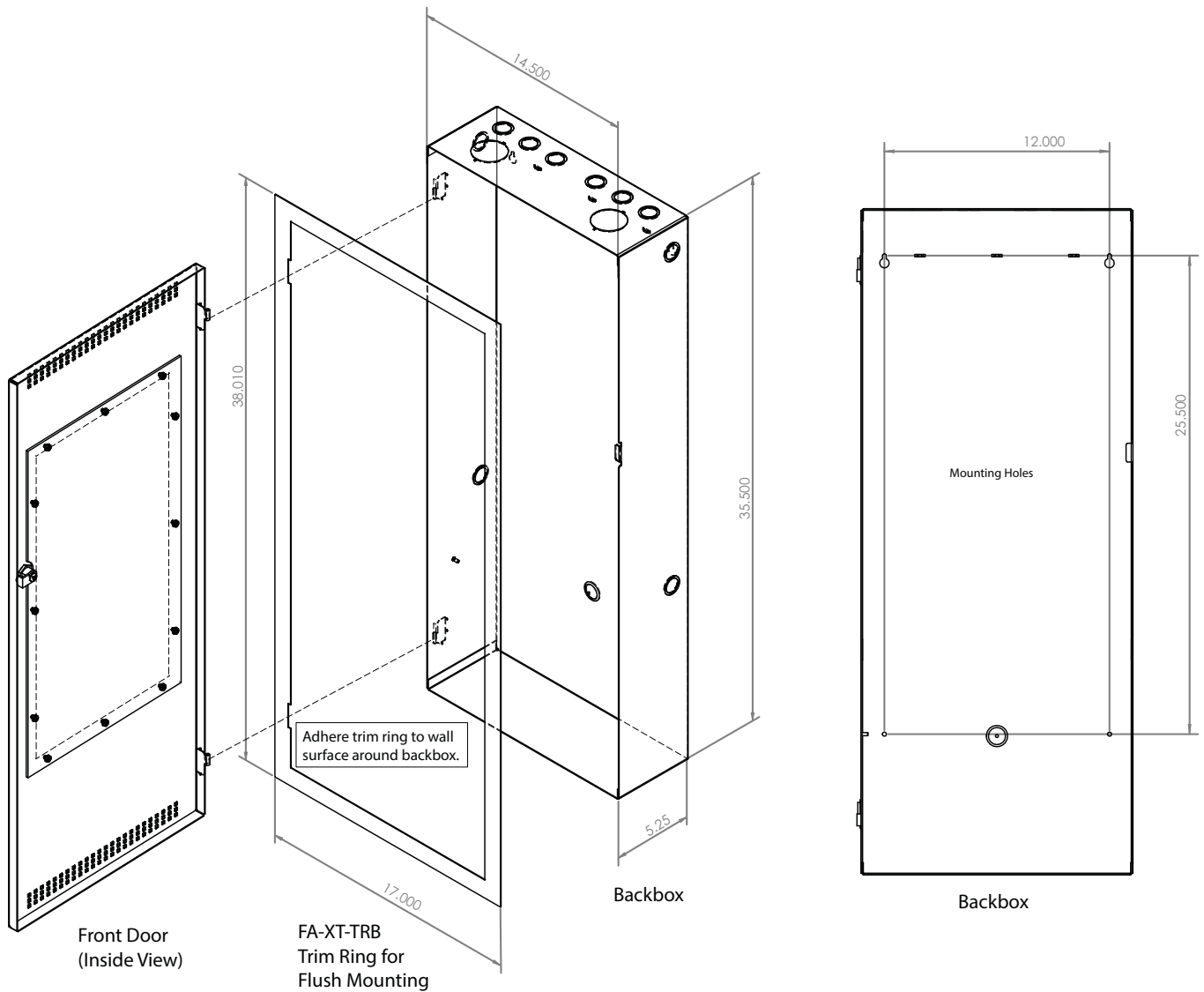

## General Chassis Installation

1. Group the incoming wires through the top of the enclosure to prepare it for wiring the modules. Do not run the wires in-between the modules since it could cause a short circuit.
2. Use a wire tie to group wires for easy identification and neatness.
3. Be sure to connect a solid earth ground (from building system ground / to a cold water pipe) to the chassis earth ground mounting lug, and to connect the earth ground wire lugs from the main chassis to the ground screw on the backbox.

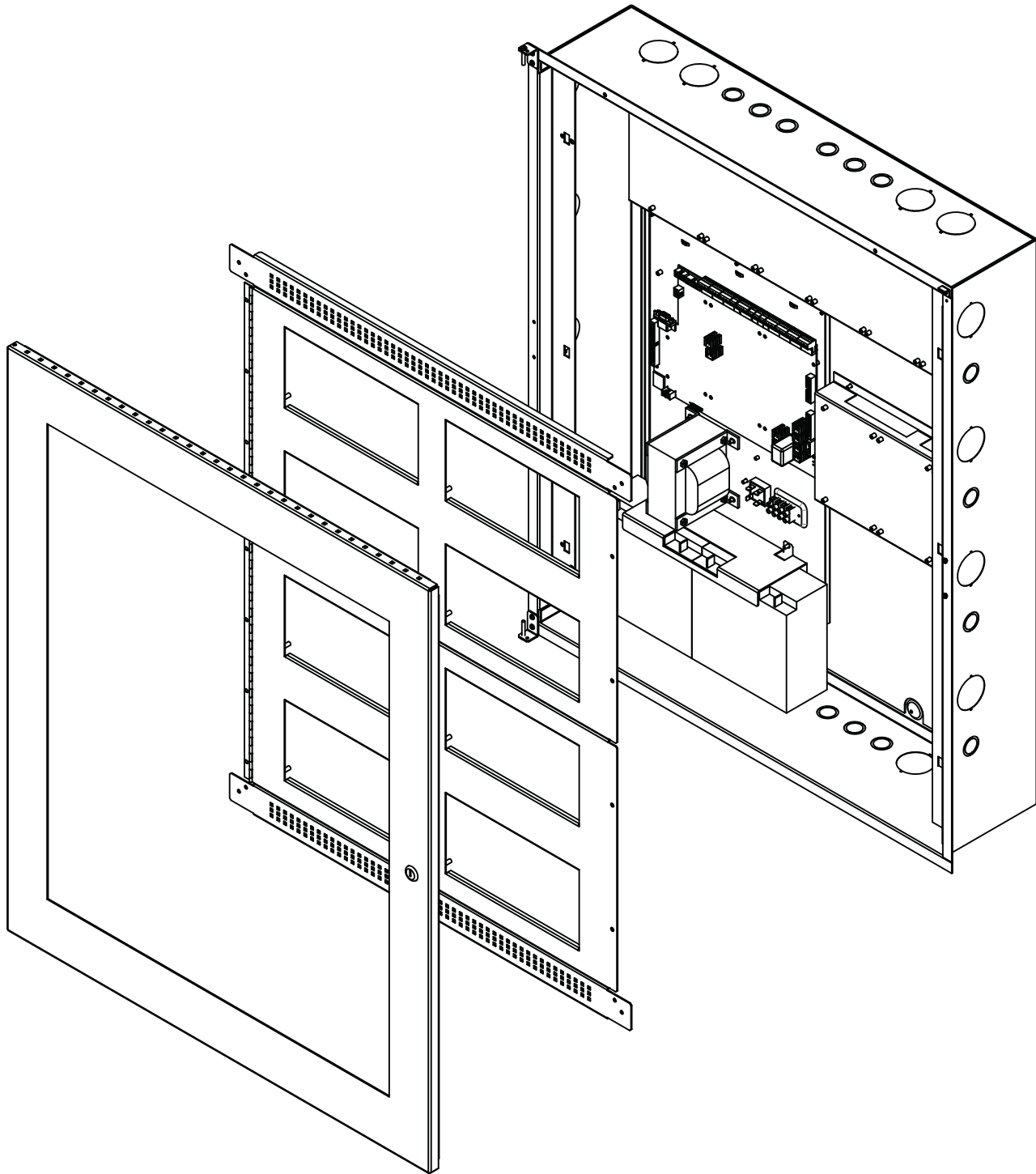

**Figure 5: Installation Instructions and Dimensions for BB-5014**

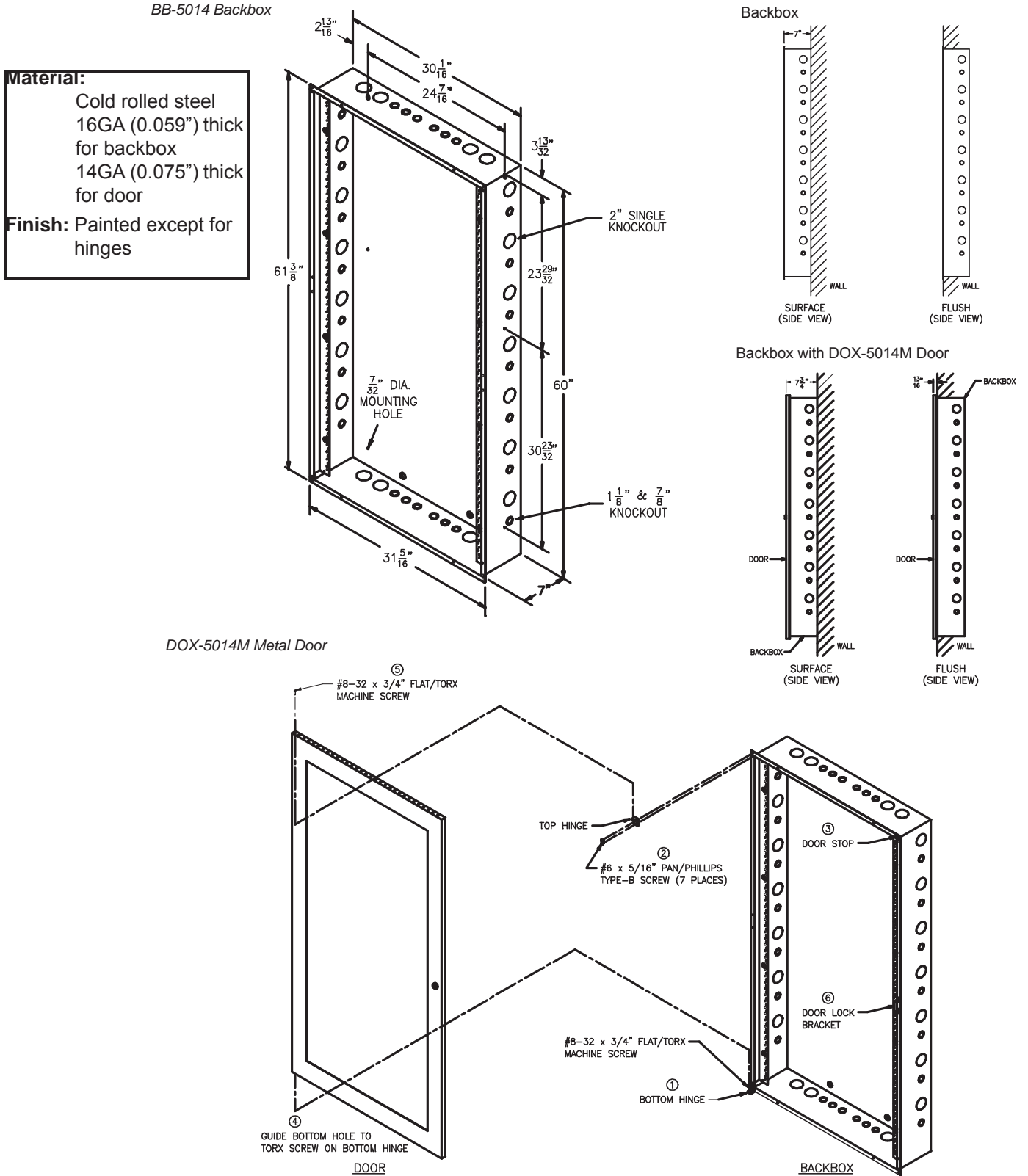

**Note:** Mount the power supply in the same manner as shown in Figure 3.

# Module Mounting Locations

The FX-2003-12NDS or FX-2017-12NDS Main Chassis come pre-assembled with a main fire alarm board, display components and boards. Install the adder modules of different types as shown in the diagrams on the following pages.



**Notes:** For many adder modules to enable communication from the main module to all of the adder modules, it is necessary to add a continuity jumper on the last adder module in a chain (see the appropriate module settings section to verify the location of the continuity jumper on a particular circuit adder module). Only the last circuit adder module should have a jumper plug on its continuity jumper; all others must be left without a jumper plug.

**Figure 6: Module Mounting Locations View #1**

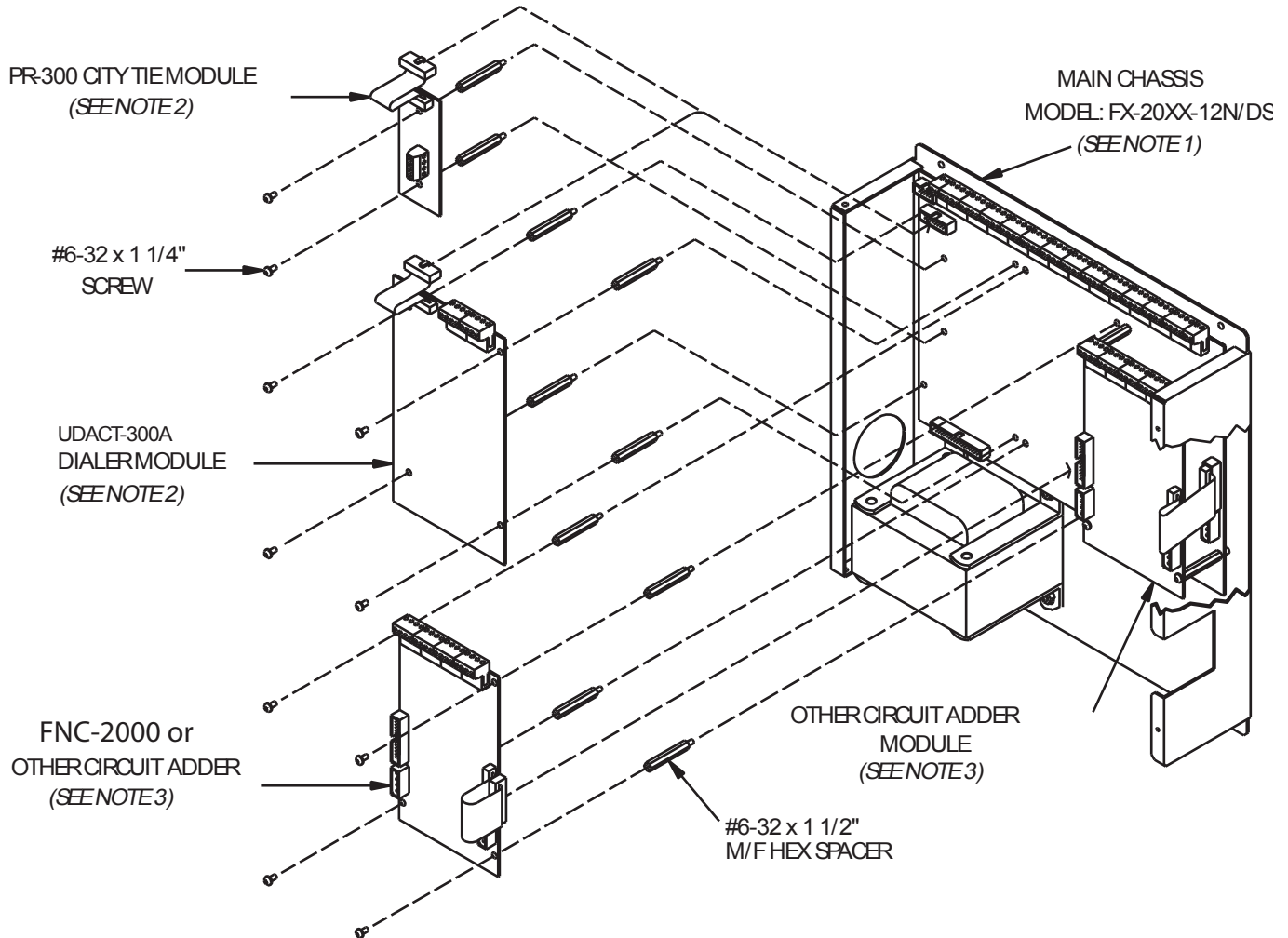

**Notes:**

1. Front plate is not shown.
2. Position reserved for PR-300 or UDACT-300A.
3. Other circuit adder modules may include:
  - FNC-2000
  - DM-1008A Detection Circuit Adder Module
  - SGM-1004A Signal Circuit Adder Module
  - RM-1008A Relay Circuit Adder Module
  - ALCN-792M and ALCN-792D Loop Adder Modules



**Figure 7: Module Mounting Locations View #2**

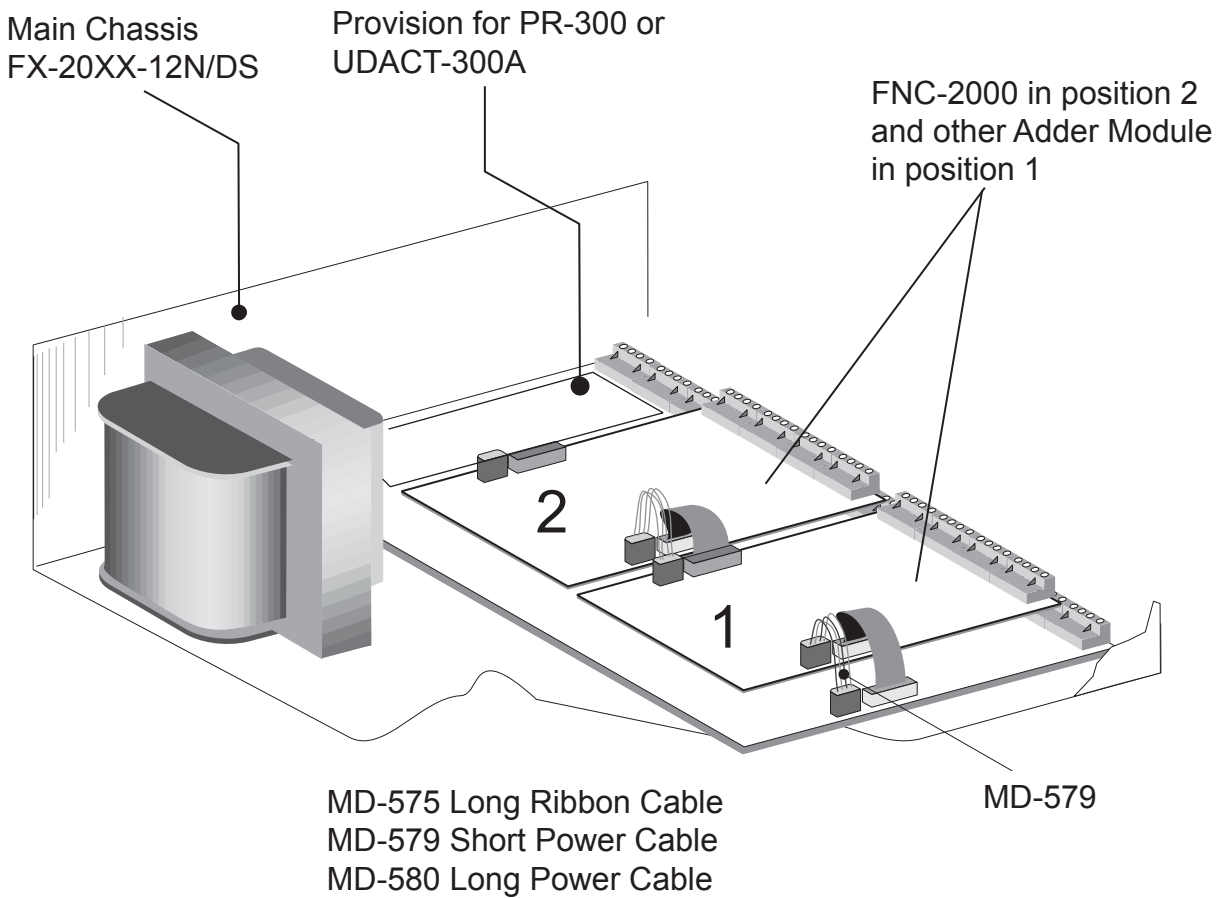

### FNC-2000 Fire Network Controller Module

This module is required in the main lobby and one per node. It mounts over the main fire alarm board, preferably in position 2. Use the four 2" spacers and four screws to secure the FNC-2000 to the main fire alarm board.

# Display and Adder Modules Mounting Locations

## FX-2003-12NDS Compact Main Chassis

Mounts in the BBX-1024DS Enclosure and supports three adder modules.

Interior View



Inside Backbox View

Slot 3 is reserved for PR-300 or UDACT-300A. If not required, this slot can be used to mount any of the adder modules.

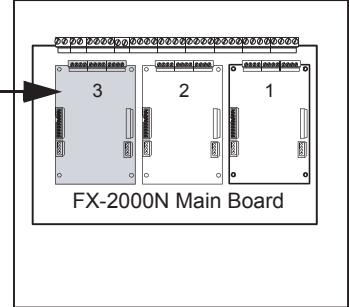

The recommended mounting position is 2 for the FNC-2000. The FOM-2000-SP board, if used, is mounted over the FNC-2000 board.

## FX-2003-12NXTDS Mid-size Main Chassis

Mount into the BBX-1024XT enclosure, and supports two display modules and

Interior View



Inside Backbox View

Slot is reserved for FNC-2000. If not required, this slot can be used to mount any of the adder modules.

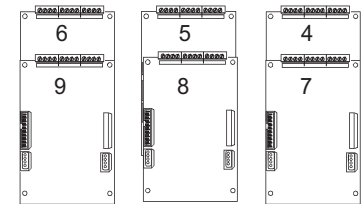

Slot is reserved for PR-300 or UDACT-300A. If not required, this slot can be used to mount any of the adder modules.

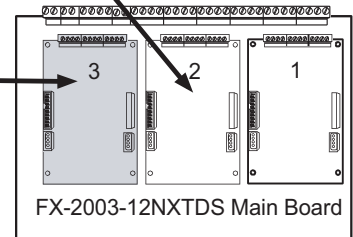

### FX-2017-12NDS Mid-size Main Chassis

Mounts in the BBX-1072ADS/ARDS Enclosure, and supports three display modules and 17 adder modules.

**Interior View**

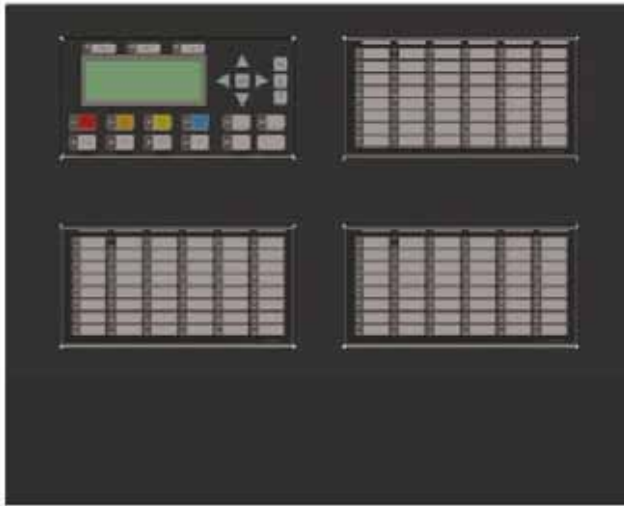

**Inside Backbox View**

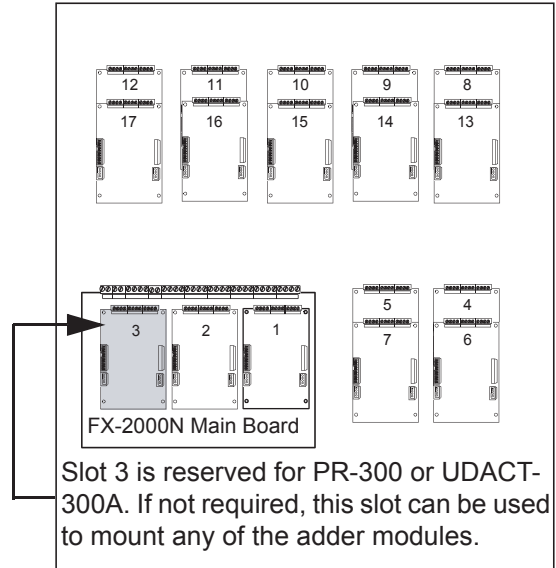

The recommended mounting position is 2 for the FNC-2000. The FOM-2000-SP board, if used, is mounted over the FNC-2000 board.

### FX-2009-12NDS Large Main Chassis

Mounts and occupies four display positions in BB-5008 or BB-5014 Enclosures, and supports two display modules and nine adder modules. This large chassis size can hold the integrated audio and/or telephone modules.

**Interior View**



**Inside Backbox View**

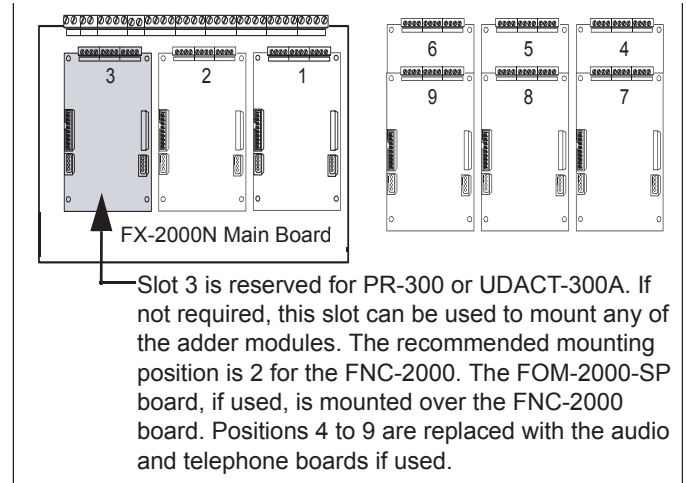

## ECX-0012 Expander Chassis for FX-2009-12NDS

Mounts and occupies two display positions in BB-5008 or BB-5014 Enclosures, and supports two display and 12 adder modules.

**Interior View**

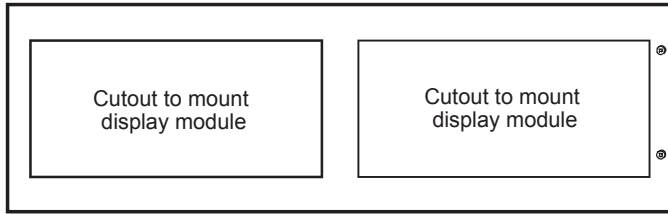

**Inside Backbox View**

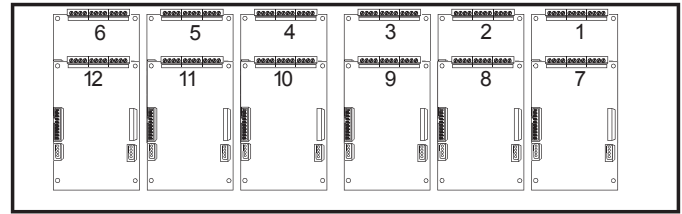

### NETWORK CONTROLLER MODULES

The FNC-2000 Fire Network Controller module is mounted in position 2 over the FX-2000N main board. The TNC-5000 Telephone Network Controller module is mounted over the ANC-5000 Audio Network Controller module and both are mounted on a metal plate and that plate is mounted in a BB-5008 or BB-5014 backbox in positions marked 4 to 9 inclusive, refer to previous drawing of large chassis.



**FNC-2000**  
Fire Network Controller Module



**ANC-5000**  
Audio Network Controller Module



**TNC-5000**  
Telephone Network Controller Module



**FOM-2000-SP**  
Fiber Optics Module  
Mounts over the FNC-2000 Fire Network Controller Module

### Adder Modules

Each adder module occupies one module slot and mounts inside the following chassis:

- FX-2003-12NDS Compact Main Chassis
- FX-2003-12NXTDS Mid-size Main Chassis
- FX-2017-12NDS Mid-size Main Chassis
- FX-2009-12NDS Large Main Chassis and ECX-0012 Expander Chassis for FX-2009-12NDS



**ALCN-792M**  
Quad Intelligent Analog Loop Adder Module.



**DM-1008A**  
Eight Initiating Circuit Module



**SGM-1004A**  
Four NAC circuit Module



**RM-1008A**  
Eight Relay Circuit Module



**ALCN-792D**  
Daughter Board Analog 2 Loop Adder Module.



**UDACT-300A**  
Digital Alarm Communicator Module



**PR-300**  
Polarity Reversal/ City Tie Module

Mounts over ALCN-792M

## Display Modules

Each display module occupies one display position and mounts to the display cutouts on the following chassis:

- FX-2003-12NDS Compact Main Chassis
- FX-2003-12NXTDS Mid-size Main Chassis
- FX-2017-12NDS Mid-size Main Chassis
- FX-2009-12NDS Large Main Chassis
- ECX-0012 Expander Chassis for FX-2009-12NDS

These modules can also be mounted in the standard BB-5000 Series enclosures which have cutouts (with brackets), and the BBX-1000 Series enclosures (requires RAXN-LCD as a driver) “Frame” is a measure of display capacity, used in the programming of the system.

### DSPL-420

Narrow Display Control(3 Frames)



### RAM-1032TZDS

Programmable Zone LED Annunciator Module (3 Frames)



### IPS-2424DS

Programmable Input Switches Module (2 Frames)



### DSPL-2440

Graphic Display Control(3 Frames)



### RAX-1048TZDS

Programmable Zone/Trouble LED Annunciator Module (3 Frames)

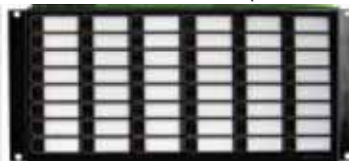

### FDX-008/KI

Fan Damper Module (1 Frame)



# Module Settings

## Main Fire Alarm Module (MD-871A "N" Version Main Chassis)

This main board has one addressable loop and network capability.

- JW1** Jumper is removed if a PR-300 or UDACT-300A is installed.
- JW2,JW4** Jumpers are Factory Set and should not be changed.
- JW5** Normally un-installed, add jumper to silence on-board buzzer.
- JW6** Normally installed, remove jumper to enable external power supply supervision.
- P1,2** Factory connection to Bridge Rectifier.
- P3** Black RS-485 Connector connects to the Adder Loop ALCN-792M if used (Address Loops 3 and 4)
- P4** Connector for PR-300 Module or UDACT-300A.
- P5** Connector for next 8 Conventional Hardwire Circuit Adder Modules (Loop 1).
- P6** Connector for first 8 Conventional Hardwire Circuit Adder Modules (Loop 0).
- P7** Ethernet jack.
- P8** Power Connector for Adder Modules.
- P9** RS-232C for Printer or "CRT" Monitor.
- P10,11** Connection to 24 VDC Battery. Observe Polarity.
- P14** Connector for Display Module.
- P15, J1** Connectors for Factory Use.
- P16** High speed RS-485 audio link to ANC-5000 Audio Network Controller Module. When connected provides ARCnet or Fiber Optic audio and telephone communication
- P19** Connector for FNC-2000 Fire Network Controller Module.
- SW2** DIP Switch for node address.
- NAC PWR** **24V FWR** input terminals for additional power for signal adder modules.
- F1** 20 Amp slow blow non-replaceable fuse.



**Note:** To enable communication from the Main Module to all of the Adder Modules, it is necessary to add a Continuity Jumper on the last Adder Module in a chain (see the appropriate Module Settings section to verify the location of the Continuity Jumper on a particular Circuit Adder Module). Only the last circuit adder module should have a jumper plug on its continuity jumper; all others must be left without a jumper plug.

**TO CONFIGURE THE FIRE ALARM PANEL USE THE RS-485 CONNECTOR P4 OF THE LAST ADDER LOOP CONTROLLER MODULE INSTALLED OR IF NOT PRESENT, P3 ON THE Flex-Net™ MAIN FIRE ALARM MODULE.**

**Figure 8: Main Fire Alarm Module (MD-871A "N" Version Main Chassis)**

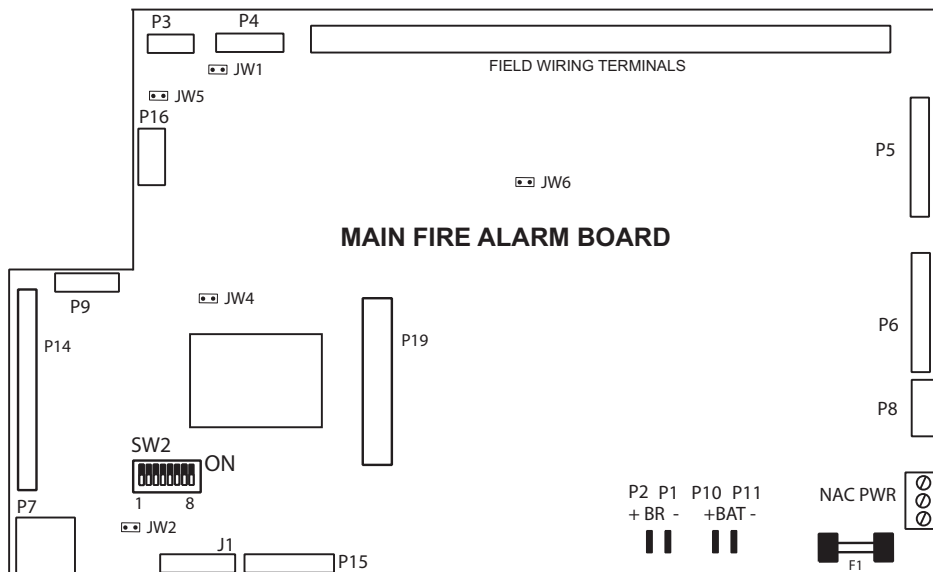

## SW2 DIP Switch Node Address Setting on Main Fire Alarm Module

Refer to table in Appendix C: DIP Switch Settings for Node Address Setting. Available addresses are 1 to 63. DIP Switch SW2-1 is the least significant digit.

## DSPL-420 Main Display Module

The DSPL-420 mounts into backboxes BB-5008(R), BB-5014(R) and BBX-FXMNS. This display is part of the following main fire alarm chassis: FX-2003-12NDS, FX-2003-12XTDS, FX-2009-12NDS, FX-2017-NDS, and FX-2000MNS.

**Figure 9: DSPL-420 Main Display Module (Part of Main Chassis c/w Main Fire Alarm Module)**

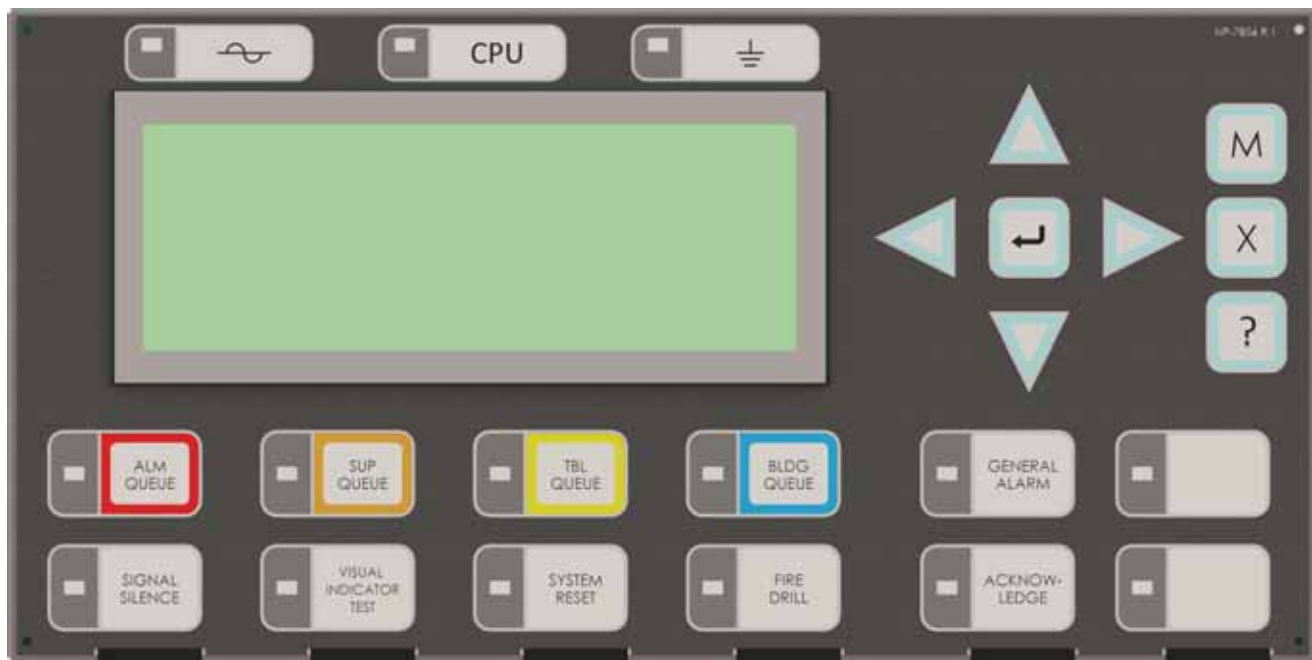

**P1:** Cable connects to P14 of the FX-2000N main fire alarm board (Figure 8).

**P2:** Connection to P1 of any adder display module if used.



**Note:** The main display module comes with slide-in paper labels including both English and French slide-ins, and laser printer-compatible blanks for zone labelling.

## DSPL-2440 Graphical Main Display Module

The DSPL-2440 is a separate item. It can be mounted into backboxes BB-5008(R), BB-5014(R) and BBX-FXMNS. It can replace the DSPL-420 found with the following models: FX-2003-12NDS, FX-2003-12XTDS, FX-2009-12NDS, FX-2017-NDS, and FX-2000MNS.

Figure 10: DSPL-2440 Graphical Main Display Module

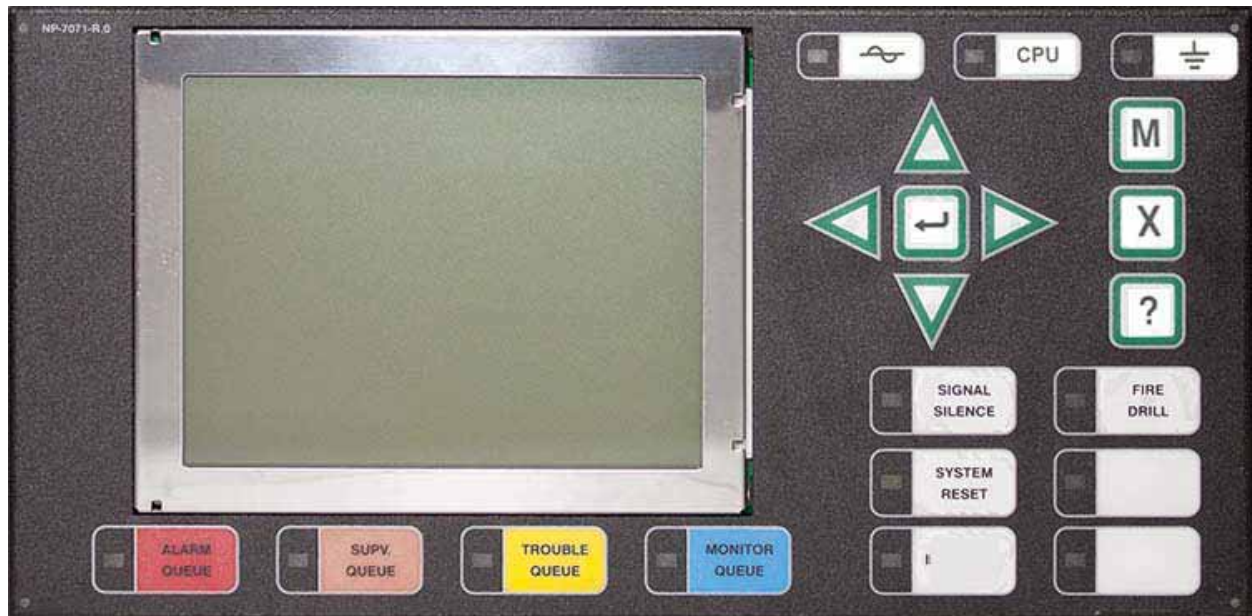

**P1:** Cable connects to P14 of the FX-2000N main fire alarm board (Figure 8).

**P2:** Connection to P1 of any adder display module if used.



**Note:** The main display module comes with slide-in paper labels including both English and French slide-ins, and laser printer-compatible blanks for zone labelling.



### FNC-2000 Fire Network Controller Module

An FNC-2000 Fire Network Controller module is required in each fire alarm node in the system. The FNC-2000 also provides a connection for an optional FOM-2000-SP Fiber Optics Module.

**Figure 11: FNC-2000 Fire Network Controller Module**

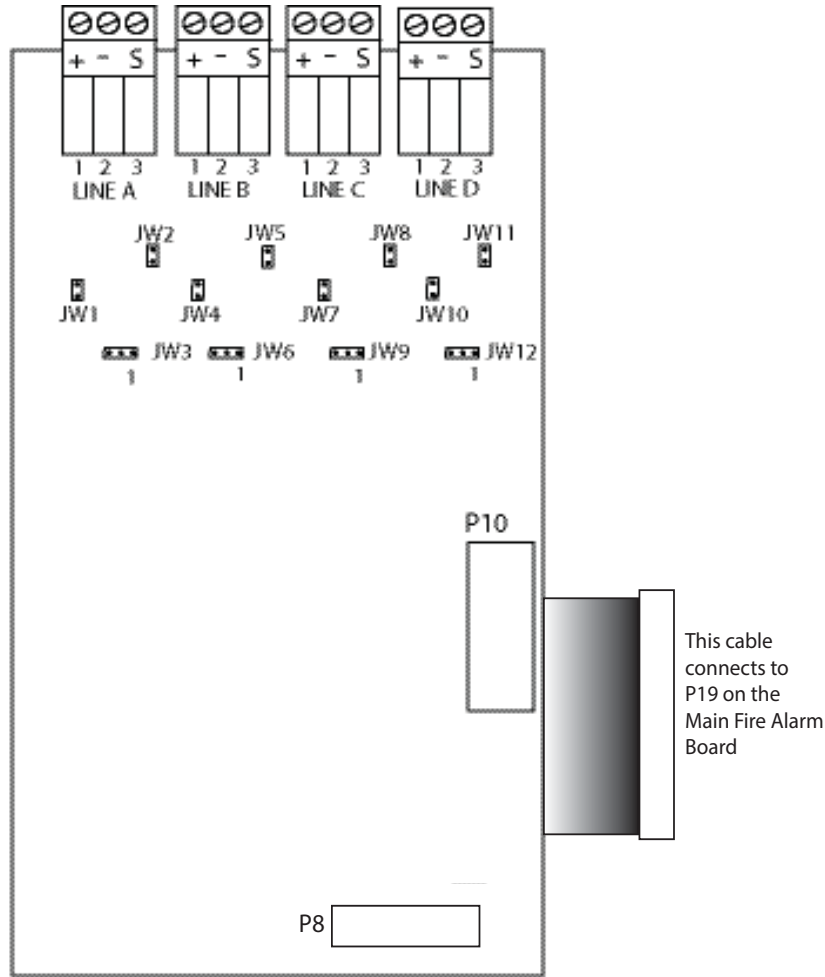

**Table 1: FNC-2000 Module List of Connectors and Jumpers and Functions**

| CONNECTOR OR JUMPERS                 | Function   |
|--------------------------------------|--|
| <b>P8</b>                            | <b>P8</b> is for Factory Use Only.   |
| <b>P10</b>                           | <b>P10</b> connects to <b>P1</b> of the FOM-2000-SP Fiber Optic Network Adder Module if used.  |
| <b>JW1, JW2, JW4, JW7, JW8, JW11</b> | Jumpers for <b>JW1, JW4, JW7, and JW10</b> equal Line Termination (always short).<br>Jumpers for <b>JW2 and JW8</b> equal Ground Fault (always short). |
| <b>JW5 and JW11</b>                  | Leave both un-installed. Do not connect JW5 or JW11 (open)   |
| <b>JW3, JW6, JW9, JW12</b>           | Jumpers for <b>JW3, JW6, JW9, JW12</b> shall be present between pins 1 and 2 (far right) and remain as is.   |



**Note:** Network connection is through twisted cable from Line A, B, C and D. Refer to Figure 33 for specific wiring and cable information.

**Figure 12: FOM-2000-SP Fiber Optic Network Module**

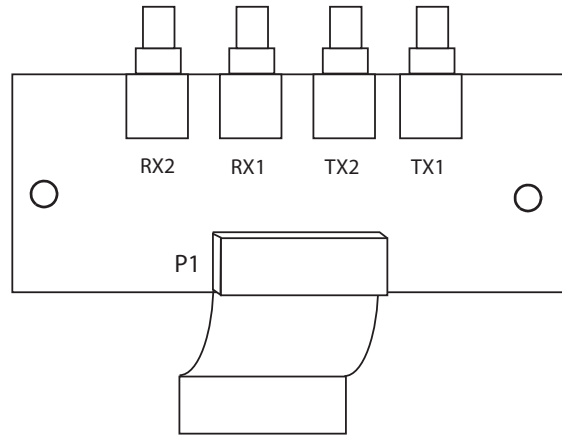

One of these modules is required at each panel where fiber optics will be used between them. The FOM-2000-SP will be mounted over the FNC-2000 Network board (over the field wiring terminals) with two #6 Phillips screws and two Hex spacers.

**Table 2: FOM-2000-SP Fiber Optic Network Module Cable Connection**

| Connector | Function   |
|-----------|--|
| P1        | P1 cable attaches to P10 of the FNC-2000 Fire Network Controller Module. |

**RAX-1048TZDS Zone Display Module**

**Figure 13: Zone Display Module (RAX-1048TZDS)**

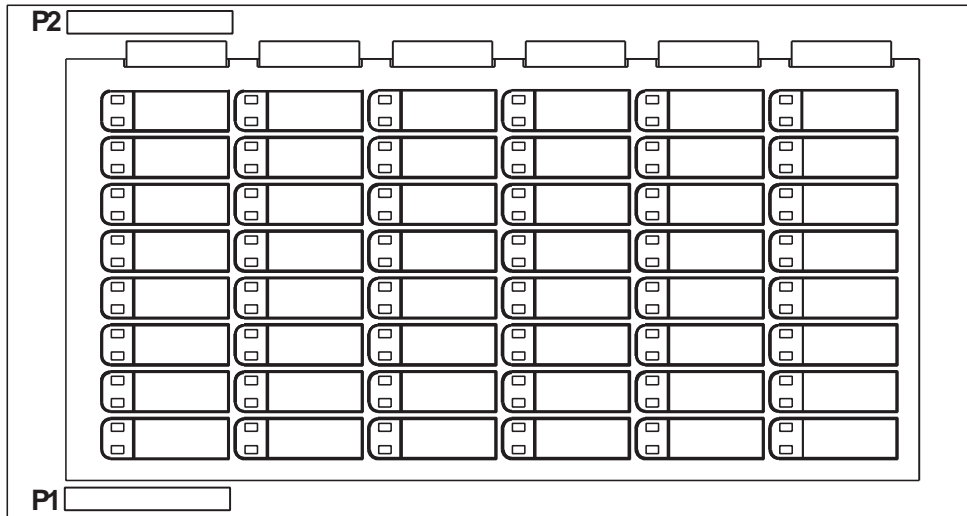

**Table 3: RAX-1048TZDS Zone Display Module Cable Function**

| Connector | Function  |
|-----------|---|
| P1        | P1 Cable connects to P2 of previous display module. |
| P2        | P2 Cable connects to P1 of next display module      |



**Note:** The zone display module comes with laser printer-compatible slide-in paper labels for zone labelling.

Figure 14: IPS-2424DS Programmable Input Switches Module

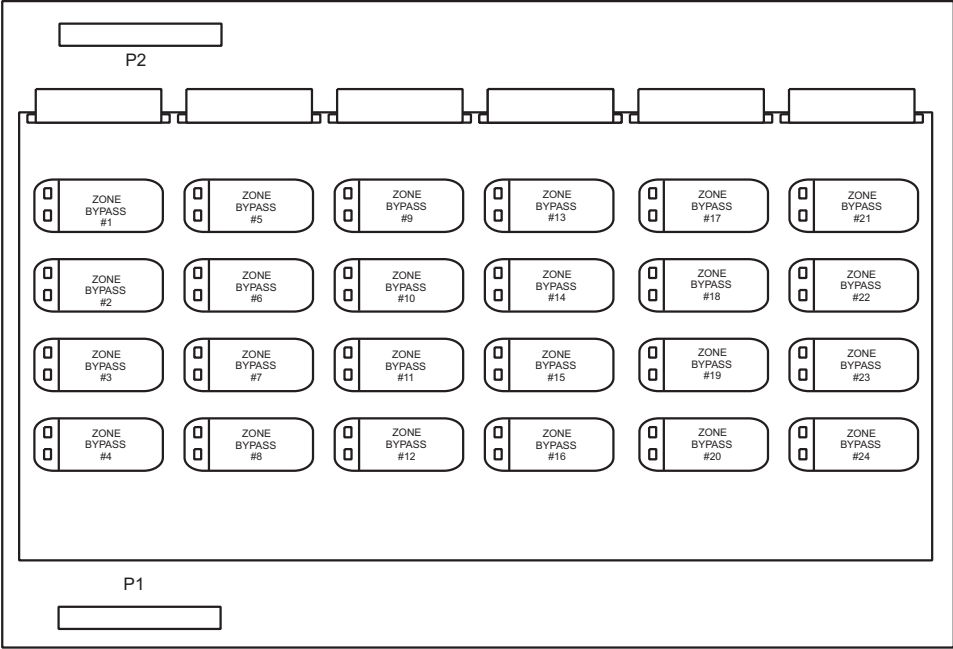

Table 4: IPS-2424DS Programmable Input Switches Module Cable Function

| Connector | Function  |
|-----------|---|
| P1        | P1 Cable connects to P2 of previous display module. |
| P2        | P2 Cable connects to P1 of next display module      |



Note: The IPS-2424DS module comes with laser printer-compatible slide-in paper labels for zone labelling.

### Figure 15: Fan Damper Control Display Module (FDX-008/KI)

There are two models of the Fan Damper Control Display modules available. The FDX-008 provides switch control and LED indication of 8 fan damper zones. The FDX-008KI provides switch control of 7 fan damper zones with the eighth zone activated by keyswitch. LED indication is provided for all 8 fan damper zones on the FDX-008KI. Both the FDX-008 and the FDX-008KI are used in conjunction with an FX-2000N Fire Alarm Control Panel.

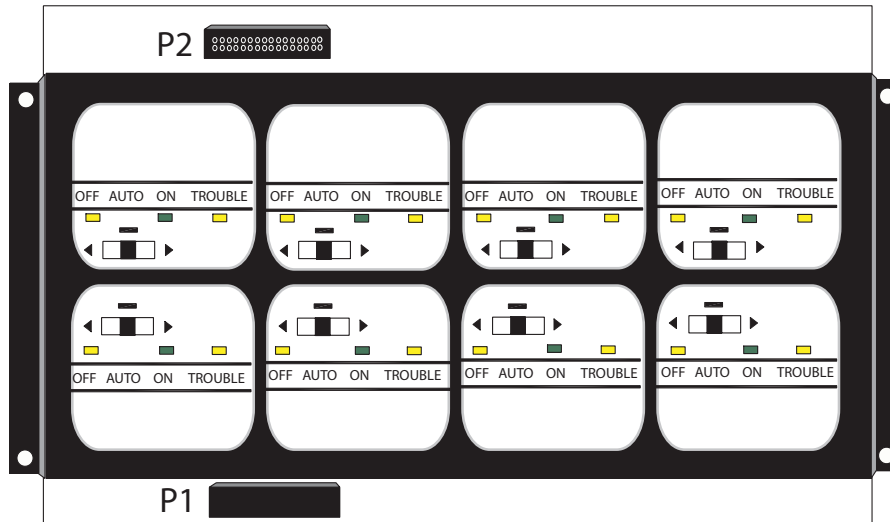

### Fan Damper Operation

The FDX-008 Fan Damper Control Display module has eight configurable output circuits, each with a three position switch. The FDX-008KI operates in the same manner as the FDX-008 except zone 8 is controlled by a remote keyswitch. Each switch has an ON and OFF position, plus an AUTO position. If the switch is placed in the AUTO position, the output will activate as programmed or configured. The output can be manually turned ON or OFF by placing the switch in the ON or OFF position, respectively.

Basically each switch can be configured to operate multiple fans or dampers. For each switch, there are 3 operations provided; outputs to turn ON, same outputs to turn OFF and inputs to bypass.

An example of the most common use of the FDX-008 or FDX-008KI Fan Damper Control Display module is to operate exhaust fans and confirm fan operation (via monitor modules). See FDX-008 Block Diagram on the next page for a block diagram of fan and monitor set up.

### Example

As shown in the figure to the right, Parking Garage #1 has 3 exhaust fans. The three position switch is configured to operate (to turn ON) fans 1, 2 and 3 in stairwell #1. The switch is set in the AUTO position. Upon activation (via alarm or some other programmed trigger) with the switch in AUTO, the 3 fans (1,2, and 3) in stairwell #1 are turned ON automatically. Monitor modules in the Parking Garage #1 detect that all 3 fans are operating, therefore the ON LED will illuminate steadily. If one of the fans did not turn ON (due to malfunction), both the ON and OFF LEDs will flash at the slow trouble rate. The TRBL (trouble) LED will illuminate steady amber based on feedback from the monitor module that one or more of the fans is not working.

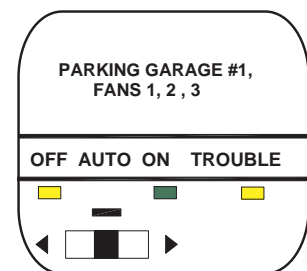

ON LED shows steady for all outputs operating and confirmed.

OFF LED shows steady for all outputs NOT operating and confirmed.

TRBL LED shows steady for one or more outputs NOT operating and confirmed.



**Note:** A bypass function always has priority, so that if a circuit is bypassed by moving the switch manually or by loop bypass (FX-2000N Fire Alarm Panel), no other action will operate this switch other than again moving the switch manually or by un-bypassing the loop.

**Figure 16: FDX-008 Block Diagram of Fan and Monitor Set-up**

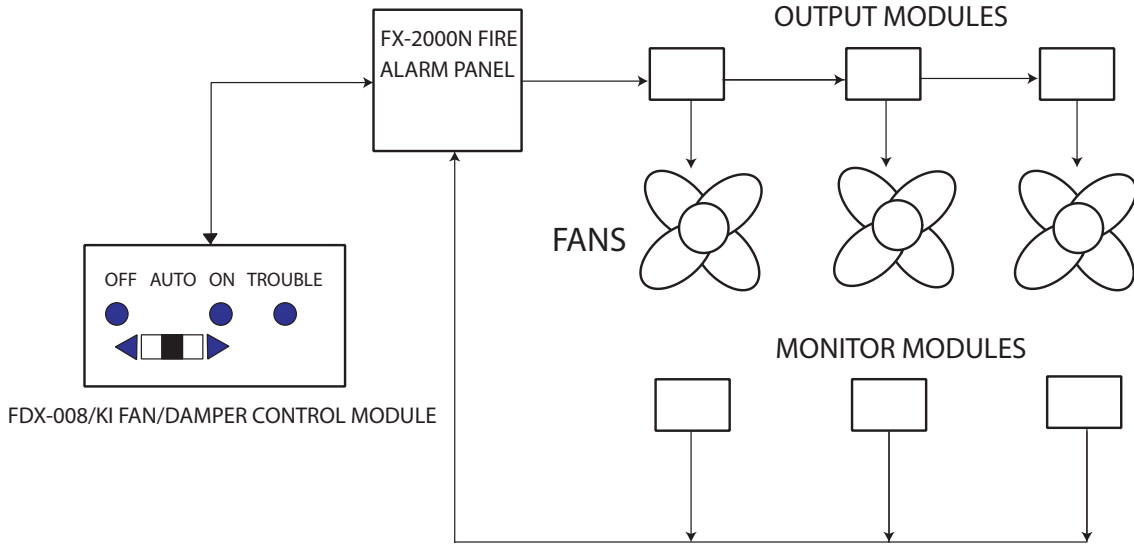

Before mounting the FDX-008KI module, if a keyswitch is to be connected, wire the keyswitch to terminals at TS1 as shown in Figure 17 below. Mount the FDX-008 and FDX-008KI Fan Damper Control Display modules in any position on the front part of the FX-2000N chassis and backbox.

**Figure 17: FDX-008KI Fan Damper Control Display Module**

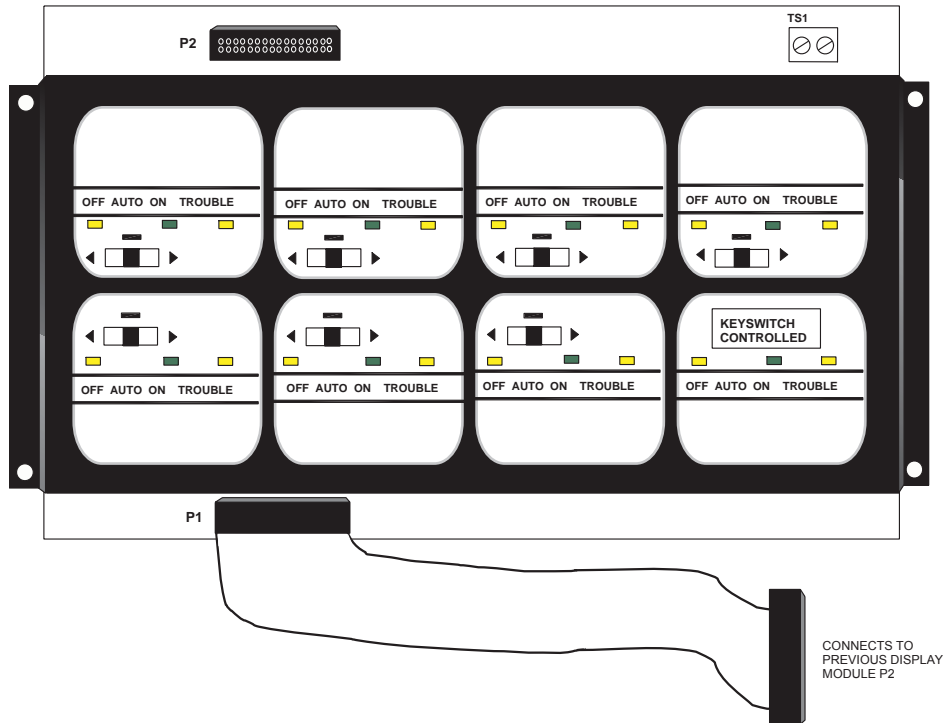

**Note:** There are also terminals located behind TS1 on the other side of the board for the convenience of wiring the keyswitch. The last fan damper zone in the bottom right position of the FDX-008KI is controlled by the keyswitch.

**UUKL with FDX-008 and FDX-008KI**

The models FDX-008 and FDX-00KI can be effectively use to provide an automatic and manual control system for smoke. Refer to document number LT-966 for extensive instructions regarding UUKL applications.

**Figure 18: Hardwire Detection Adder Module (DM-1008A)**

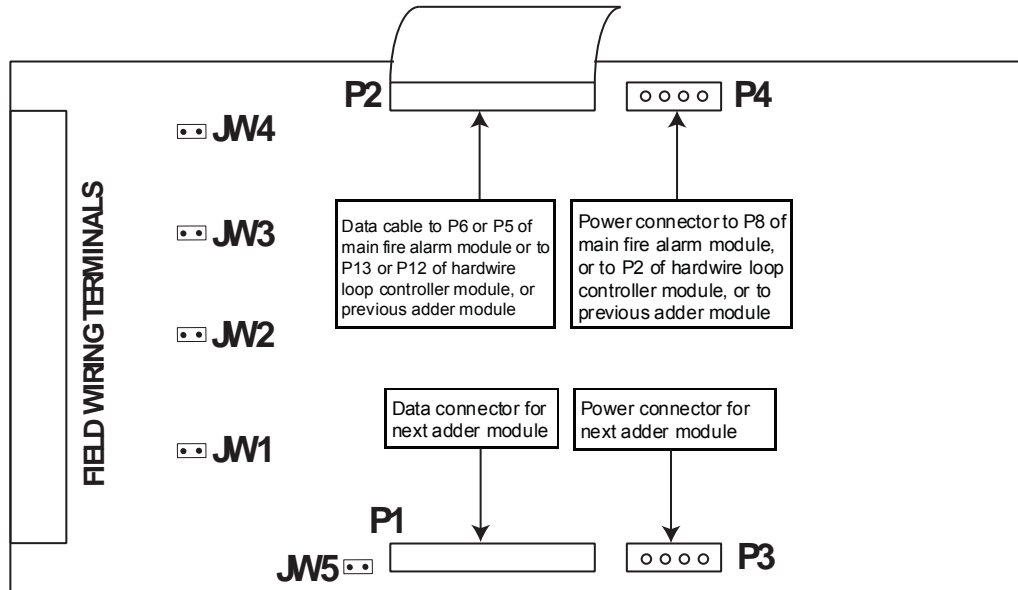

- JW1:** Install jumper for Class A (Style D) operation of initiating circuits 1 and 2.
- JW2:** Install jumper for Class A (Style D) operation of initiating circuits 3 and 4.
- JW3:** Install jumper for Class A (Style D) operation of initiating circuits 5 and 6.
- JW4:** Install jumper for Class A (Style D) operation of initiating circuits 7 and 8.
- JW5:** Remove continuity jumper if there are any more adder modules installed.

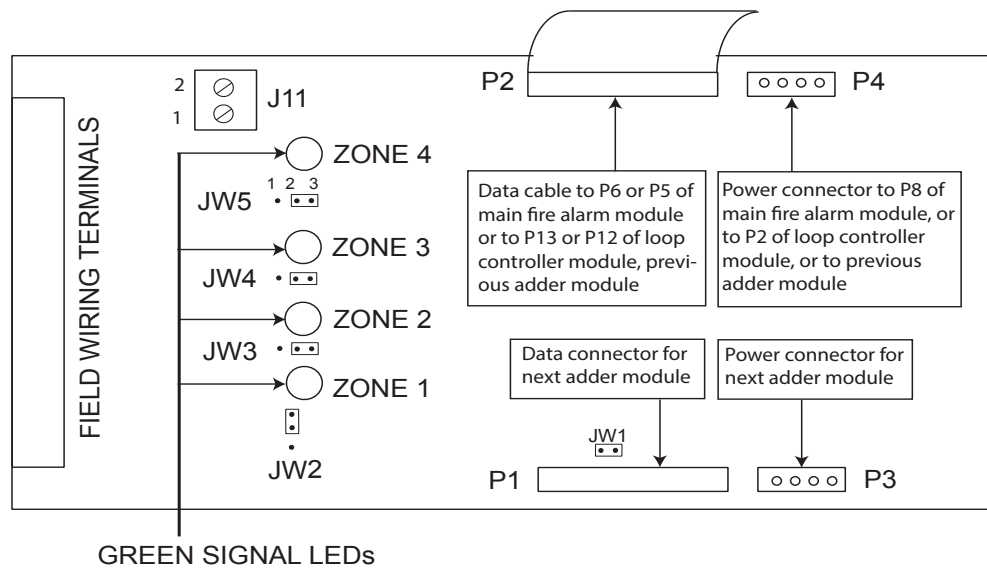

**Note:** For Class A (Style D) operation the FX-2000N must be configured as Class A via the configuration program.

**Figure 19: Hardwire Signal Adder Module (SGM-1004A)**

## Basic Mode

Jumpers on the SGM-1004A Signal Adder Module and their functions:

**JW1:** Remove continuity jumper if this is not the last adder module installed.

**JW2, JW3, JW4, and JW5:** Leave these jumpers open, on positions 2 and 3.

**J11 Terminals:** Not connected.

## Components

There are four green LEDs on the board, one for each signal zone. The LED will illuminate or flash following the signal rate sent to its zone. It will be off when the system is normal and they will illuminate when a signal zone is activated. The LED does not reflect what is happening on the signal zone, just that it is receiving data to activate that signal zone.



**Note:** Jumpers JW2, JW3, JW4 and JW5 are positioned on pins 2 and 3 (right two pins with board orientation as shown above) from factory.

## Operation

There are two modes of operation for this module. The basic mode of operation does not involve any isolators connected to the signal zones. For this case, leave jumpers JW2, JW3, JW4 and JW5 as they come on pins 2 and 3, and do not make any connection to terminal block J11. The second mode provides mode is used when isolators are to be connected to the signal circuits. For further information on bell cut relays or isolators, please refer to the specific fire alarm panel manual or the isolator instruction manual.

## Isolator Mode

### Jumpers for the Isolator Mode

**JW2:** Place jumper over pins 2 and 3 for the ability to connect an isolator on Zone 1.

**JW3:** Place jumper over pins 2 and 3 for the ability to connect an isolator on Zone 2.

**JW4:** Place jumper over pins 2 and 3 for the ability to connect an isolator on Zone 3.

**JW5:** Place jumper over pins 2 and 3 for the ability to connect an isolator on Zone 4.



**ATTENTION:** Discard jumpers on zones that are not configured for isolators.

**J11:** Wire these terminals to an alarm relay. These may be tapped if more signal modules are used in this manner.

**Figure 20: Hardwire Relay Adder Module (RM-1008A)**

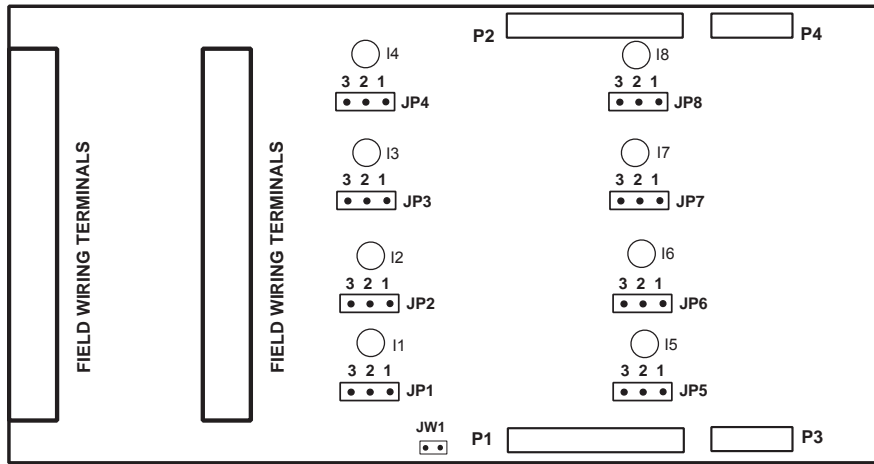

**P2:** Data cable to P6 or P5 of main fire alarm module, or to previous adder module.

**P1:** Data connector for next adder module.

**P4:** Power connector to P8 of main fire alarm module, or to previous adder module.

**P3:** Power connector for next adder module.

**JW1:** Remove continuity jumper if there are any more adder modules installed. If this is the last module installed, leave JW1 on.

**JP1-JP8:** Move jumpers from pins 1 and 2 to 2 and 3 to connect relay commons between two or more relays.

**Polarity Reversal and City Tie Module (Model PR-300)**

**Figure 21: Polarity reversal and city tie module**

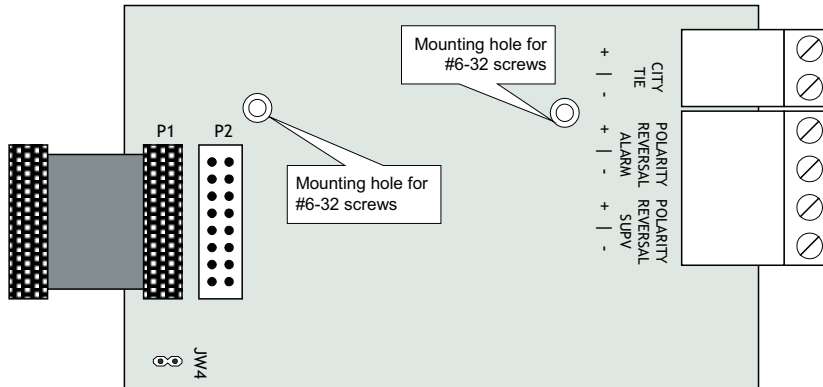

The following hardware configuration must be performed before installing the PR-300.

**Table 5: PR-300 jumper settings**

|            |  |
|------------|--|
| <b>P1</b>  | Cable connects to <b>P4</b> on the <b>FX-2000N Main Fire Alarm Board</b>   |
| <b>P2</b>  | Not used. If a UDACT-300A is used in conjunction with a PR-300, then the UDACT-300A ribbon cable P1 is connected to header P2 of the PR-300. |
| <b>JW4</b> | Jumper JW4 is always left intact.  |

The Alarm Transmit signal to the PR-300 can be programmed to turn OFF when signal silence is active (Not allowed by UL 864 refer to Configuration section). This allows the City Tie Box to be manually reset. On subsequent alarms the silenceable signals will resound and the City Tie Box will be retriggered. Please refer to the Configurator for more information.

The Trouble Transmit signal to the PR-300 can be programmed to delay AC power fail. Please refer to the Configurator for more information.



**Note:** Jumper JW4 on the FX-2000N main fire alarm board must be removed if a city tie module is installed.



**UDACT-300A MAIN BOARD:**

There are two jumpers on the UDACT-300A which are used for operation/configuration purposes. Jumper JW1 is used to reset the default passcode. Jumper JW2 is required for configuring (which can be done using the FX-2000N Configurator Software) the UDACT-300A. Refer to Figure 22 below for location of jumpers, cable connections, pushbutton and LEDs. Table 6 following, provides a description of the user items on the UDACT-300A.

**Figure 22: UDACT-300A Board Layout**

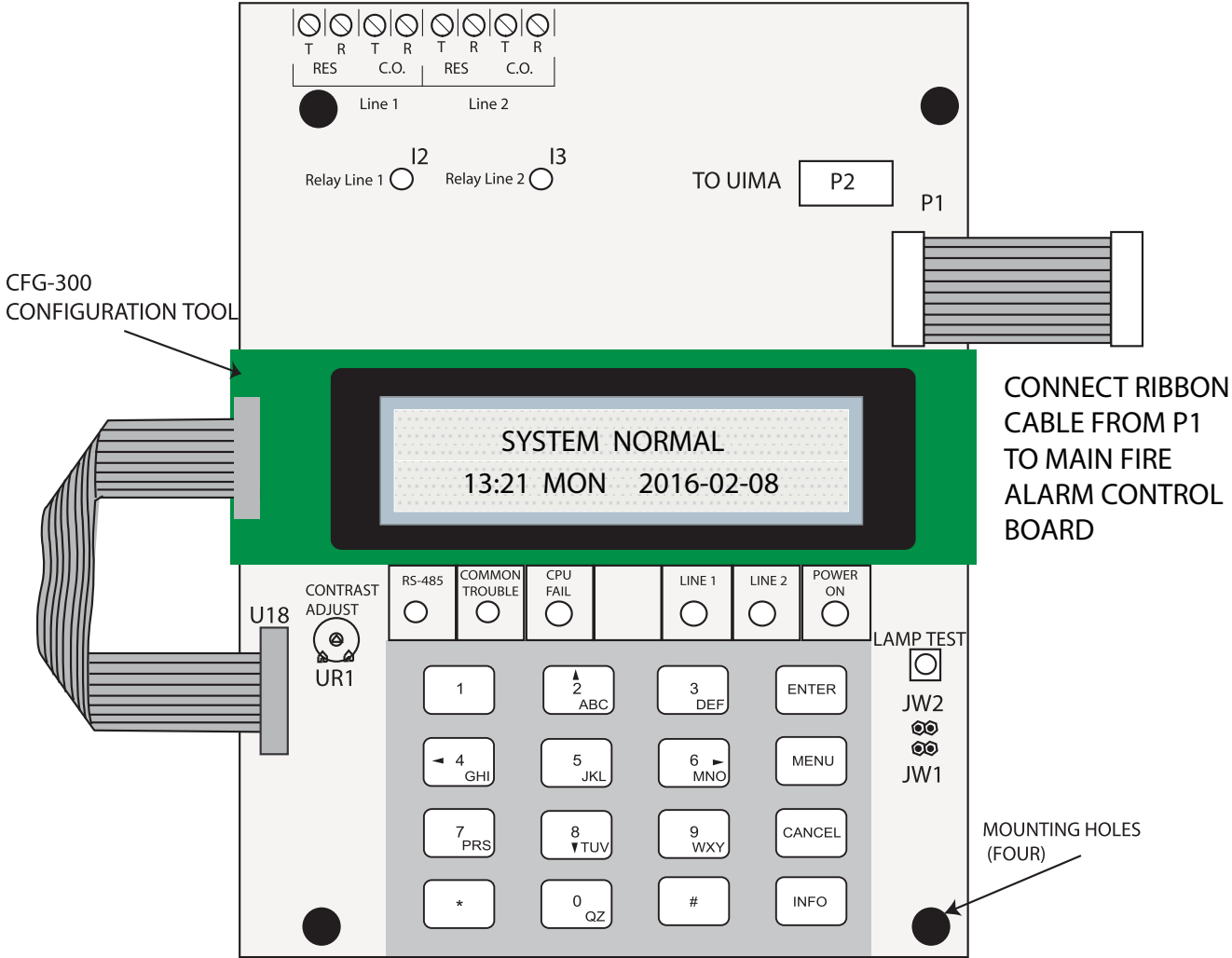

**Table 6: UDACT-300A Cable Connectors and Miscellaneous**

| Cable Connector          | Function  |
|--------------------------|---|
| <b>P1</b>                | Ribbon Cable for connecting to P4 of FX-2000N main fire alarm module or to P2 header on the PR-300 if used. |
| <b>P2</b>                | RS-232C/RS-485 Connection for computer configuration.   |
| <b>U18</b>               | Connector for CFG-300 Configuration Tool  |
| <b>Lamp Test button</b>  | Press and hold this button to test all the UDACT-300A LEDs  |
| <b>UR1 Potentiometer</b> | This potentiometer is for adjustment of the CFG-300 LCD contrast.   |

The following table lists all the LEDs located on the UDACT-300A board and states the function of each LED.

**Table 7: UDACT-300A List of LEDs and their Functions.**

| LEDs                    | LED Function   |
|-------------------------|--|
| <b>Relay Line 1</b>     | Located below Line 1 terminal block. When Line 1 relay is energized, this green LED will illuminate  |
| <b>Relay Line 2</b>     | Located below Line 2 terminal block. When Line 2 relay is energized, this green LED will illuminate. |
| <b>RS-485</b>           | Status LED for communication, will flash when RS-485 communication is active.                        |
| <b>Common Trouble</b>   | Steady amber for any troubles on the Fire Alarm panel or UDACT-300A.                                 |
| <b>CPU Fail</b>         | Steady amber for any on board CPU trouble.   |
| <b>Telephone Line 1</b> | Telephone status indicator LED; Red when the line is in use, Amber when there is a line trouble.     |
| <b>Telephone Line 2</b> | Telephone status indicator LED; Red when the line is in use, Amber when there is a line trouble.     |
| <b>Power ON</b>         | Green LED is ON steady when power is supplied to the board.  |

The following table lists the user jumpers available on the UDACT-300A and their functions.

**Table 8: UDACT-300A List of Jumpers for Operation and Configuration**

| Jumper Number | Jumper Function   |
|---------------|---|
| <b>JW1</b>    | Normally open. Place jumper here and power down the UDACT-300A by disconnecting P1 or power down the fire alarm panel (AC and Batteries), then power back to revert to default passcode. After reset, remove the jumper. Leave normally open. |
| <b>JW2</b>    | Normally open to BLOCK remote configuration via modem, PC with a UIMA converter module or using the LCD and keypad at the UDACT-300A. Place jumper here to ALLOW any type of configuration. Remove jumper once configuration is complete.     |



**Note:** This module cannot be installed if a city tie module is used.

See the *UDACT-300A Installation and Operation Manual LT-888* for more information.

## ALCN-792M Quad Loop Adder Module with ALCN-792D Daughter Board

The new Quad Loop Adder module provides two addressable loops plus an additional two loops as part of the daughter board ALCN-792D which is mounted over the ALCN-792M. The Quad Loop Adder module may be mounted over the main chassis of the FX-2000N Fire Alarm Panel or on any chassis that supports adder boards. Refer to the Display and Adder Modules section for mounting applications. This module is mounted using four #6 screws and (if necessary) four 1 1/2" spacers.

|                                |  |
|--------------------------------|--|
| <b>Power</b>                   | The power is supplied to the board via cable from the main fire alarm board or from the previous loop controller module into the P1 POWER IN connector. Connect the P2 POWER OUT connector to the next loop controller module or other adder module. One power cable is supplied with this module.   |
| <b>RS-485:</b>                 | The RS-485 cable comes attached at P3 and is either connected to P3 of the main fire alarm controller module or connected from the previous loop controller module or other adder board. If the next loop controller module is used, connect the RS-485 out at P4 to the next loop controller module; if it is not used, leave without connection. |
| <b>DIP Switches:</b>           | Use the DIP switches to set the binary address of the board. SW1-1 is the lowest significant digit and ON is active. For example, an address of two would be created by turning SW1-1 OFF, SW1-2 ON and DIP switches SW1-3 to SW1-8 OFF. Refer to Appendix C for DIP switch settings.  |
| <b>Loop 1:</b>                 | This is the addressable loop for all initiating devices. Wire the loop as shown in Figures Figure 30, Figure 31 and <i>Figure 32</i> .   |
| <b>Loop 2:</b>                 | This is the addressable loop for all initiating devices. Wire the loop as shown in Figures Figure 30, Figure 31 and <i>Figure 32</i> .   |
| <b>Jumpers:</b>                | A jumper is provided at JW2 for normal operation. To reset the board, leave the jumper at JW2 and momentarily short the pins at position JW1.  |
| <b>RS-232 Debug Interface:</b> | This connection is for factory use only.   |
| <b>JTAG Port:</b>              | This connection is for factory use only.   |

The ALCN-792D Daughter Board provides another two addressable loops when connected to the ALCN-792M Quad Loop Adder Board. This daughter board is mounted over the ALCN-792M. Wire the two addressable loops on the ALCN-792D Daughter Board in the same manner the ALCN-792M addressable loops are wired.

**Figure 23: ALCN-792D Daughter Board**

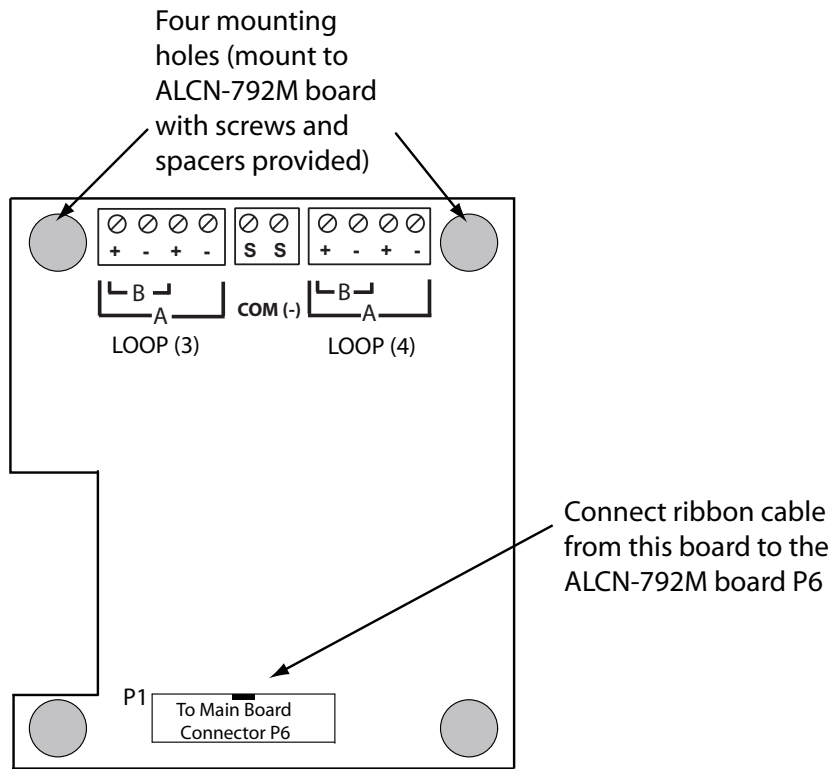

**Notes for ALCN-792D:**

- All circuits are power limited and must use type FPL, FPLR, or FPLP power limited cable.
- Loop wiring: maximum loop resistance is 40 ohms total. These lines power-limited and fully supervised.

Wire the ALCN-792M Quad Loop Adder module as shown in Figure 24 below.

**Figure 24: ALCN-792M Quad Loop Adder Module**

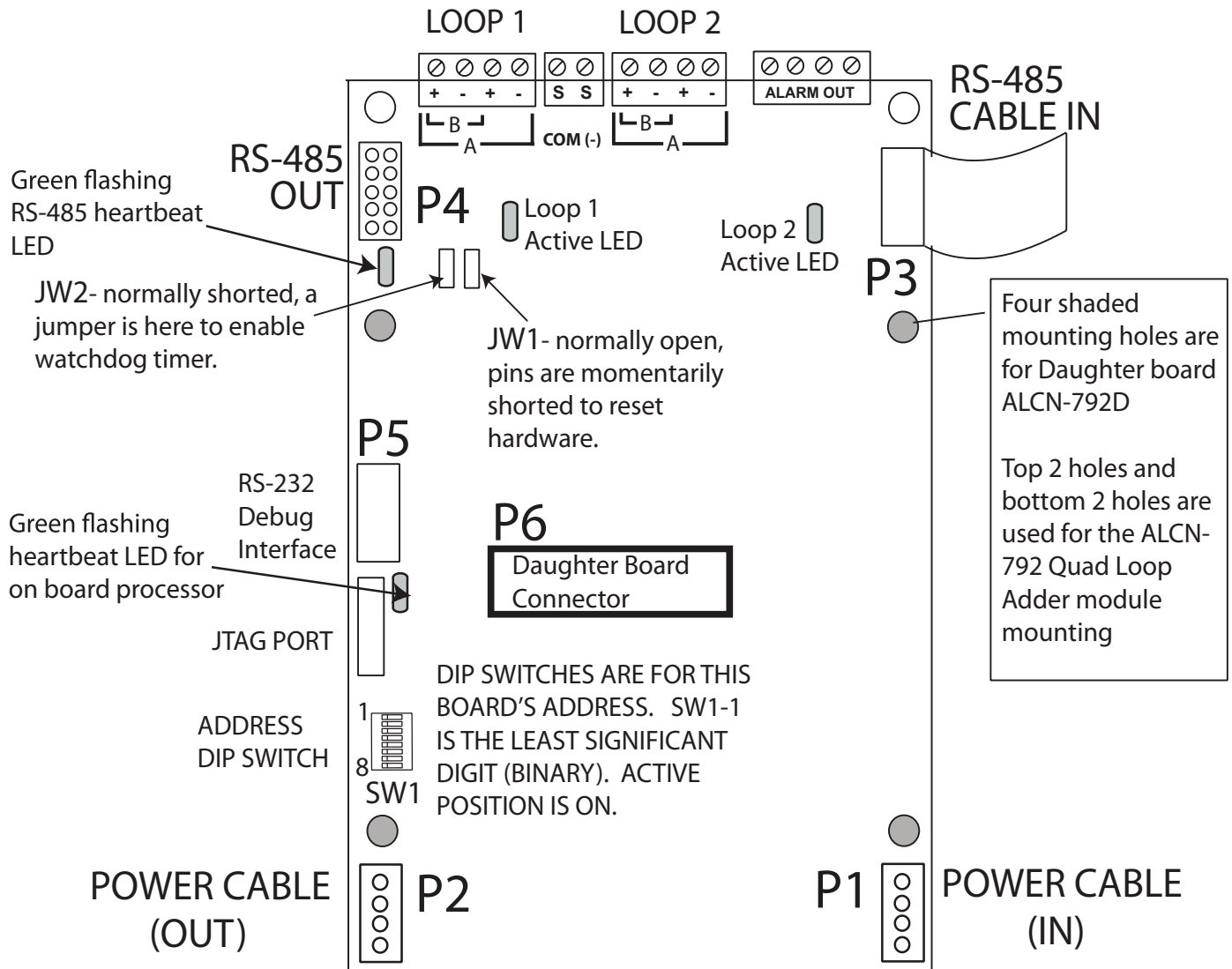

**Wiring The Addressable Loops**

There are two addressable loops present on this board that are wired in the same manner as shown in the wiring diagrams beginning with Figure 30. Although these drawings show only Loop 1; Loop 2 is wired in the same way as Loop 1 is.



**Notes for ALCN-792M:**

- All circuits are power limited and must use type FPL, FPLR, or FPLP power limited cable.
- Loop wiring: maximum loop resistance is 40 ohms total. These lines power-limited and fully supervised.

# Field Wiring

## Main Fire Alarm Module Terminal Connections

Wire devices to terminals as shown in Figure 25 below. Refer to Appendix A for specifications and to LT-1023 for compatible devices.



**ATTENTION:** Do not exceed power supply ratings:

Main Chassis: FX-2003-12NDS, FX-2003-12NXTDS, FX-2009-12NDS or FX-2017-12NDS: total current for NACs is 10A max.



**Notes:**

The terminal blocks are removable for ease of wiring.

All power limited circuits must use type FPL, FPLR, or FPLP power limited cable.

**Figure 25: Main Fire Alarm Controller Board Field Terminal Connections**

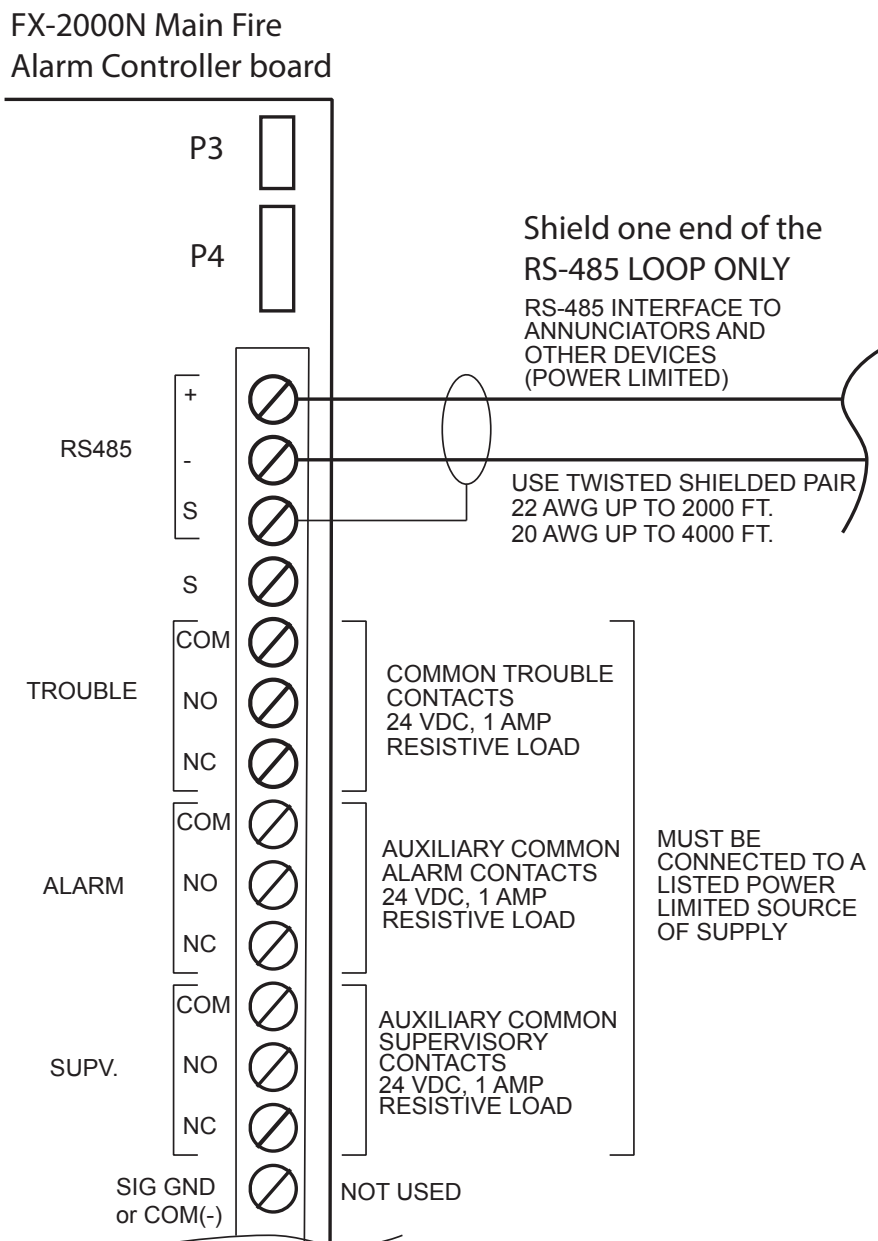

**Figure 26: Main Fire Alarm Control board Field Terminal Connections (continued)**

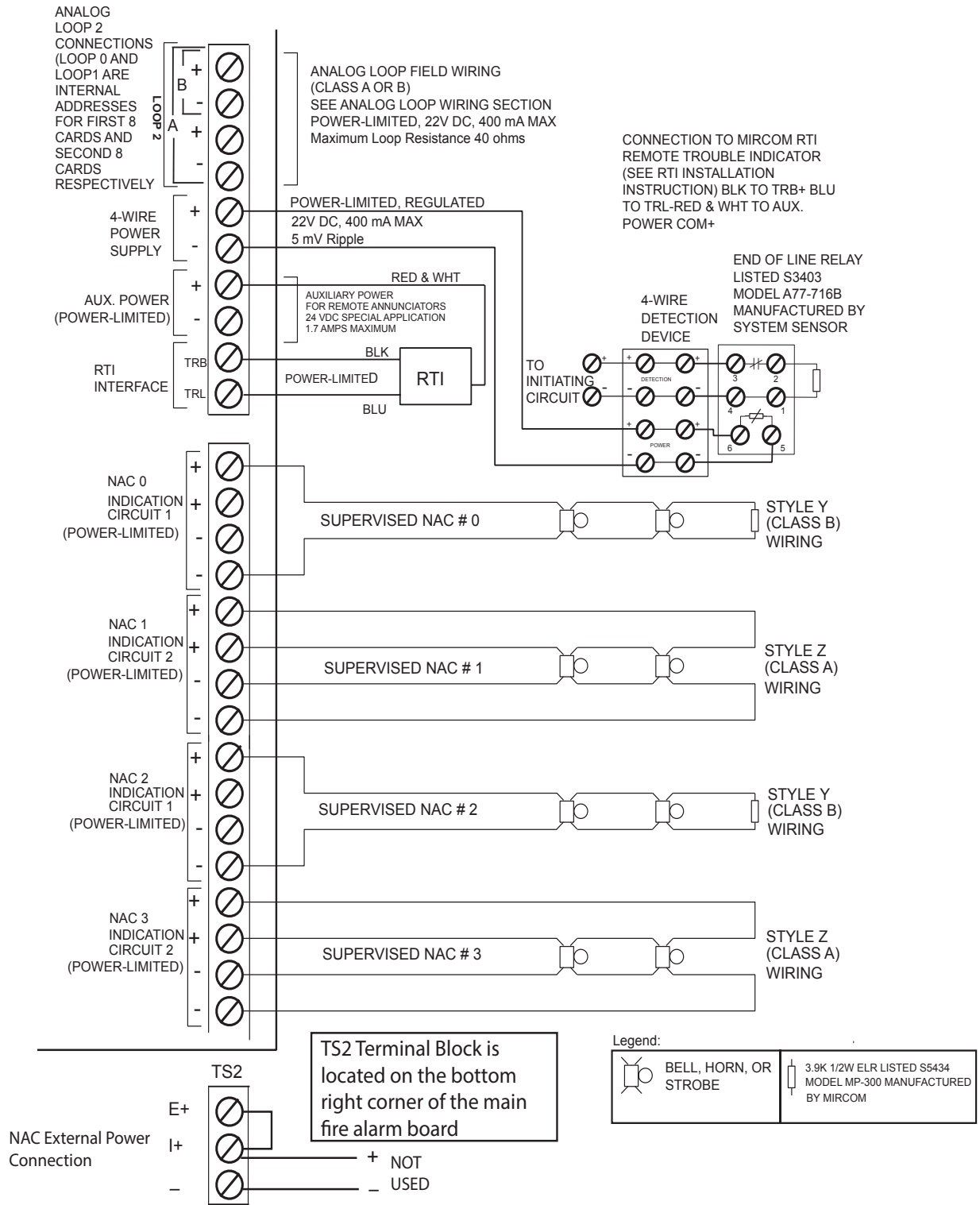

- Notes:**
- All circuits are power limited (unless marked otherwise) and must use type FPL, FPLR, or FPLP power limited cable.
  - NACs are fully supervised and rated for 24 VDC special application, 1.7A max. They must be wired as shown in the *Wiring Tables and Information* section.

## Analog Loop Wiring

Figure 27: Loop Terminal Connections - Class B

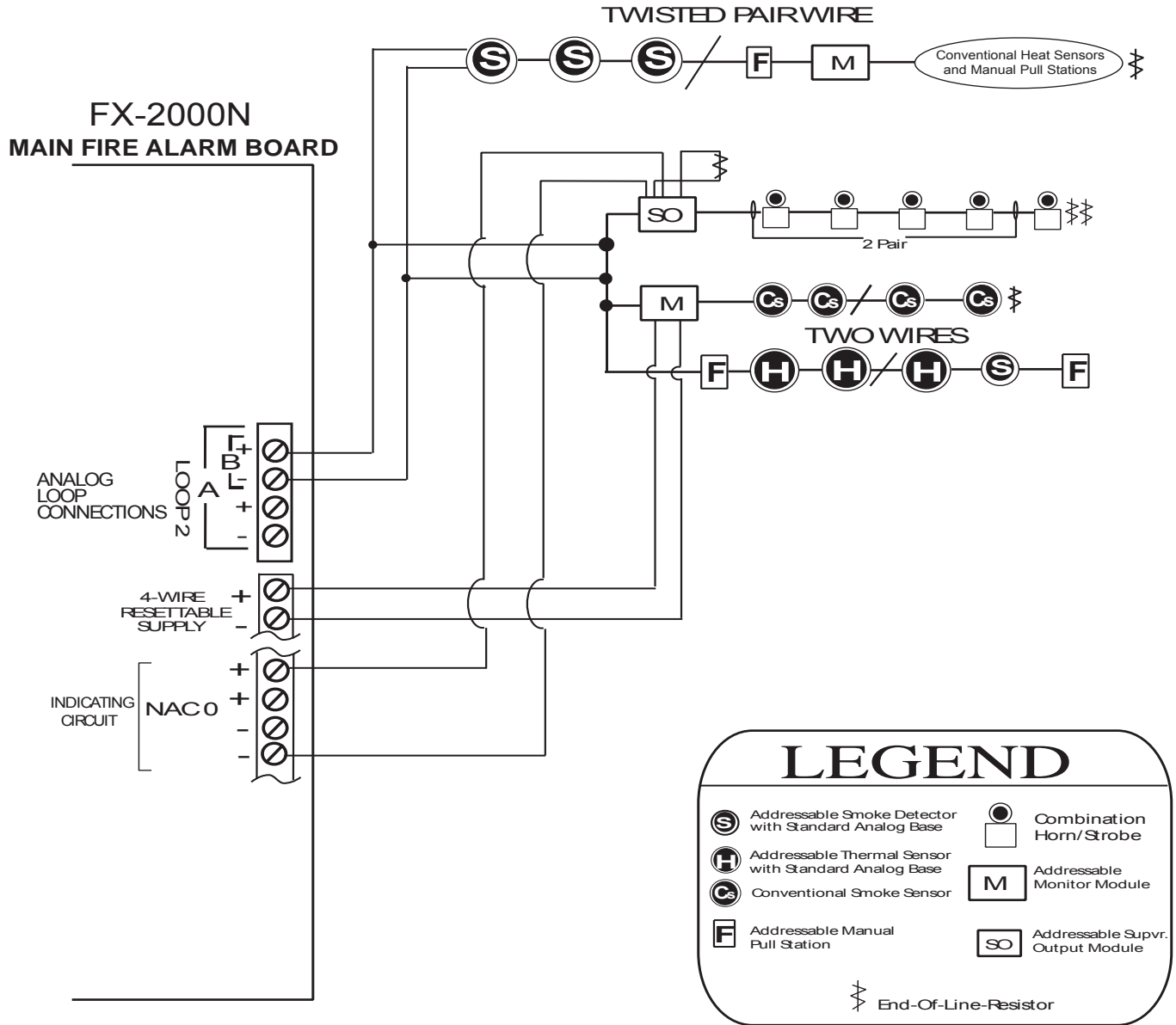

**Notes:**

- Terminal blocks are “depluggable” for ease of wiring.
- All power limited circuits must use type FPL, FPLR, or FPLP power limited cable.
- Loop wiring: maximum loop resistance is 40 ohms total. These lines are power limited and fully supervised.
- Observe in and out polarity when using module and base isolators.



Figure 28: Loop Terminal Connections - Style 7

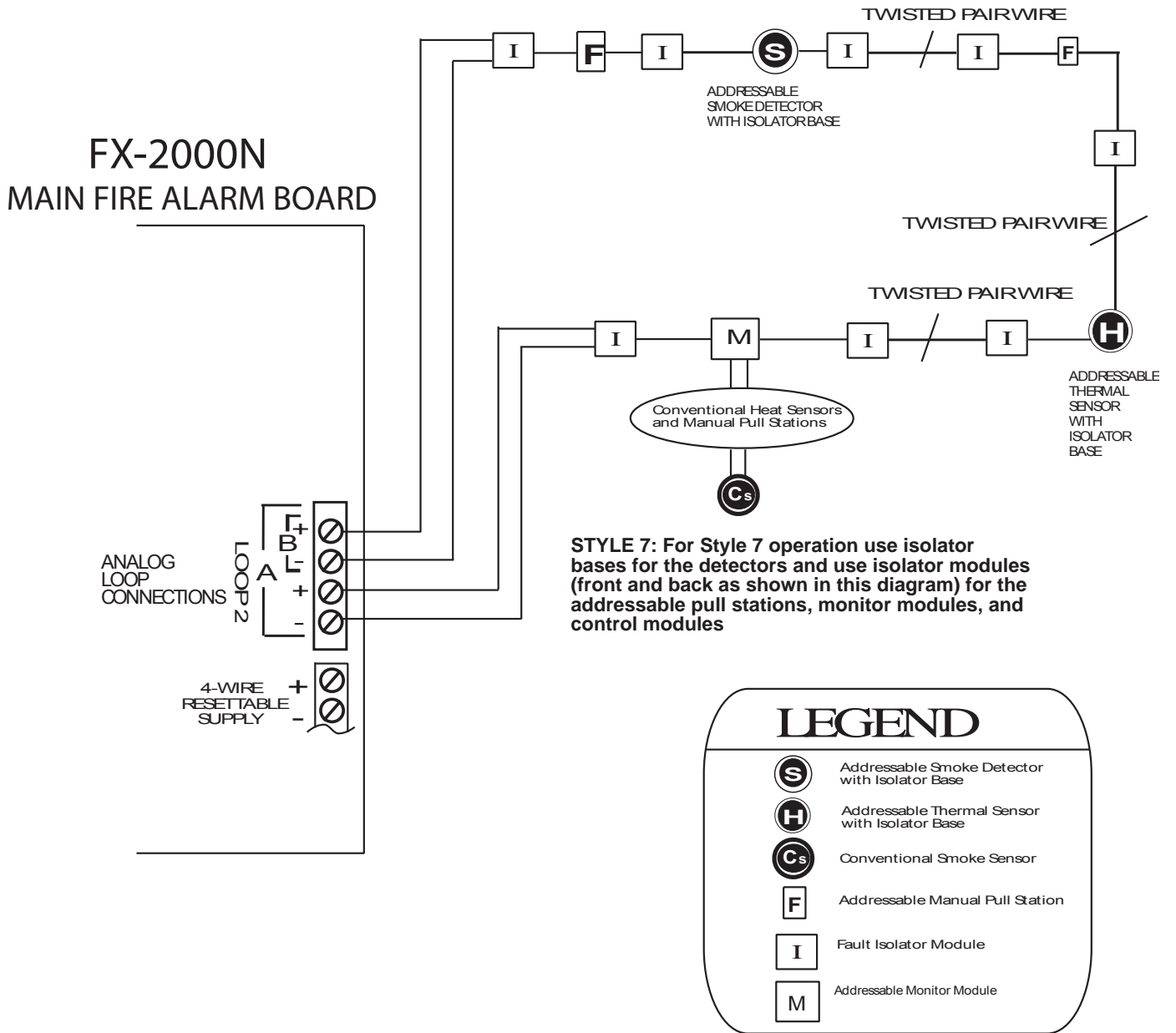

**Notes:**

- All power limited circuits must use type FPL, FPLR, or FPLP power limited cable.
- Isolators need to be close nipple connected to the device being protected.
- Loop wiring: maximum loop resistance is 40 ohms total. These lines are power- limited and fully supervised.

Figure 29: Loop Terminal Connections - Style 6 (Formerly Class A)

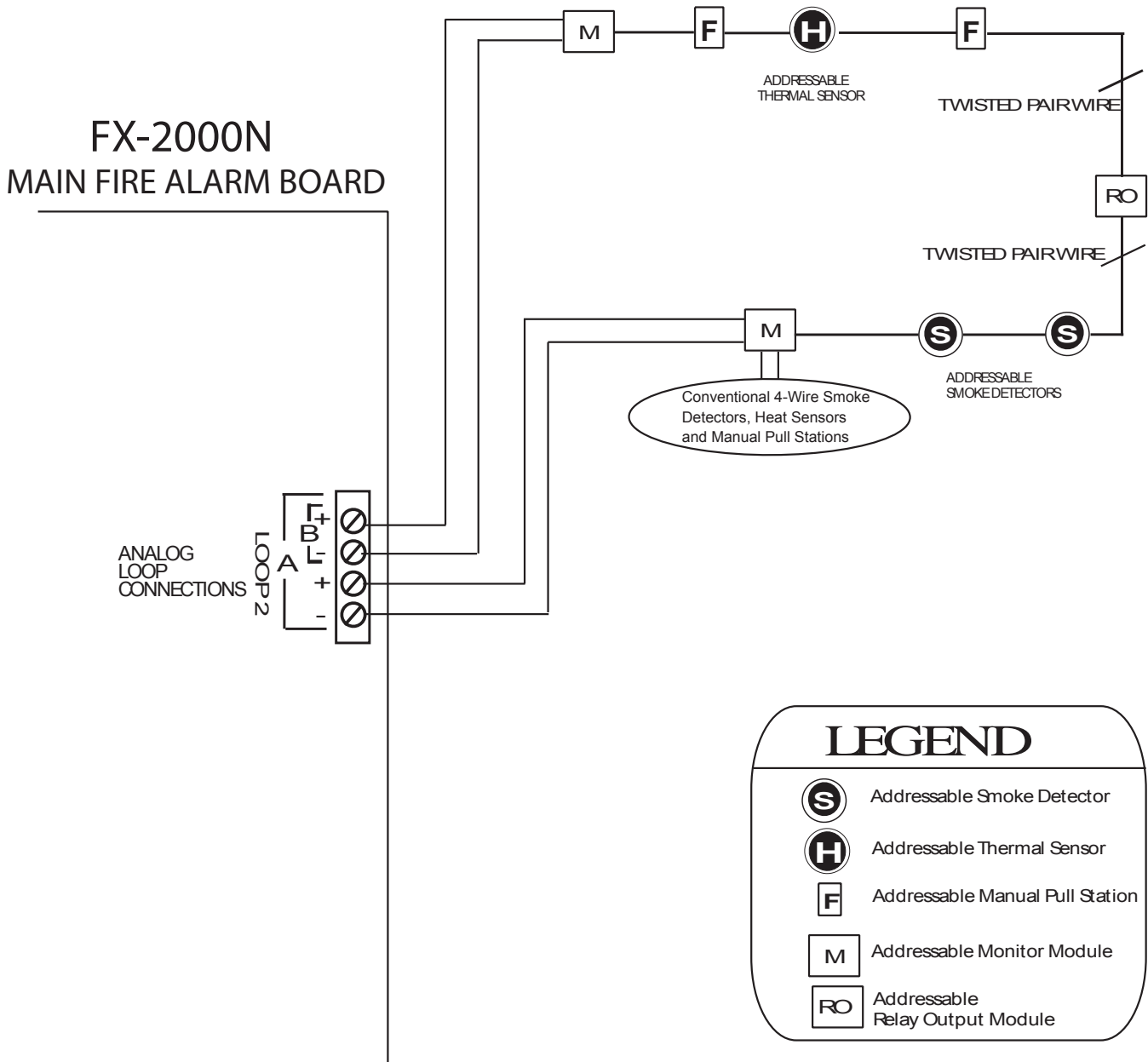

**LEGEND**

|      |                                 |
|------|---------------------------------|
| (S)  | Addressable Smoke Detector      |
| (H)  | Addressable Thermal Sensor      |
| [F]  | Addressable Manual Pull Station |
| [M]  | Addressable Monitor Module      |
| [RO] | Addressable Relay Output Module |



- Notes:**
- All power limited circuits must use type FPL, FPLR, or FPLP power limited cable.
  - Loop wiring: maximum loop resistance is 40 ohms total. These lines power-limited and fully supervised.

Figure 30: Quad Loop Terminal Connections - Class B

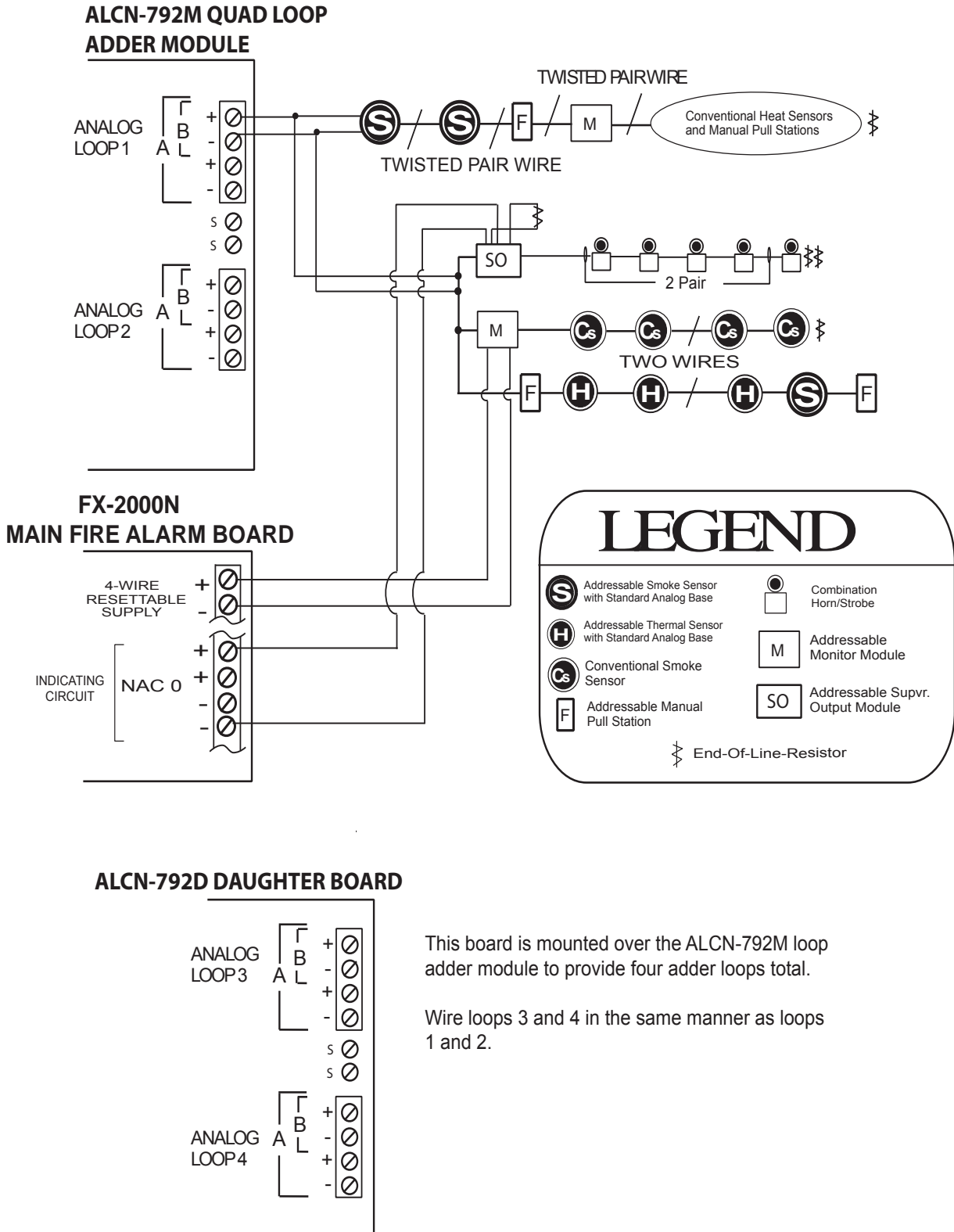

**Notes:**

- All power limited circuits must use type FPL, FPLR, or FPLP power limited cable.
- Loop wiring: maximum loop resistance is 40 ohms total. These lines are power-limited and fully supervised.

**Figure 31: Quad Loop Adder Module Terminal Connections - Style 7**



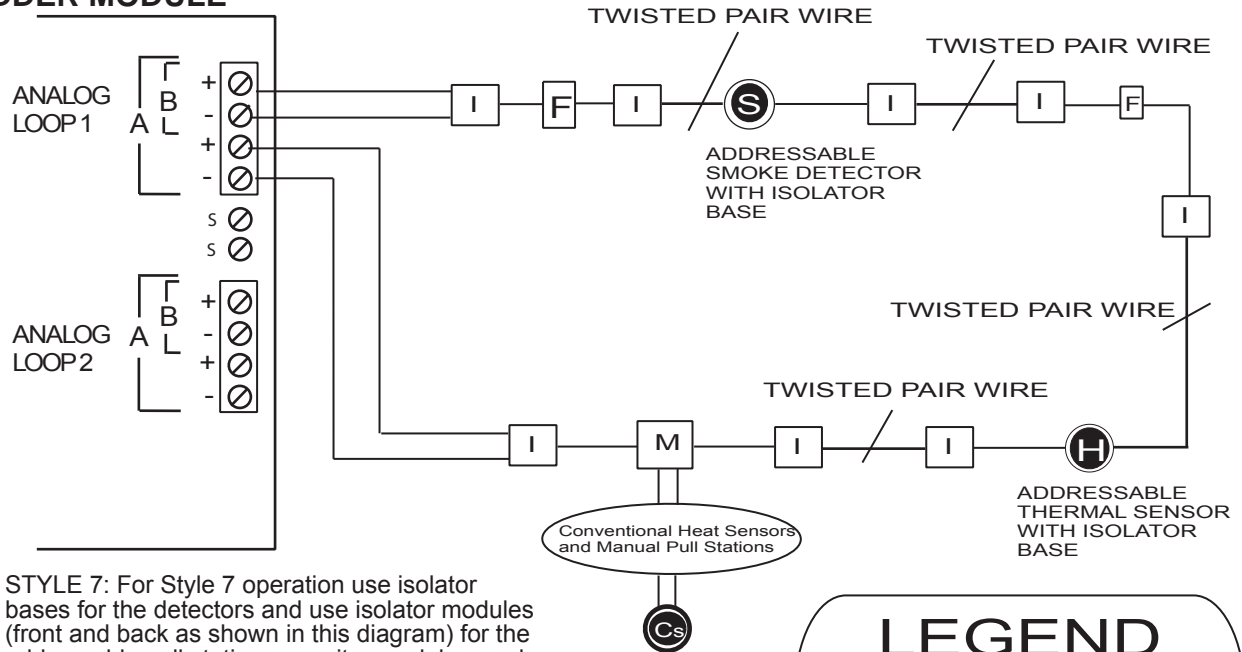



**ALCN-792M QUAD LOOP  
ADDER MODULE**



STYLE 7: For Style 7 operation use isolator bases for the detectors and use isolator modules (front and back as shown in this diagram) for the addressable pull stations, monitor modules, and control modules

TWISTED SHIELDED PAIR WIRE IS NOT RECOMMENDED. IF USED THE SHIELD SHOULD BE TERMINATED AT THE TERMINALS MARKED SHIELD

## LEGEND

|   |   |
|---|---|
|    | Addressable Smoke Sensor with Isolator Base   |
|   | Addressable Thermal Sensor with Isolator Base |
|  | Conventional Smoke Sensor                     |
|  | Addressable Manual Pull Station               |
|  | Addressable Monitor Module                    |
|  | Fault Isolator Module                         |

**ALCN-792D DAUGHTER BOARD**

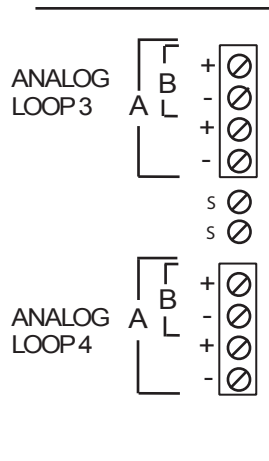

This board is mounted over the ALCN-792M to provide an additional two loops, for a total of four loops.

Wire loops 3 and 4 in the same manner as loops 1 and 2.



**Notes:**

- All power limited circuits must use type FPL, FPLR, or FPLP power limited cable.
- Isolators need to be close nipple connected to the device being protected.
- Loop wiring: maximum loop resistance is 40 ohms total. These lines are power-limited and fully supervised.

**Figure 32: Quad Loop Adder Module Terminal Connections - Style 6**

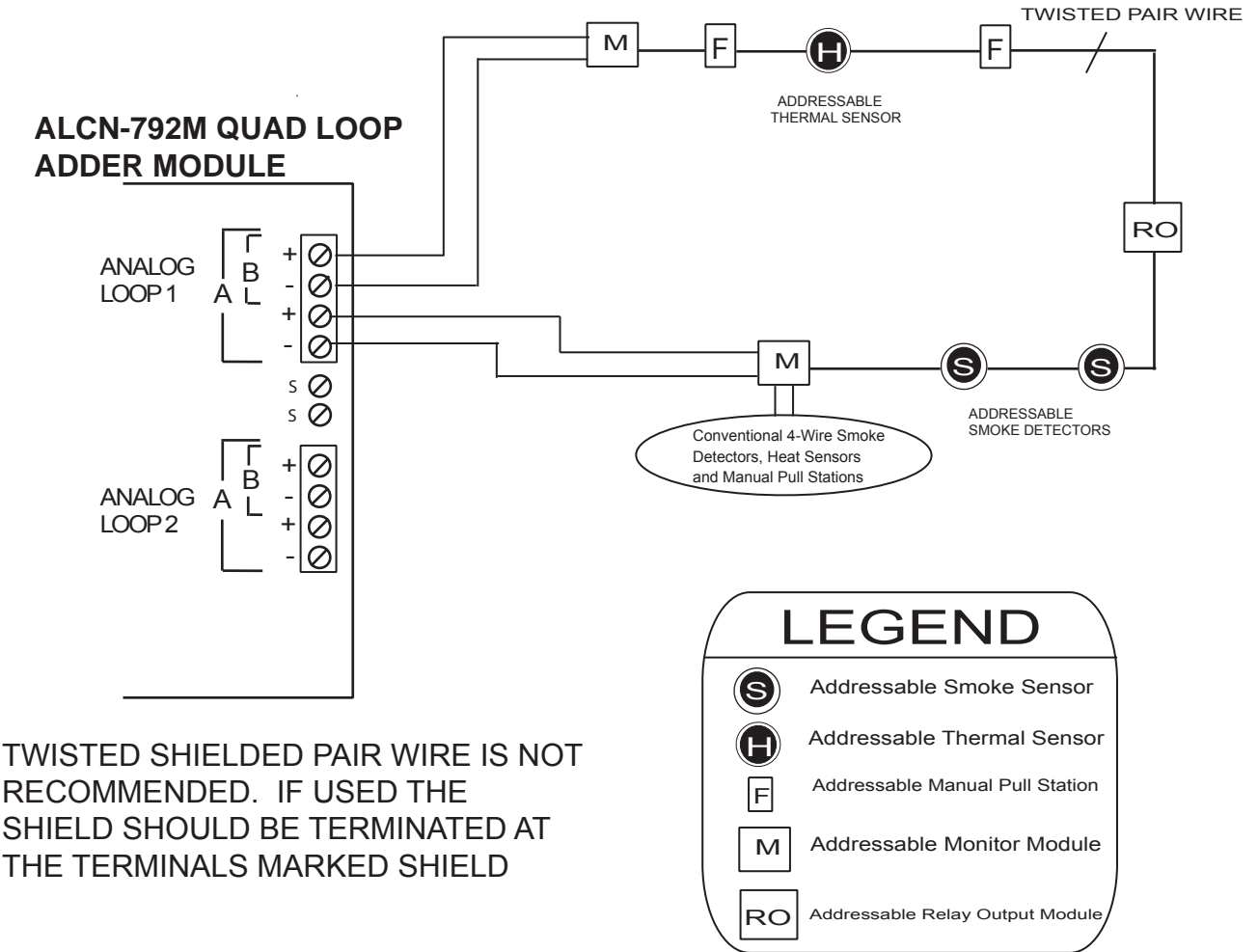

**ALCN-792D DAUGHTER BOARD**

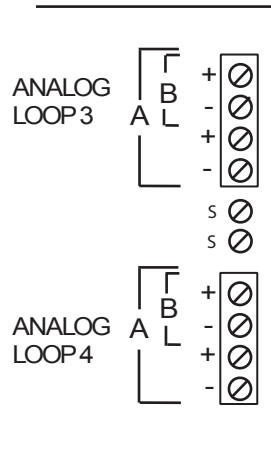

This board is mounted over the ALCN-792M loop adder module to provide an addition two loops, for a total of four loops.

Wire loops 3 and 4 in the same manner as loops 1 and 2.



**Notes:**

- All power limited circuits must use type FPL, FPLR, or FPLP power limited cable.
- Loop wiring: maximum loop resistance is 40 ohms total. These lines are power-limited and fully supervised.

## FNC-2000 Fire Network Controller Module

The FNC-2000 Fire Network Controller modules are wired from terminals marked Line A, positive and negative (see specific cable recommended in Figure 33 to the Line B terminals of the next FNC-2000 module. **Use of shielded cable is not recommended.** Wire from Line B terminals to Line A of the next FNC-2000 module. Start from the lobby panel and wire to all the FNC-2000, wiring the last FNC-2000 back to Line B of the first FNC-2000 at the lobby panel for Class A.

**Figure 33: Style 7 Wiring for the FNC-2000 Module**

### STYLE 7 WIRING

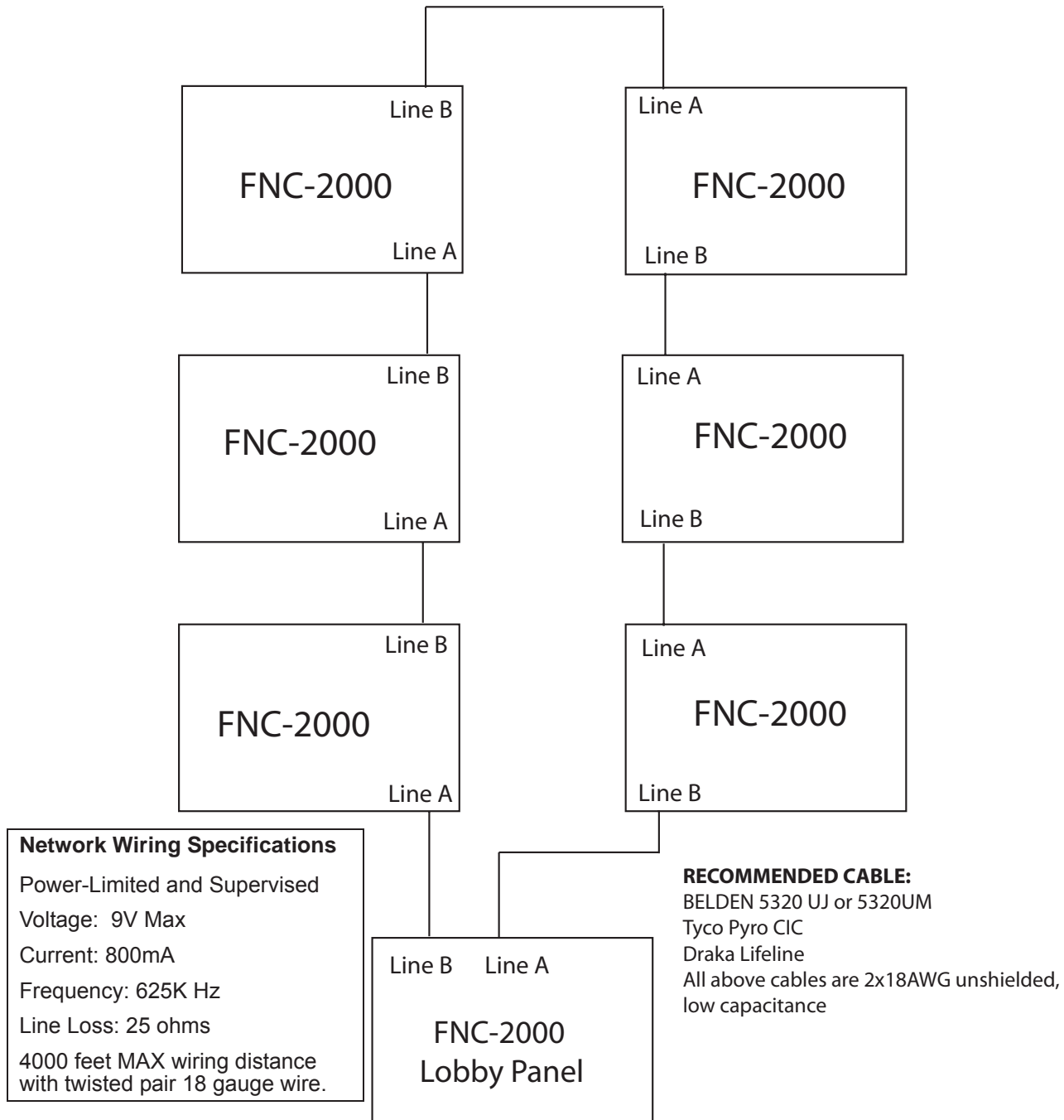

### FOM-2000-SP Fiber Optic Network Adder Module

The FOM-2000-SP Fiber Optic Network Adder Module is wired with fiber optic cable. It is wired OUT through the transmit connectors marked TX and IN through the receive connectors marked RX.

**Figure 34: FOM-2000-SP Fiber Optic Network Adder Module Wiring**

### STYLE 7 WIRING

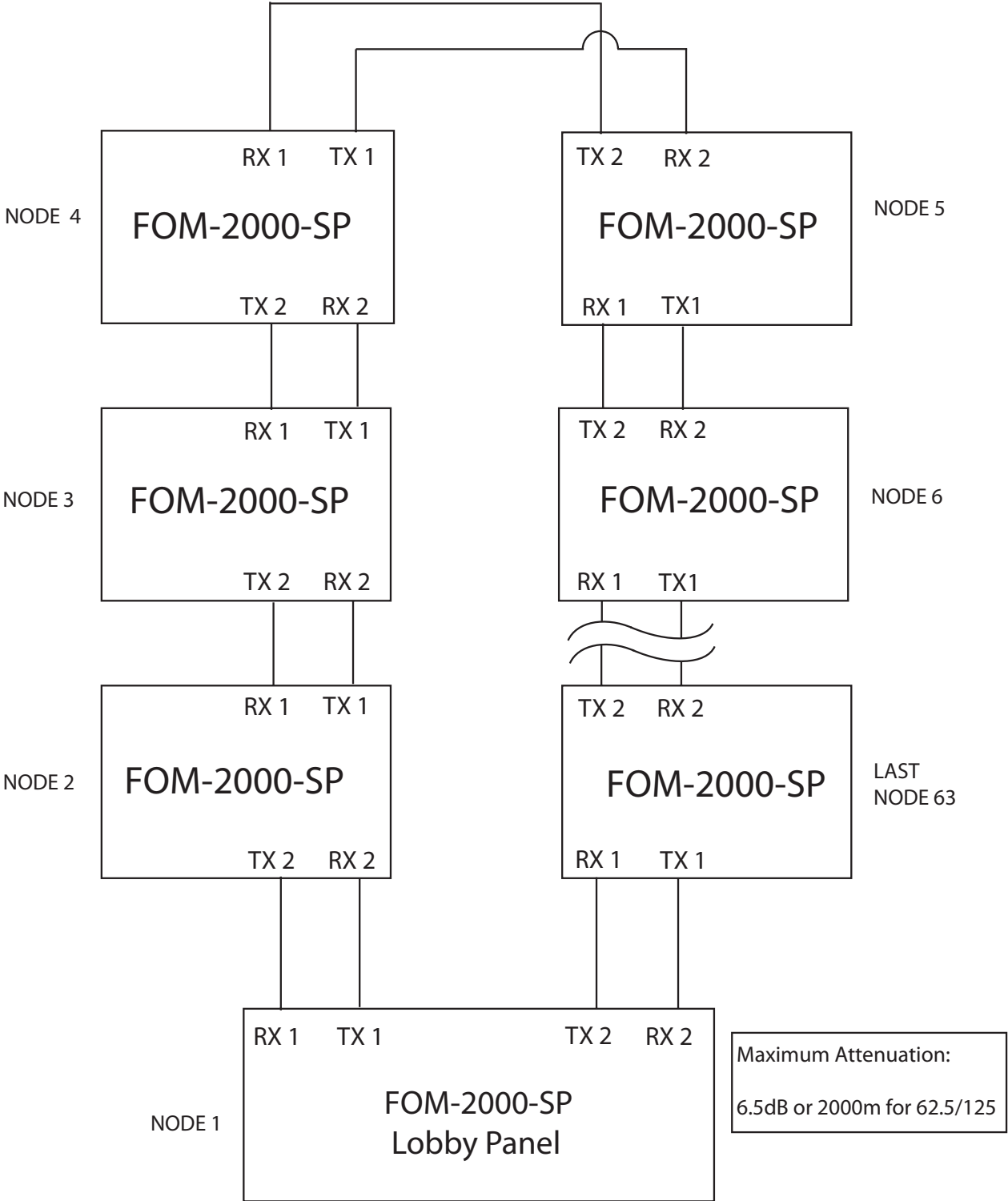

## Detection Module (DM-1008A) Terminal Connections

Wire devices to terminals as shown below. See wiring tables, and Appendix A for electrical specifications and document LT-1023 for compatible devices.

**Figure 35: Hardwire Detection Module (DM-1008A) Terminal Connections**

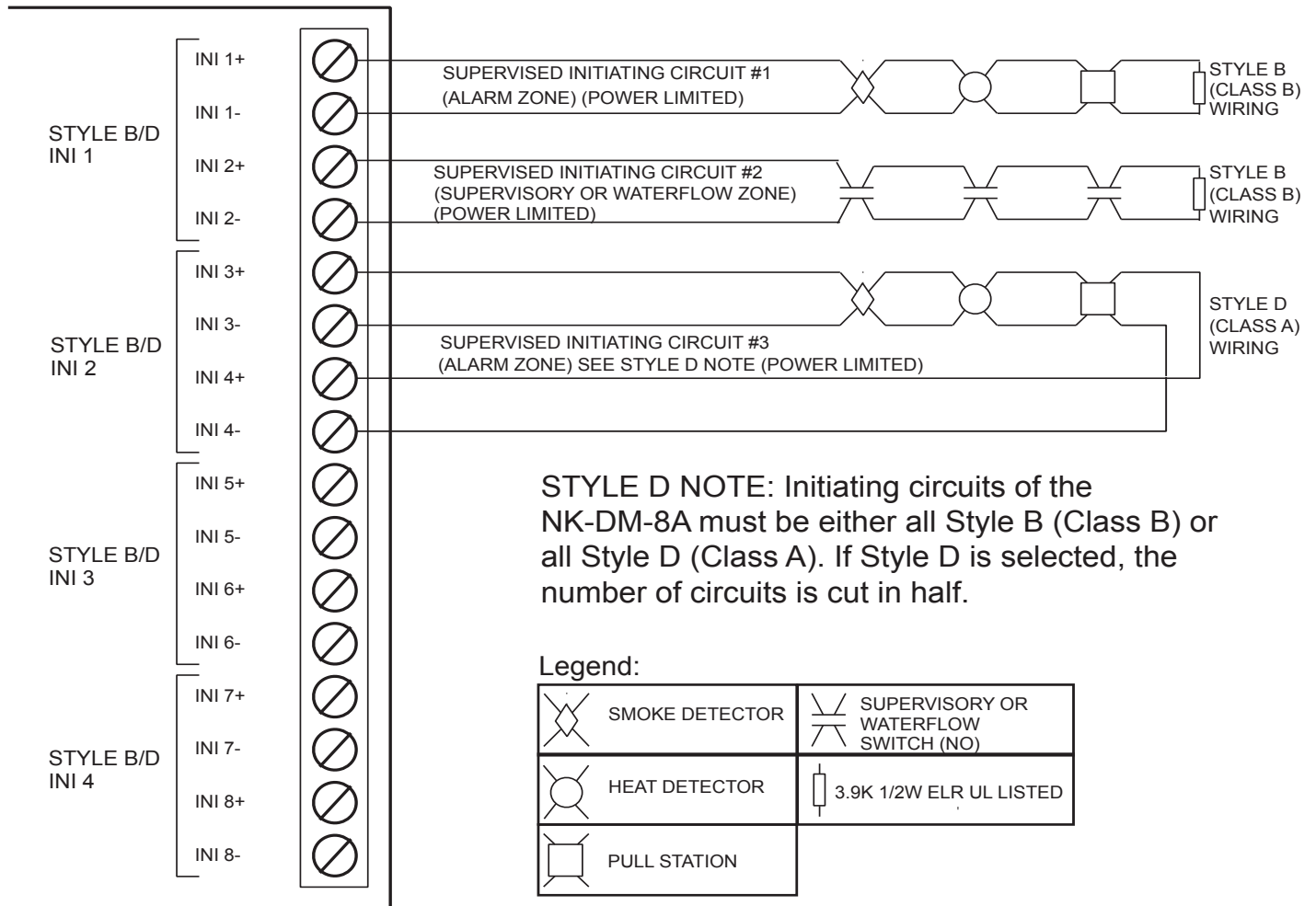

**Note:**

- Terminal blocks are “depluggable” for ease of wiring.
- All power limited circuits must use type FPL, FPLR, or FPLP power limited cable.
- Initiating circuits are fully supervised and rated for 22 VDC, 3 mA standby, 5 mV ripple, 50 mA max alarm. They may be configured as required. The alarm threshold is 21 mA. Maximum loop resistance is 100 ohms, 50 ohms per side.
- All conventional hardwire initiating circuits are Compatibility ID "A".



## Signal Module (SGM-1004A) Terminal Connections

Wire devices to terminals as shown in Figure 36 below. See Appendix A for signal module specifications, and LT-1023 for compatible devices.

**Figure 36: Hardwire Signal Module Terminal Connections**

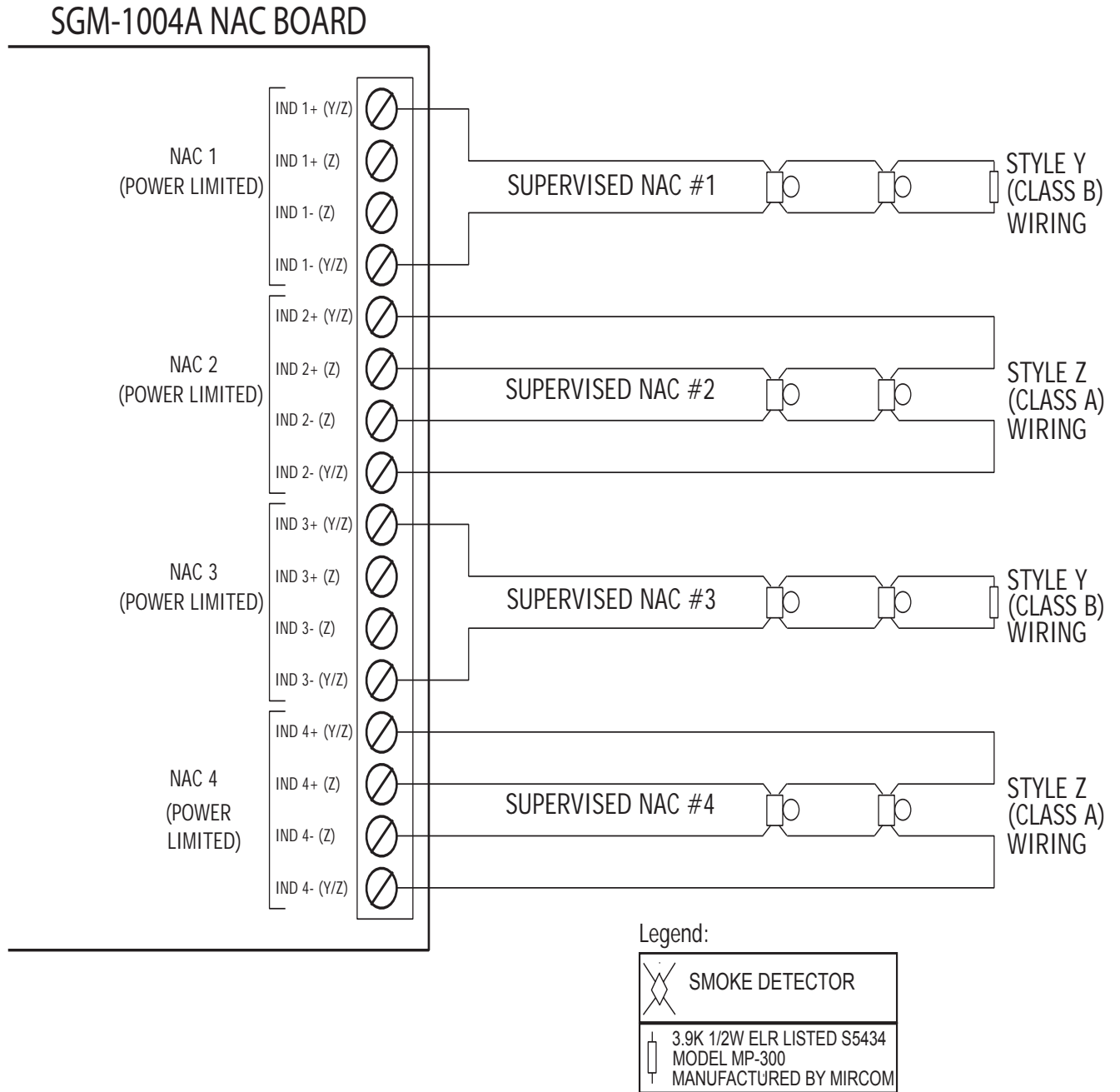

**Notes:**

- The terminal blocks are “depluggable” for ease of wiring.
- All power limited circuits must use type FPL, FPLR, or FPLP power limited cable.
- SGM-1004A NACs are fully supervised and rated for 24 VDC special application, 1.7A max. They must be wired as shown in the Wiring Tables and Information on page 58.

## Relay Module (RM-1008(A)) Terminal Connections

Relays are available as shown below.

**Figure 37: Hardwire Relay Module Terminal Connections**

### RM-1008A Relay Module

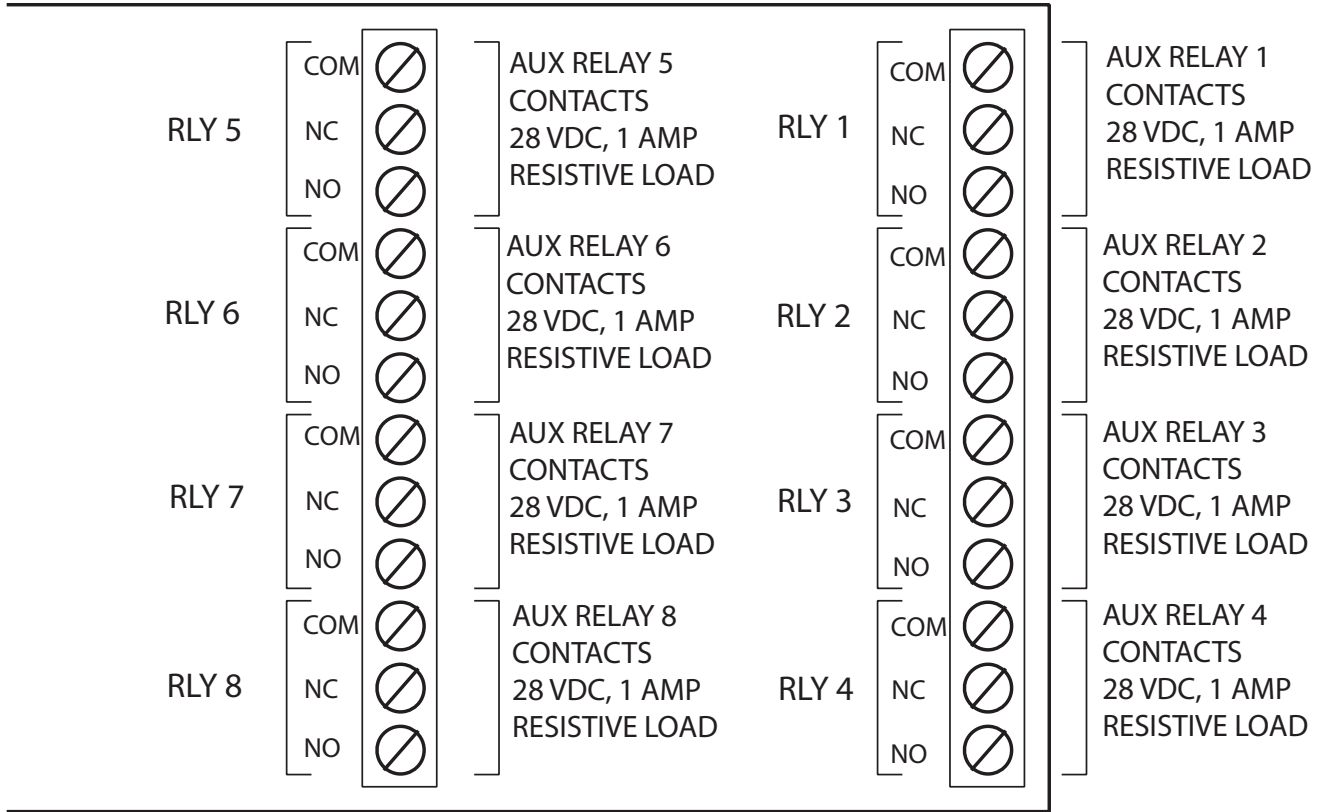

**Notes:**

- All relay circuits are power limited and must use type FPL, FPLR, or FPLP power limited cable.
- All relay circuits must be connected to a listed power limited source of supply.



**ATTENTION:**

- Do not connect 120 VAC directly to these relays.

## Polarity Reversal and City Tie Module (PR-300) Wiring

Wire PR-300 Polarity Reversal and City Tie Module (if used) as shown in Figure 38 below. Power Limited cable type FPL, FPLR or FPLP must be used.

For USA installation, the installer must use **Atlantic Scientific (Tel: 407-725-8000), Model #24544 Protective Device**, or similar **UL-Listed QVRG secondary protector**, as shown.

For use in Canada, the Protective Device is not required but still recommended.

**Figure 38: Polarity reversal and city tie module terminal connection**

### PR-300

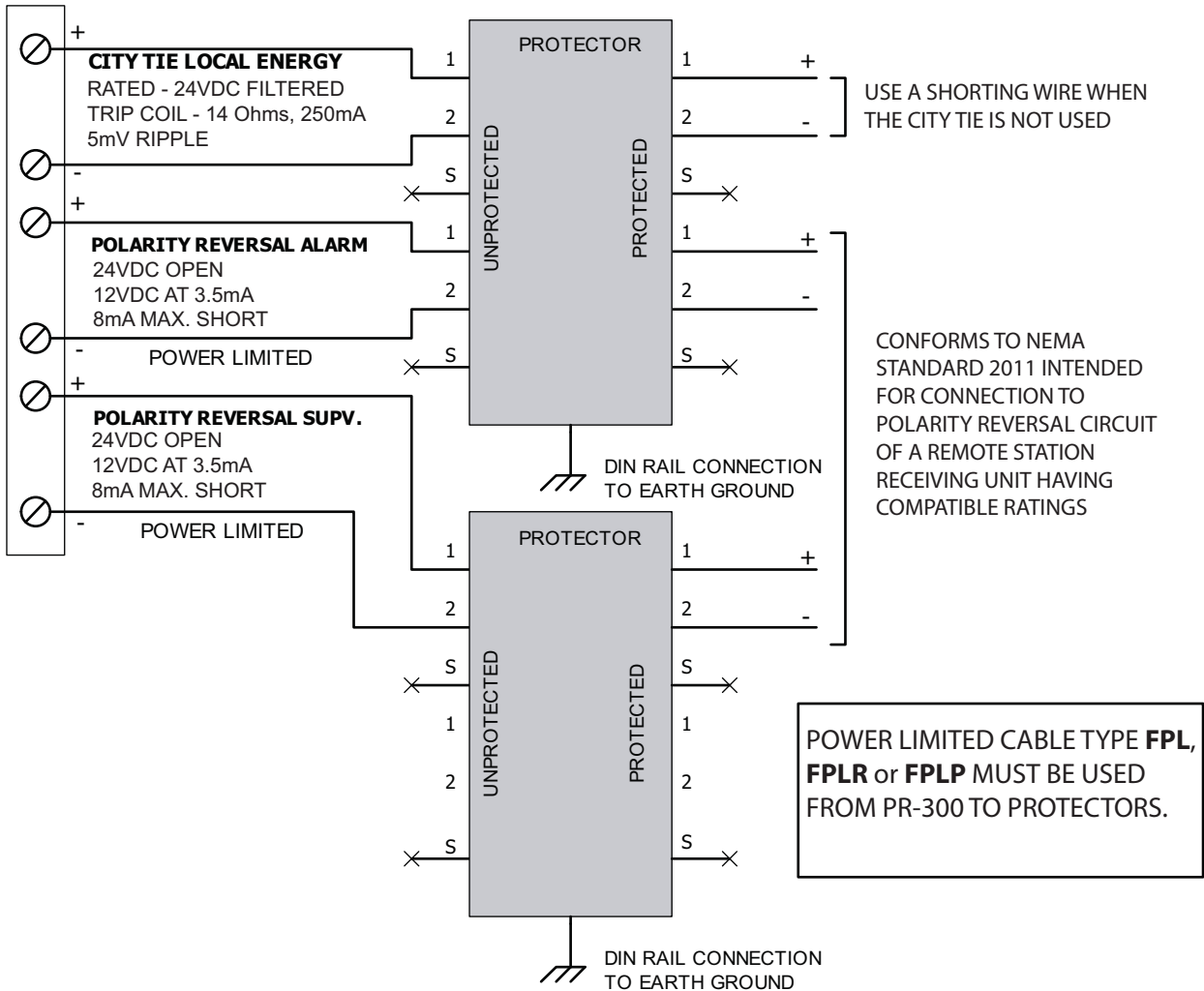

**Notes:**

- Either the PR-300's city tie or polarity reversal interface may be used, but not both.
- The city tie interface is not power limited.
- Plug PR-300 ribbon cable (P1) into connector (P4) of the FX-2000N main fire alarm module.
- Cut jumper (JW1) on the PR-300 module in order to transmit a trouble condition to the monitoring station.
- Remove jumper plug from jumper JW4 on the main fire alarm module.
- The polarity reversal interface is power limited and must use type FPL, FPLR, or FPLP power limited cable.
- For polarity reversal operation, short the city tie connection.

### UDACT-300A Main Board Terminal Connections

Wire the two telephone lines to RJ31X Connector terminals as shown in Figure 39 below. The UDACT-300A terminals are located on the top left hand corner of the board. If using a cellular or wireless service, use the Line 2 interface connection only.



**Note: Most Authorities Having Jurisdiction (AHJ) do not allow the connection of premise telephones, see specifications for more information.**

**Figure 39: Telephone Line Wiring Diagram**

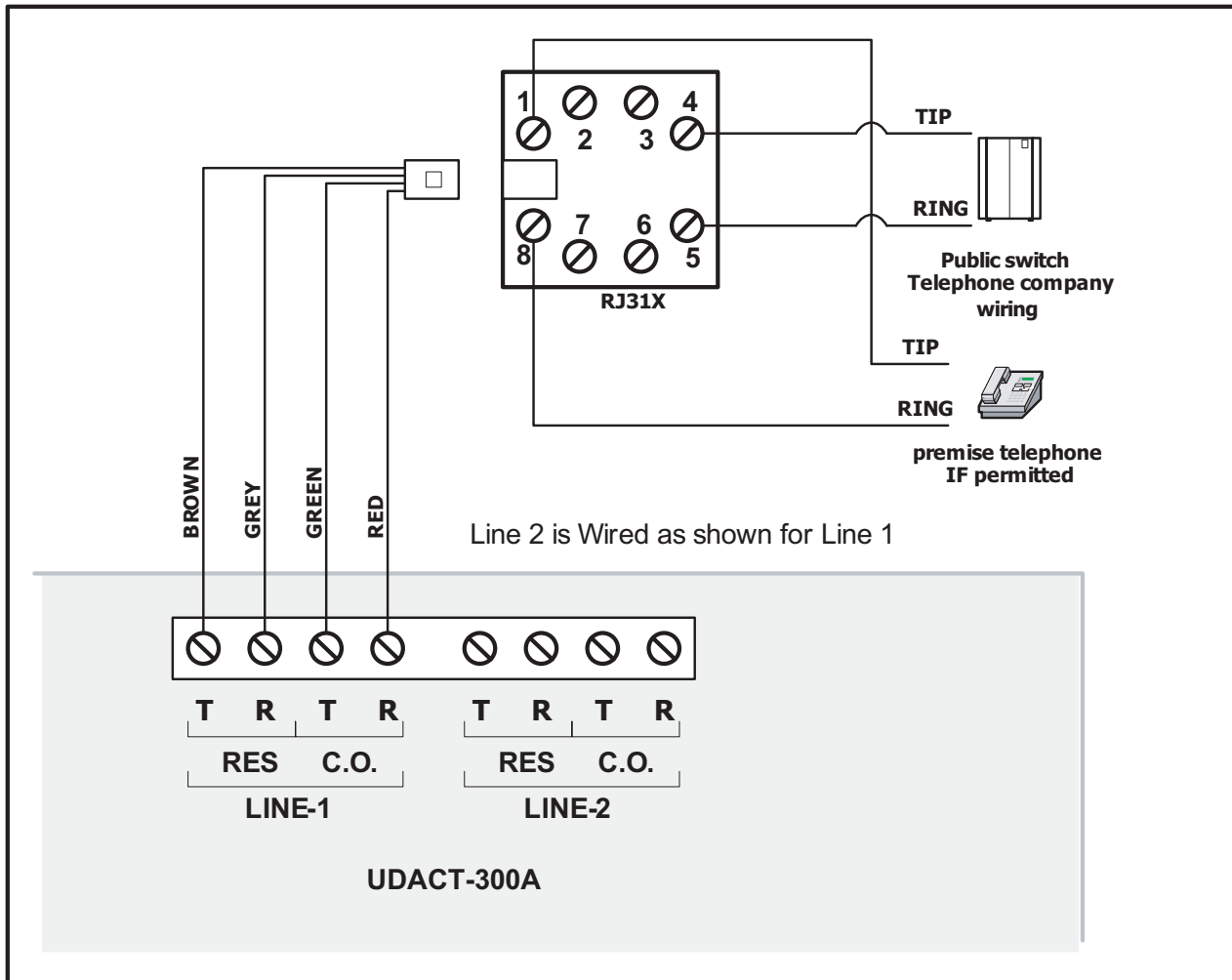

## Power Supply Connections

The power supply is part of the main chassis. The ratings are outlined in the table below.

| Model   | Electrical Input Ratings   | Power Supply Total Current | Battery Fuse on Main Module                   |
|---|--|----------------------------|---|
| FX-2003-12NDS, FX-2003-12NXTDS & FX-2017-12NDS Main Chassis | 120 VAC, 60 Hz, 4A / 240VAC, 50hz, 2A  | 12 amps maximum            | 20 Amp, 1-1/4" Slow Blow Non-replaceable Fuse |
| FX-2009-12NDS Main Chassis                                  | 120 VAC, 60 Hz, 4A / 240VAC, 50hz, 2A  | 12 amps maximum            | 20 Amp, 1-1/4" Slow Blow Non-replaceable Fuse |
| All Chassis'  | IN-LINE 20 Amp, 1 1/4" Fast Acting Fuse, positive side of Battery Connection |                            |   |

See Appendix A for more power supply specifications. Wire as shown below with proper gauge wire.

**Figure 40: Power Supply Connections**

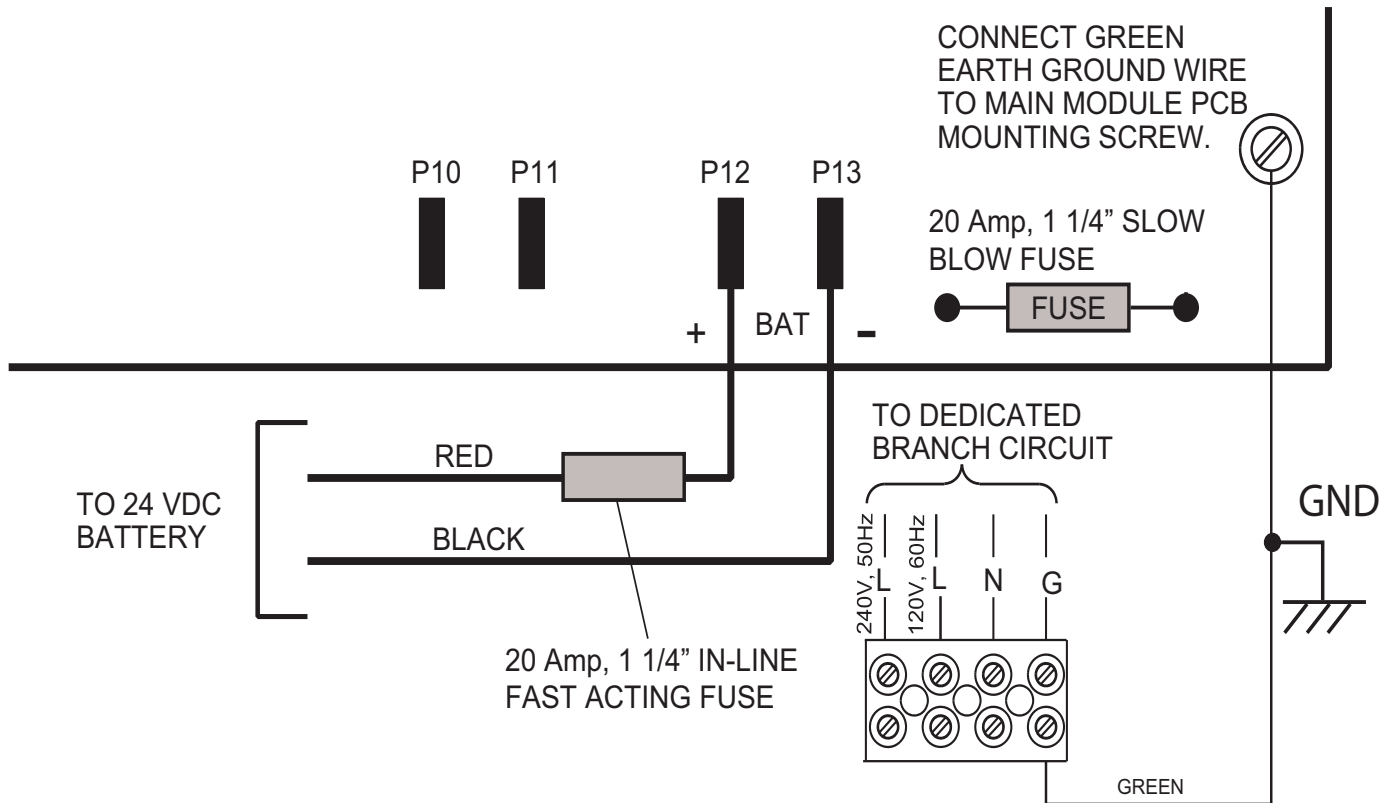

**CAUTION:**

- To prevent sparking, connect batteries after the system's main A.C. power is turned ON.
- **Do not exceed power supply ratings.**
- **Adhere to voltage markings as specified on labels.**

## Wiring Tables and Information

Table 9: Wiring Table for Initiating Circuits.

| Wire Gauge<br>(AWG) | Maximum Wiring Run to Last Device (ELR) |      |
|---------------------|---|------|
|                     | ft.                                     | m    |
| 22                  | 2990                                    | 910  |
| 20                  | 4760                                    | 1450 |
| 18                  | 7560                                    | 2300 |
| 16                  | 12000                                   | 3600 |
| 14                  | 19000                                   | 5800 |
| 12                  | 30400                                   | 9200 |



**Note:** Maximum loop resistance should not exceed 100 Ohms.

Table 10: Wiring Table for NACs

Main board NACs are rated for 1.7 amps each. The SGM-1004A NACs are rated for 1.7 amps each.

| Total Signal Load<br>Amperes | Maximum Wiring Run to Last Device (ELR) |     |       |      |       |      |       |      | Max Loop Resistance<br>Ohms |
|------------------------------|---|-----|-------|------|-------|------|-------|------|-----------------------------|
|                              | 18AWG                                   |     | 16AWG |      | 14AWG |      | 12AWG |      |                             |
|                              | ft.                                     | m   | ft.   | m    | ft.   | m    | ft.   | m    |                             |
| 0.06                         | 2350                                    | 716 | 3750  | 1143 | 6000  | 1829 | 8500  | 2591 | 30                          |
| 0.12                         | 1180                                    | 360 | 1850  | 567  | 3000  | 915  | 4250  | 1296 | 15                          |
| 0.30                         | 470                                     | 143 | 750   | 229  | 1200  | 366  | 1900  | 579  | 6                           |
| 0.60                         | 235                                     | 71  | 375   | 114  | 600   | 183  | 850   | 259  | 3                           |
| 0.90                         | 156                                     | 47  | 250   | 76   | 400   | 122  | 570   | 174  | 2                           |
| 1.20                         | 118                                     | 36  | 185   | 56   | 300   | 91   | 425   | 129  | 1.5                         |
| 1.50                         | 94                                      | 29  | 150   | 46   | 240   | 73   | 343   | 105  | 1.2                         |
| 1.7                          | 78                                      | 24  | 125   | 38   | 200   | 61   | 285   | 87   | 1.0                         |



**Note:** Maximum voltage drop should not exceed 1.8 volts.

**Table 11: Analog Loop Wiring**

| Wire Gauge (use twisted pair) | Loop Total (Out and In) Maximum Twisted Pair Wire Run |      |
|-------------------------------|---|------|
|                               | (AWG)   | ft.  |
| 12                            | 10,000  | 3049 |
| 14                            | 7971  | 2429 |
| 16                            | 4980  | 1518 |
| 18                            | 3132  | 955  |

**Note:**

- Line capacitance shall not exceed 0.5 mF.
- Inductance shall not exceed 1 mH.
- Resistance shall not exceed 40 ohms.

**Power Wiring:** Use Table 10: Wiring Table for NACs on the previous page to see the wiring information for the remote annunciator being used.

**RS-485 Wiring:** See the wiring information for the remote annunciator being used.

**4-Wire Smoke Wiring:** The maximum allowable current is 0.2 amperes. The maximum allowed voltage drop is 1 volt. Refer to Table 10: Wiring for NACs on the previous page.

**Shield for Analog Loop Wiring:** Only twisted pair is recommended, but if shielded twisted pair is used, wire shield at the start and the end of the loop to the terminals marked Shield at the loop adder board.

# System Checkout

## Before Turning the Power On

1. To prevent sparking, *do not* connect the batteries. Connect the batteries after powering the system from the main AC supply.
2. Check that all modules are installed in the proper location with the proper connections.
3. Check all field (external) wiring for opens, shorts, and ground.
4. Check that all interconnection cables are secure, and that all connectors are plugged in properly.
5. Check all jumpers and switches for proper setting.
6. Check the AC power wiring for proper connection.
7. Check that the chassis is connected to EARTH GROUND (cold water pipe). Refer to NFPA 70.
8. Make sure to *close the front cover plate* before powering the system from main AC supply.



**Note:** When using Class A and isolators on an addressable loop, configure system as Class B, wire loop as Class A, except do not connect the last device back to the panel. Do a system checkout. Then connect the return of the Class A circuit and configure as Class A.

## Power-Up Procedure

1. After completing the above procedures, power up the panel (AC only). The green AC On LED and the Common Trouble LED should illuminate, and the buzzer should sound.
2. Press the System Reset button. Since the batteries are not connected, the Battery Trouble LED should illuminate, the trouble buzzer should sound intermittently, and the Common Trouble LED should flash.
3. Connect the batteries while observing correct polarity: the red wire is positive (+) and the black wire is negative (-). All indicators should extinguish except for the AC On LED and the LCD should show a normal status condition.
4. Auto-Configure or PC Configure the fire alarm control panel as described in the Configurator Guide.

## Troubleshooting

| Message         | Description  |
|-----------------|--|
| Circuit Trouble | Normally when a circuit trouble occurs, its designated trouble indicator will be illuminated, as well as the Common Trouble indicator and Trouble buzzer. To correct the fault, check for open wiring on that particular circuit loop or see if the circuit disconnect switch is in the ON or CLOSED position. <i>Note: disconnecting a circuit will cause a system trouble (off-normal position).</i> |
| Ground Fault    | The FX-2000N panel has a Common Ground Fault Detector. To correct the fault, check for any external wiring touching the chassis or other earth ground connection.  |
| Battery Trouble | Check for the presence of batteries and their condition. Low voltage (below 20.4V) will cause a battery trouble. If battery trouble condition persists, replace the batteries as soon as possible.   |



# Indicators, Controls, and Operation

Refer to Figure 41 below for LED indicators, control buttons, and switches locations.

**Figure 41: Indicators and Control Location**

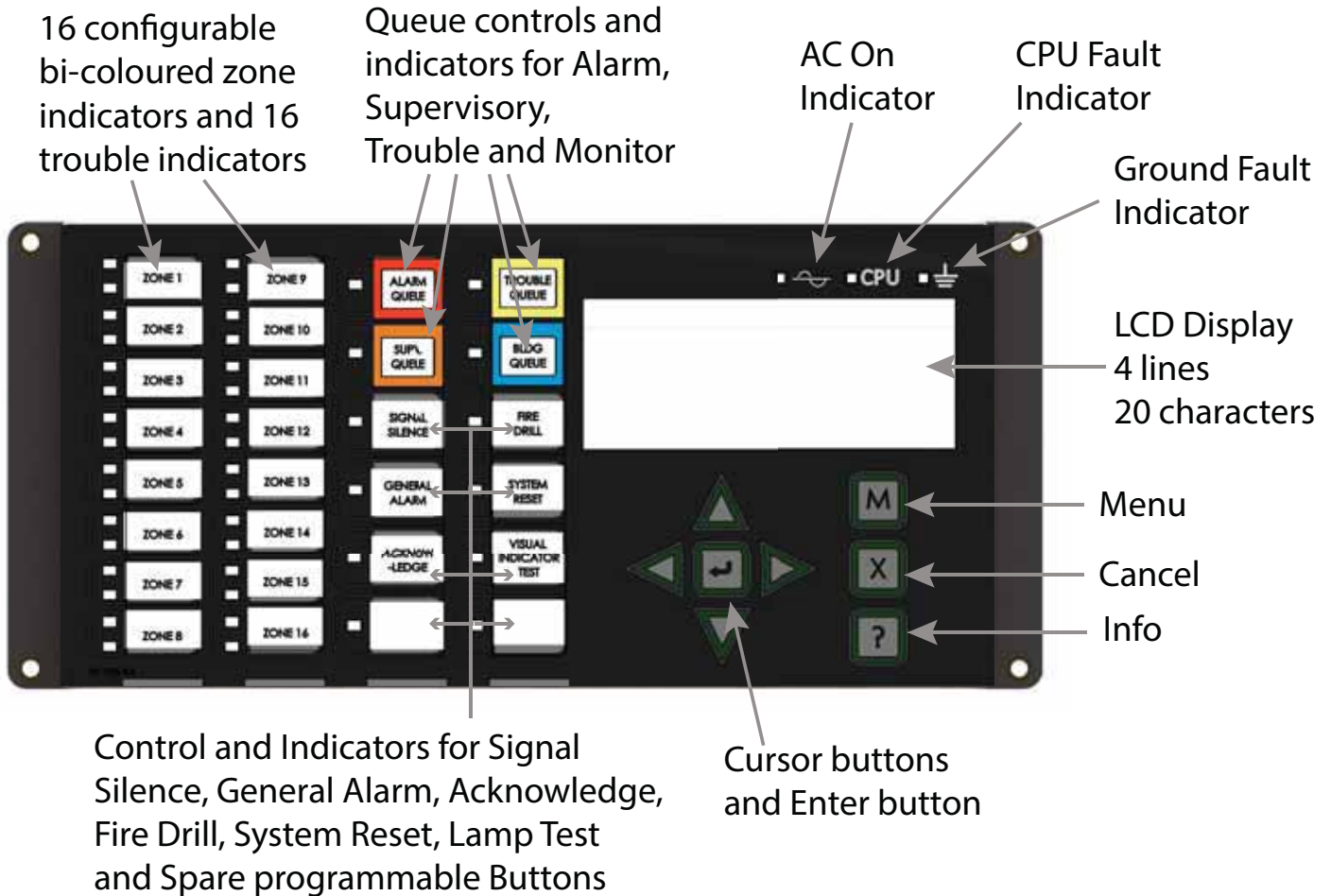

LED indicators are amber (trouble or supervisory), red (alarm), or green (AC On), and may illuminate continuously (steady) or at one of two flash rates:

- **Fast Flash:** 120 flashes per minute, 50% duty cycle
- **Trouble Flash:** 20 flashes per minute, 50% duty cycle



**Note:** The General Alarm LED and pushbutton, and the Acknowledge LED and pushbutton, are active only on a system configured for “Two Stage.”

## Paper Labels for Buttons and Indicators

Buttons and indicators are supplied with paper labels. These labels slide into the plastic label templates on the face of the panel. Paper labels allow for easy English / French selection and custom-printed zone information.

## Common Indicators

| Indicators            | Description  |
|-----------------------|--|
| Buzzer                | <p>The Buzzer is activated by any of the following</p> <ul style="list-style-type: none"> <li>Fire Alarm - Steady</li> <li>Supervisory Alarm - Fast Rate</li> <li>Trouble - Trouble Rate</li> <li>Monitor - Configurable to sound at Trouble Rate</li> </ul> <p>If the Buzzer is turned on in response to a Non-Latching Trouble or Supervisory, it will be turned off if the condition causing it goes away and there is no other reason for it to be on.</p>   |
| AC On LED             | <p>The AC On Indicator is activated steady green while the main AC power is within acceptable levels. It is turned off when the level falls below the power-fail threshold and the panel is switched to standby (battery) power.</p>   |
| Alarm Queue LED       | <p>The Common Alarm LED flashes red whenever the Panel is in Alarm. An alarm results from any alarm on any point or input programmed as Alarm or activation of the manual red General Alarm Button (if the Panel is set for Two Stage Operation). The Alarm Queue LED will go steady, once all alarms in the queue have been reviewed using the Alarm Queue button. Since all Alarms are latched until the Panel is reset, the Common Alarm LED will remain on until then.</p>   |
| Supervisory Queue LED | <p>The Common Supv. (Supervisory) LED flashes amber at the Fast Flash Rate when there is a Supervisory Alarm in the Panel, as the result of any Latching or Non-Latching Supervisory Circuit. The LED turns off if all Non-Latching Supervisory Circuits are restored and there are no Latching Supervisory Circuits active. The Supv. Queue LED will go steady, once all supervisory alarms in the supervisory queue have been reviewed using the Supv. Queue button. Latching Supervisory Alarms remain active until the Panel is reset.</p> |
| Trouble Queue LED     | <p>The Common Trouble LED flashes amber at the Trouble Flash Rate when there is any Trouble condition being detected on the panel. It is turned off when all Non-Latching Troubles are cleared. The Trouble Queue LED will go steady, once all troubles in the trouble queue have been reviewed using the Trouble Queue button.</p>  |
| Monitor Queue LED     | <p>The Monitor Trouble Indicator flashes amber at the Trouble Flash Rate when there is any Monitor condition being detected on the panel. It is turned off when all Monitors are cleared.</p>  |
| CPU Fault LED         | <p>The CPU Fault Indicator is flashed yellow at the Trouble Flash Rate if the CPU is faulty.</p>   |
| Fire Drill LED        | <p>The Fire Drill Indicator turns on steady amber while Fire Drill is active.</p>  |
| Acknowledge LED       | <p>If the Panel is configured as Two Stage, the Acknowledge Indicator flashes amber at the Fast Flash Rate while the Auto General Alarm Timer is timing out. It turns on steady amber when that Timer is cancelled by activating the Acknowledge or Signal Silence buttons. If the Auto General Alarm Timer times-out and puts the Panel into General Alarm, the Indicator is turned off.</p>  |
| General Alarm LED     | <p>In Two Stage Operation only, the General Alarm Indicator is activated steady red when General Alarm is activated due to the red General Alarm button being pushed, a General Alarm Initiating Circuit being activated, or the Auto General Alarm Timer timing out. Once the General Alarm Indicator has been turned on it will stay active until the Panel is reset.</p>  |
| Signal Silence LED    | <p>The Signal Silence indicator is flashed amber, at the trouble rate when Indication Circuits are Silenced either by the Signal Silence button, or by the Auto Signal Silence Timer. It is turned off when the Signals are re-sounded by a subsequent Alarm.</p>  |
| Ground Fault LED      | <p>The Ground Fault Indicator flashes amber at the Trouble Rate when the Ground Fault Detector detects a Ground Fault on any field wiring. It turns off immediately when the Ground Fault is cleared.</p>  |









## Common Controls

### LCD Display:

The display is a large 4 line by 20 character back-lit alphanumeric LCD. It displays information on the panel and its devices. There are cursor buttons for menu selection and control. Information provided by the LCD display is an alarm log, an event log, current levels, device information, verification and maintenance reports.

### Queue Buttons

Use the queue buttons to select a particular queue to review.

- Use the **Alarm Queue** button to view all alarms. Pressing this button will show the latest alarm on the LCD display. Use  and  to view all previous alarms.
- Use the **Supervisory Queue** button to view all supervisory conditions. Pressing this button will show the latest supervisory information on the LCD display. Use  and  to view all previous supervisory conditions on the LCD display.
- Use the **Trouble Queue** button to view all trouble conditions. Pressing this button will show the latest trouble condition on the LCD display. Use  and  to view any previous troubles.
- Use the **Monitor Queue Button** to show all monitor conditions. Pressing this button will show the latest monitor information on the LCD display. Use  and  to view all queued monitor conditions.

Queues are displayed on the screen according to a priority sequence. Queue priority ranking from highest to lowest is as follows: alarm, supervisory, trouble, and monitor. If, for example, you are viewing a monitor queue and an alarm occurs, the display will immediately display the alarm condition. Also, if there is no activity on the system for 10 seconds after you have pressed a queue button, the display will switch to the highest priority condition.

### Cursor Buttons

These four buttons around the Enter Button are used for up (previous), down (latest), left, and right selection of items on the LCD Display.

### Enter Button

This button is used to select a displayed item on the LCD Display.

### Cancel Button

This button is used to cancel an operation.

### Menu Button

This button is used to initiate the FX-2000N Menu System.

### Info Button

This button is used to get more details about a displayed item.

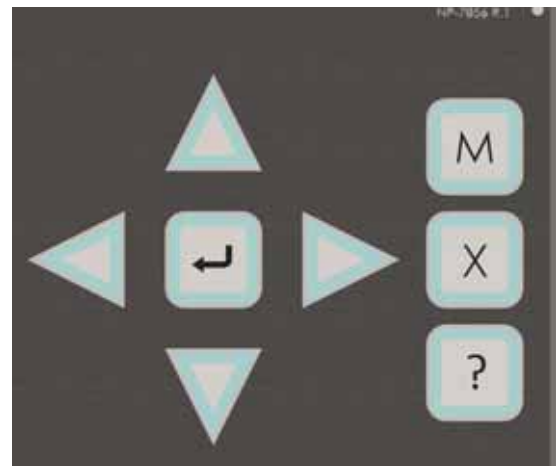

### **System Reset Button**

The System Reset button causes the Fire Alarm Control Panel, and all Circuits, to be reset

- Resets all Latching, Trouble Conditions
- Resets all Initiating Circuits
- Resets 4-Wire Smoke Supply and Aux. Power Supply
- Turns off all NACs
- Turns off Signal Silence, Ack & GA Indicators
- Turns off Fire Drill
- Stops and resets all Timers
- Processes inputs as new events
- Aux Disconnect is not affected
- Reset cannot be activated until the Signal Silence Inhibit timer has expired.

### **Signal Silence Button**

Activation of the Signal Silence button when the Panel is in Alarm, turns on the Signal Silence Indicator and deactivates any Silenceable NACs. Non-Silenceable Circuits are unaffected. Signals will re-sound upon any subsequent Alarm. This button does not function during any configured Signal Silence Inhibit Timer period. It also does not function if the NACs are active as the result of a Fire Drill. In a Two Stage System, if the Auto General Alarm Timer has timed out, this Signal Silence button also performs the same function as the Acknowledge button.

### **Fire Drill Button**

The Fire Drill button activates all programmed and non-Disconnected NACs, but does not transmit any Alarms via the City Tie, or Common Alarm Relay. Fire Drill may be programmed to operate specific NACs. Fire Drill is cancelled by pressing the button again (toggle switch), or if the Panel goes into a real Alarm.

### **Acknowledge Button (Two Stage Only)**

If the Panel is not configured for Two Stage Operation, this button does nothing. If the Panel is configured for Two Stage Operation, activation of the Acknowledge button while the Auto General Alarm Timer is timing (there is an Alarm in the Panel, but it is still in the First Stage), that timer is cancelled, and the Acknowledge Indicator is on steady amber.

### **General Alarm Button (Two Stage Only)**

If the Panel is not configured for Two Stage Operation, this button does nothing. If the Panel is configured for Two Stage Operation, activation of the General Alarm button immediately sends the Panel into Second Stage - General Alarm. It will also re-activate the Signals if they have been Silenced during General Alarm. The General Alarm condition remains active until the Panel is reset.

### **Lamp Test Button**

Activation of the Lamp Test button turns all front panel Indicators on steady in whichever colour they would normally be activated and turns the buzzer on steady. If Lamp Test is active for more than 10 seconds, Common Trouble is activated.

## Single Stage Operation

In a single stage system, all alarm inputs are treated in a similar manner. Alarm inputs include any of the following: non-verified alarm, verified alarm, sprinkler alarm, water-flow alarm, and general alarm circuits. Any of these alarm inputs occurring when the panel is not already in alarm cause the following:

- The buzzer sounds steadily
- If fire drill is active, it is cancelled
- The Common Alarm LED turns on
- The Common Alarm relay activates if Aux disconnect is not active
- The Auto Signal Silence timer, if configured, starts
- The Signal Silence Inhibit timer, if configured, starts
- All non-disconnected NACs programmed to the input are activated provided that Aux disconnect is not active
- Non-disconnected strobes associated with the input are activated
- Non-disconnected signals associated with the input are activated at the evacuation rate

Subsequent alarms when the panel is already in alarm, cause the following:

- The alert buzzer sounds steadily
- If Signals have been silenced, they are resounded, the Signal Silence LED turns off, and the Auto Signal Silence timer, if configured, is restarted
- Any additional non-disconnected strobes associated with the input are activated continuously
- Any additional non-disconnected signals associated with the new input are activated at the evacuation rate

## Two Stage Operation

In a two stage system, alarm inputs are either first stage (alert) inputs or second stage (general alarm) inputs. First stage inputs include inputs from the following types of circuits: non-verified alarm, verified alarm, sprinkler alarm, and water-flow alarm. Second stage inputs include alarms on the general alarm circuits, activation of the General Alarm button, or expiration of the Auto General Alarm timer. Any of these alarm inputs occurring when the panel is not already in alarm cause the following:

- The buzzer sounds steadily
- If fire drill is active, it is cancelled
- The Common Alarm LED turns on
- The Common Alarm relay activates if Aux disconnect is not active
- The Auto Signal Silence timer, if configured, starts
- The Signal Silence Inhibit timer, if configured, starts
- All Non-disconnected indicating programmed to the input are activated provided that Aux disconnect is not active

If the alarm is a second stage alarm,

- All non-disconnected strobe circuits are activated continuously
- All non-disconnected signal circuits are activated at the evacuation rate
- The General Alarm LED turns on.

If the alarm is a First Stage alarm,

- Non-disconnected strobe circuits programmed to that circuit are activated continuously
- Non-disconnected signal circuits programmed to that circuit are activated with the alert code
- The Auto General Alarm timer, if configured, starts
- The Acknowledge LED starts flashing.

Subsequent First Stage alarms when the panel is already in alarm, cause the following:

- The buzzer sounds steadily
- If signals have been silenced as a result of the silence button or the Auto signal silence timer, signals are resounded as they were before signal silence, the Signal Silence LED turns off, and the Auto Signal Silence timer, if configured, is restarted
- If the panel is not already in General Alarm, additional non-disconnected signals programmed to the new input are activated with the Alert Code (see *Indicating (Signal) Circuit Types* section).
- If the panel is not already in General Alarm and if the Acknowledge LED is on steady indicating that the Auto General Alarm timer has been Acknowledged the timer is restarted and the Acknowledge LED is extinguished.

A second stage alarm (general alarm) when the panel is already in alarm causes the following:

- The buzzer sounds steadily
- All non-disconnected signals are activated at the evacuation rate
- If the Signal Silence LED is on, it turns off and the Auto Signal Silence timer, if configured, is restarted
- The Acknowledge LED if on, turns off

Alarm inputs are latching: they remain active until system reset.



**Note:** If the system is configured for correlations, any second stage / general alarm condition activates all NACs whether they are correlated or not.

## Pre-Signal Operation

To configure the panel for pre-signal, all alarm inputs must be correlated to one NAC circuit that is wired to a Notification Appliance in the Control Room that is constantly monitored by an Operator. Using the FX-2000N Configurator, “Subsequent Alarm” in “Common System Status” must be correlated to turn on the Remaining NAC circuits in the system. To confirm the alarm (i.e. subsequent alarm) the operator can press the “General Alarm” button on the panel or activate a Manual Station in the Control Room.



**Note:** Pre-Signal is not permitted to be used in Canada, unless approved by the AHJ.

## Circuit Types

The term **circuits** refers to an actual electrical interface, either initiating (detection) or indicating (signal). The term **zone** is a logical concept for a fire alarm protected area, and will consist of at least one circuit. Often the terms zone and circuit are used interchangeably, but in this manual the term circuit is used.

### Initiating (Detection) Circuit Type

| Initiating (Detection) Circuit Type | Description   |
|-------------------------------------|---|
| Non-Verified Alarm                  | This is a "normal" type of alarm which may have pull stations, smoke detectors, or heat detectors attached. Any activation of these devices will immediately result in an alarm condition in the fire alarm control panel. An alarm condition causes the associated circuit Status LED and the Common Alarm LED to illuminate red.  |
| Verified Alarm                      | These alarms are verified by a reset and timing procedure, and may have Manual Stations, smoke detectors attached. Any activation of Manual Stations will result in an alarm condition in the fire alarm control panel within four seconds. Smoke detectors will be verified for a real alarm within 60 seconds depending upon the start-up time of the smoke detectors being used. If four seconds is too long a response time for pull stations, then they should be wired separately on a non-verified alarm circuit. An alarm condition causes the associated circuit Status LED and the Common Alarm LED to illuminate red. Verified Alarm is not permitted for heat detectors, 4-wire smoke detectors and smoke detectors with built-in alarm verification. Refer to Appendix D Alarm Verification for details. |
| Water-Flow Alarm                    | An alarm for water-flow sensors. These alarms are identical to normal non-verified alarms except that any NACs programmed to these circuits (all are by default) are non-silenceable. Also, if water-flow retard operation is enabled, then these circuits are sampled every one second; if ten samples are active within any 15 second interval, the water-flow alarm is confirmed and processed. An alarm condition causes the associated circuit Status LED and the Common Alarm LED to illuminate red.<br><b>Note: Do not use the retard operation with any external retarding device; maximum retard may not exceed 120 seconds.</b>   |
| Sprinkler Alarm                     | An alarm for sprinkler flow sensors. These alarms are identical to normal non-verified alarms unless the water-flow retard operation is enabled. If water-flow retard operation is enabled, then these circuits are sampled every one second; if ten samples are active within any 15 second interval, the sprinkler alarm is confirmed and processed. An alarm condition causes the associated circuit Status LED and the Common Alarm LED to illuminate red.<br><b>Note: Do not use the retard operation with any external retarding device; maximum retard may not exceed 120 seconds.</b>   |
| General Alarm                       | These alarms provide remote general alarm such as for remote key switches. In a two stage system, these inputs perform exactly the same function as the front panel or remote annunciator general alarm button. In a single stage system, these inputs act the same as non-verified alarms, but if correlations are enabled, general alarm initiating circuits are correlated to <i>all</i> NACs.   |
| Non-Latching Supervisory            | These alarms are for supervisory devices. An activation on these circuits will cause the Circuit Status LED and the Common Supervisory LED to illuminate amber. The buzzer will sound continuously. If the circuit activation is removed, the supervisory condition will clear (so long as there are no other supervisory conditions in the system) and the circuit Status LED will extinguish.   |
| Latching Supervisory                | These alarms are for supervisory devices. An activation on these circuits will cause the Circuit Status LED and the Common Supervisory LED to illuminate amber. The buzzer will sound continuously. If the circuit activation is removed, the Supervisory condition will <i>not</i> clear.  |

| Initiating (Detection) Circuit Type | Description   |
|-------------------------------------|---|
| Monitor                             | This is a supervised general purpose non-latching input used mainly for correlating to a relay circuit. No other system condition occurs as a result of its activation (short-circuit), although it is supervised for trouble (open-circuit). |
| Trouble-Only                        | This circuit is used for monitoring a trouble condition from an external device such as a Mircom Series 500 Audio System. Both open and short circuits generate a non-latching trouble condition.   |

### Indicating (Signal) Circuits Types

| Indicating (Signal) Circuit Type | Description  |
|----------------------------------|--|
| Silenceable Signal               | For audible devices such as bells and piezo mini-horns that may be silenced either manually or automatically. While sounding, these follow the pattern appropriate for the condition: the configured evacuation code (default is temporal code) during single-stage alarm, or two stage general alarm, or the alert code during a two stage system's alert (first) stage.  |
| Non-Silenceable Signal           | For audible devices such as bells and piezo mini-horns that may not be silenced either manually or automatically. While sounding, these follow the pattern appropriate for the condition: the configured evacuation code (default is temporal code) during single-stage alarm, or two-stage general alarm, or the alert code during a two stage system's alert (first) stage.  |
| Coded Signal                     | For audible devices such as bells and piezo mini-horns that may be activated in code. The code consists of 4 digits with each digit consisting of 1-15 pulses on the signals. Each coded circuit can sound the complete code 1 to 15 times after which signals go silent or revert to programmed General Alarm rate.<br><b>Note: The NFPA-72 and ULC-S527 specify temporal tone. However, for retrofits of systems that were previously approved, coded signalling is allowed.</b> |
| Strobe                           | For visual devices such as strobes that use no code patterns (they are continuous).  |



**Evacuation Codes**

*Single stage codes*

- Continuous**            On 100% of the time
- Temporal Code**        3 of 0.5 second on, 0.5 second off then, 1.5 second pause
- March Code**            0.5 second on, 0.5 second off
- California Code**        5 seconds on, 10 seconds off

*Two-stage codes:*

- Alert Code**             0.5 second on, 2.5 seconds off
- General Alarm**        Evacuation code as selected from above.

**Figure 42: Evacuation Codes**

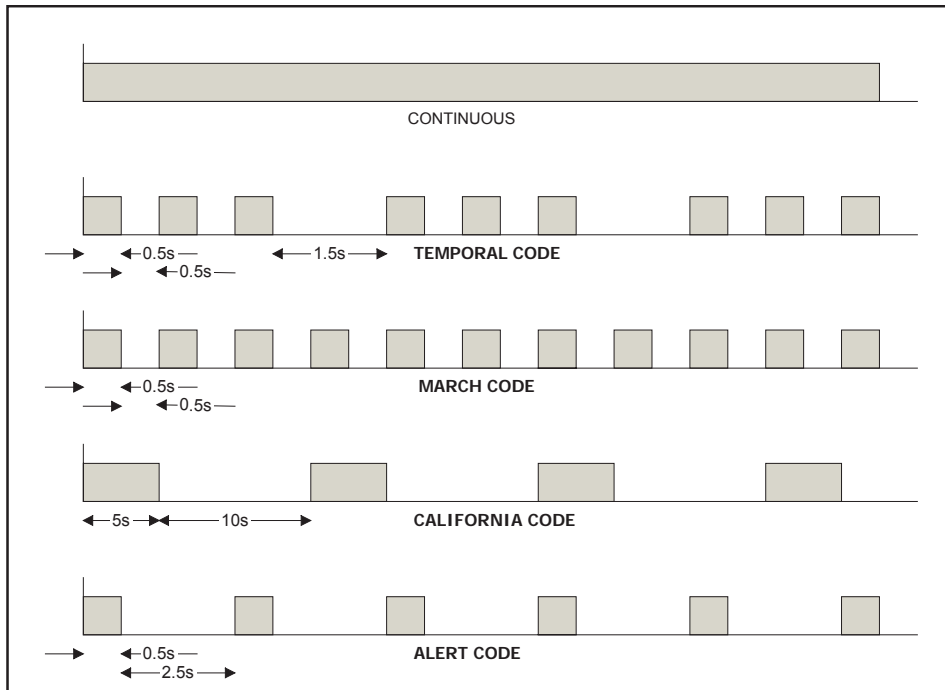

## Configuration

The FleX-Net™ network system which includes FX-2003-12N/DS, FX-2009-12N/DS, FX-2017-12N/DS, and FX-2000MNS is configured using Mircom software MSW-025.

### NOTICE TO USERS, INSTALLERS, AUTHORITIES HAVING JURISDICTION, AND OTHER INVOLVED PARTIES

This product incorporates field-programmable software. In order for the product to comply with the requirements in the Standard for Control Units and Accessories for Fire Alarm Systems, UL 864 and the Standard for Control Units for Fire Alarm Systems, CAN/ULC-527, certain programming features or options must be limited to specific values or not used at all as indicated below.

| Program feature or option                          | Permitted in UL 864, CAN/ULC-S527? (Y/N) | Possible settings   | Settings permitted in UL 864, CAN/ULC-S527 |
|--|--|---|--|
| Alarm Transmit Silence                             | No                                       | Enabled or Disabled   | Disabled or unchecked                      |
| COPTIR/A Detector Sensitivity Levels               | Yes                                      | Levels 1 through 6  | Levels 2 through 6                         |
| APB-200/COA Sounder base correlation to Fire input | Yes                                      | No sound (no correlation), Temporal-3, Temporal-4, March Code, Maintenance Chirp, Continuous Tone | Temporal-3                                 |
| APB-200/COA Sounder base correlation to CO input   | No                                       | No sound (no correlation), Temporal-3, Temporal-4, March Code, Maintenance Chirp, Continuous Tone | No Sound (no correlation)                  |

### Configuration Backup, Query and Fast-Forward

The panel supports previous, current and next configuration. The panel can be load configured without taking the panel off-line. Configuration reverts back to previous or moves to future configuration through front-panel menu.

### OPEN Graphic Navigator Software Package

This software package (OPEN GN) allows 3D graphic display of premises and devices. It provides unlimited floor plans and events, node and job support. It supports input file formats for floors such as: .svg, .dxf, .pdf, .png, .wmf, .jpeg. Device icons and state animations can be customized.

### Ethernet Port

Integrated TCP/IP Stack, Hardware based MAC address. Provides a fully configurable IP address. Use this Ethernet port to connect to OPEN graphics software. This port also provides web server for diagnostic and system report via LAN or WAN connection on-site or remotely.

### Boolean Logic Engine

Boolean logic functions are now available within the configuration software. Sophisticated logic functions such as: AND, OR, NOT, ANY n of m, >, <, >=, <>

Built-in timers or user configurable timers and intervals and schedules available to support UUKL operations.

### uBoot Based BootLoader

This program (inherent in the configuration) provides leading technology that allows a choice of multiple configuration files or firmware revisions to support site-specific requirements.

The FleXBoot™ shell offers UNIX style commands for directory listing, log download, diagnostic probing and system tuning and optimization.

# Typical FleX-Net™ System Layouts with Audio

The following figures show two typical applications for the FleX-Net™ system with audio.

Figure 43 below shows a typical FleX-Net™ system layout with the main lobby control panel as Node 1 and the combination Fire Alarm and Audio Network systems as Node 2 and 3. The diagram also shows addressable fire alarm loops, paging and telephone connections and audio cabinets.

**Figure 43: Typical FleX-Net™ System with Audio Nodes**

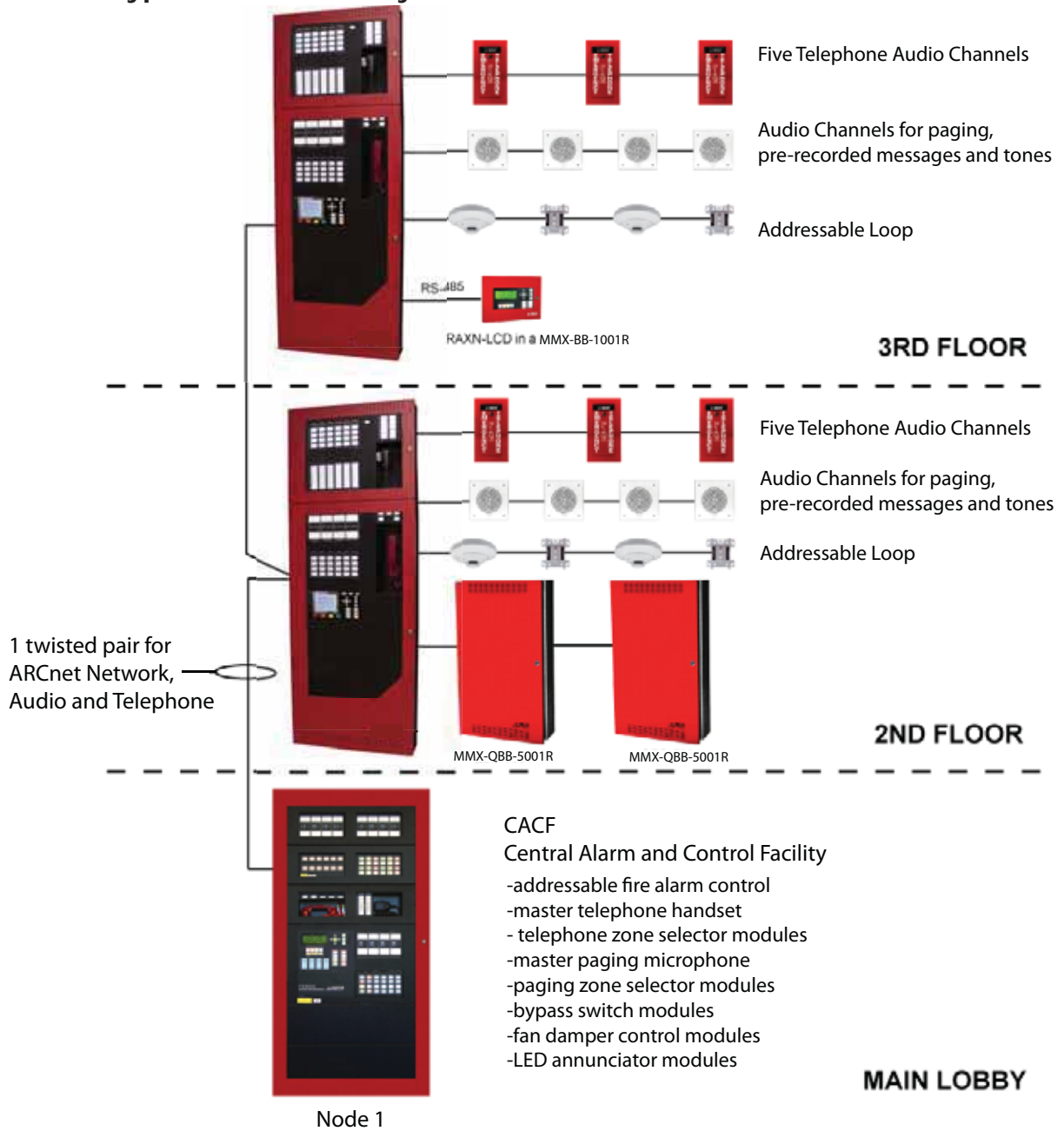
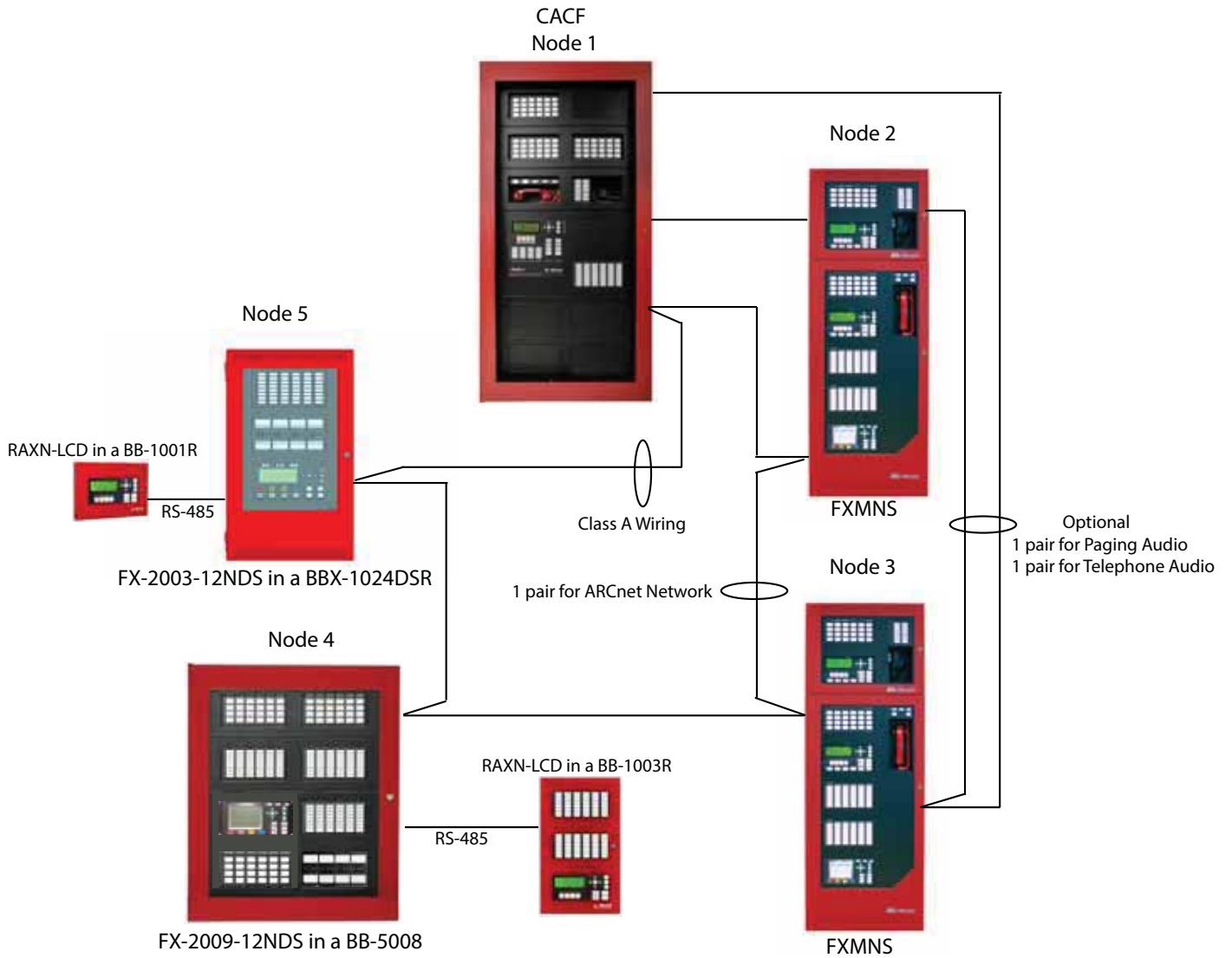

Figure 44 below shows the FleX-Net™ fire alarm and audio shown within the Integrated Network Fire/Audio cabinet as Node 2 and 3. Paging and telephone devices are hooked up to Nodes 2 and 3.

**Figure 44: Typical FX-2000N Network System with Audio and Non-Audio Nodes**





NOTE: Wiring for ARCnet Network, Audio and Telephone can be as shown (3 pairs) or 1 pair as shown in Figure 43

# System Components for the Integrated Fire/Audio Cabinet

## Network Fire Alarm

|   | Model      | Description   |
|---|------------|---|
|  | FX-2000MNS | Main network fire alarm board includes one SLC and four Style Z/Y (Class A/B) NACs. The main board is mounted on a backplate which can hold up to 9 internal adder modules. This backplate mounts in the BBX-FXMNS enclosure. |

## Network Controller Modules

|   | Model    | Description  |
|---|----------|--|
|    | FNC-2000 | Provides network capability for the FleX-Net™ Fire Alarm panel. One module is required per one network node panel. The FNC-2000 Fire Network Controller module is mounted in position 2 over the FX-2000MNS main board.  |
|  | ANC-5000 | Audio Network Controller module. The ANC-5000 Audio Network Controller module is mounted on a metal plate (which is packaged with the FX-2000MNS) and then the plate is mounted into BBX-FXMNS backbox in position 1 of the QMB-5000N Card Cage.   |
|  | TNC-5000 | Telephone Network Controller module. The TNC-5000 Telephone Network Controller module is mounted below the ANC-5000 Audio Network Controller module and both are mounted on a metal plate and then the plate is mounted into the BBX-FXMNS backbox in position 1 of the QMB-5000N Card Cage. |



### Fiber Optics Module

|   | Model       | Description  |
|---|-------------|--|
|  | FOM-2000-SP | Connects to the FNC-2000 Fire Alarm Network Controller Module and allows fiber optics cabling. |



### Adder Modules

|   | Model                         | Description                    |
|---|-------------------------------|--------------------------------|
|  | DM-1008A, SGM-1004A, RM-1008A | Loop and Circuit Adder Modules |

### Auxiliary Modules

|   | Model      | Description                           |
|---|------------|---------------------------------------|
|    | PR-300     | Polarity Reversal and City Tie Module |
|  | UDACT-300A | Digital Communicator/Dialer Module    |

### Programmable Modules

|   | Model      | Description   |
|---|------------|---|
|  | FDX-008    | Fan Damper Module   |
|  | IPS-2424DS | Programmable Input Switches Module (mounts with the FX-2009-12NDS and can also be part of the RAXN-LCD) |

# FleX-Net™ Mass Notification System (BBX-FXMNS) Enclosure

This enclosure can accommodate all existing modules, except the QMP-5101N Network Master Paging Control module and the QMT-5302N Master Firefighters' Telephone. New models, QMP-5101NV vertical mounting master paging microphone and QMT-5302NV Master Telephone panels are used instead to mount within the BBX-FXMNS Enclosure. The BBX-FXMNS enclosure includes a backbox and a two part door and display deadfront chassis.

**Figure 45: BBX-FXMNS Enclosure**

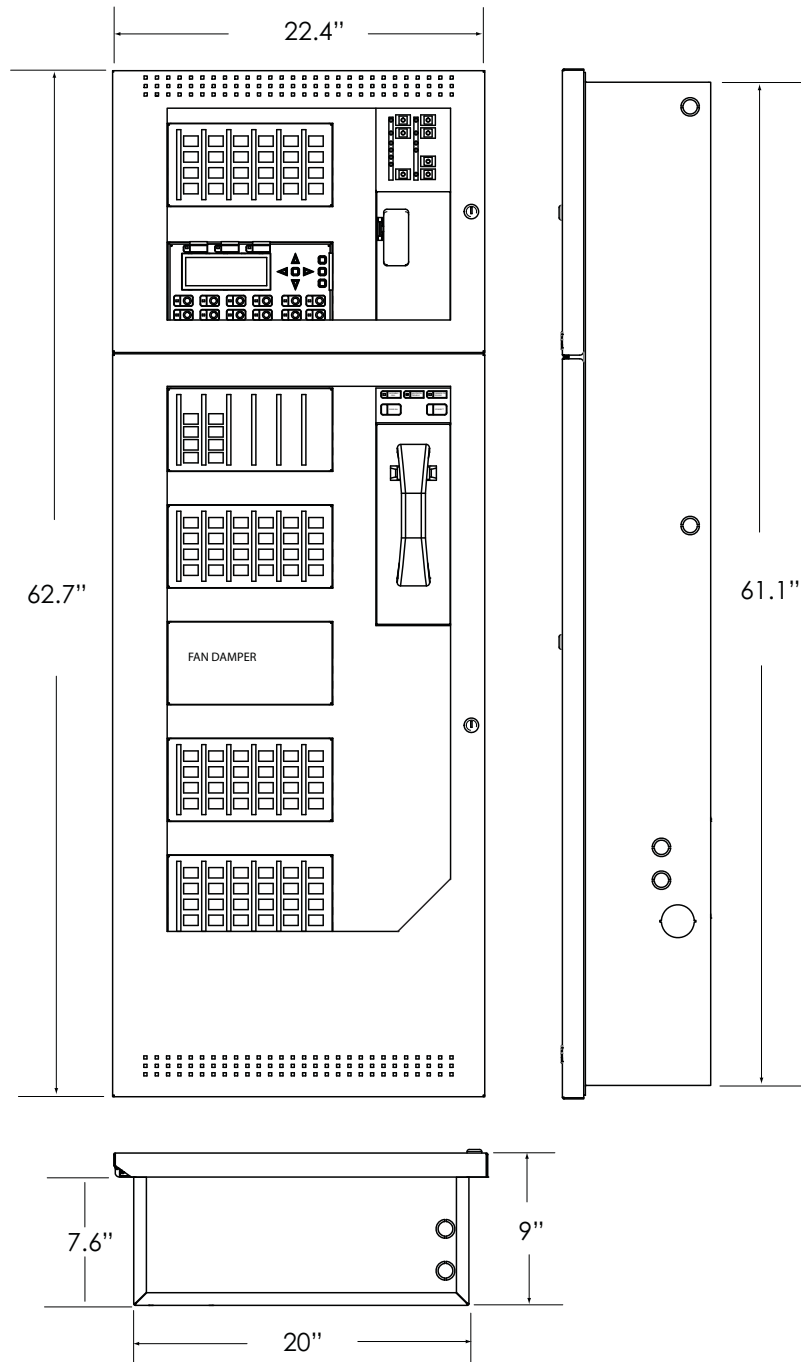

**Notes:** When using the BBX-FMNS as a Mass Notification System (ACU) refer to Appendix I.

The BBX-FXMNS backbox supports the QMB-5000N amplifier backplane and card cage which holds up to four amplifiers, the FX-2000MNS Fire Alarm main board chassis and PS-2040 Power Supply.

**Figure 46: BBX-FXMNS Backbox Dimensions and Contents**

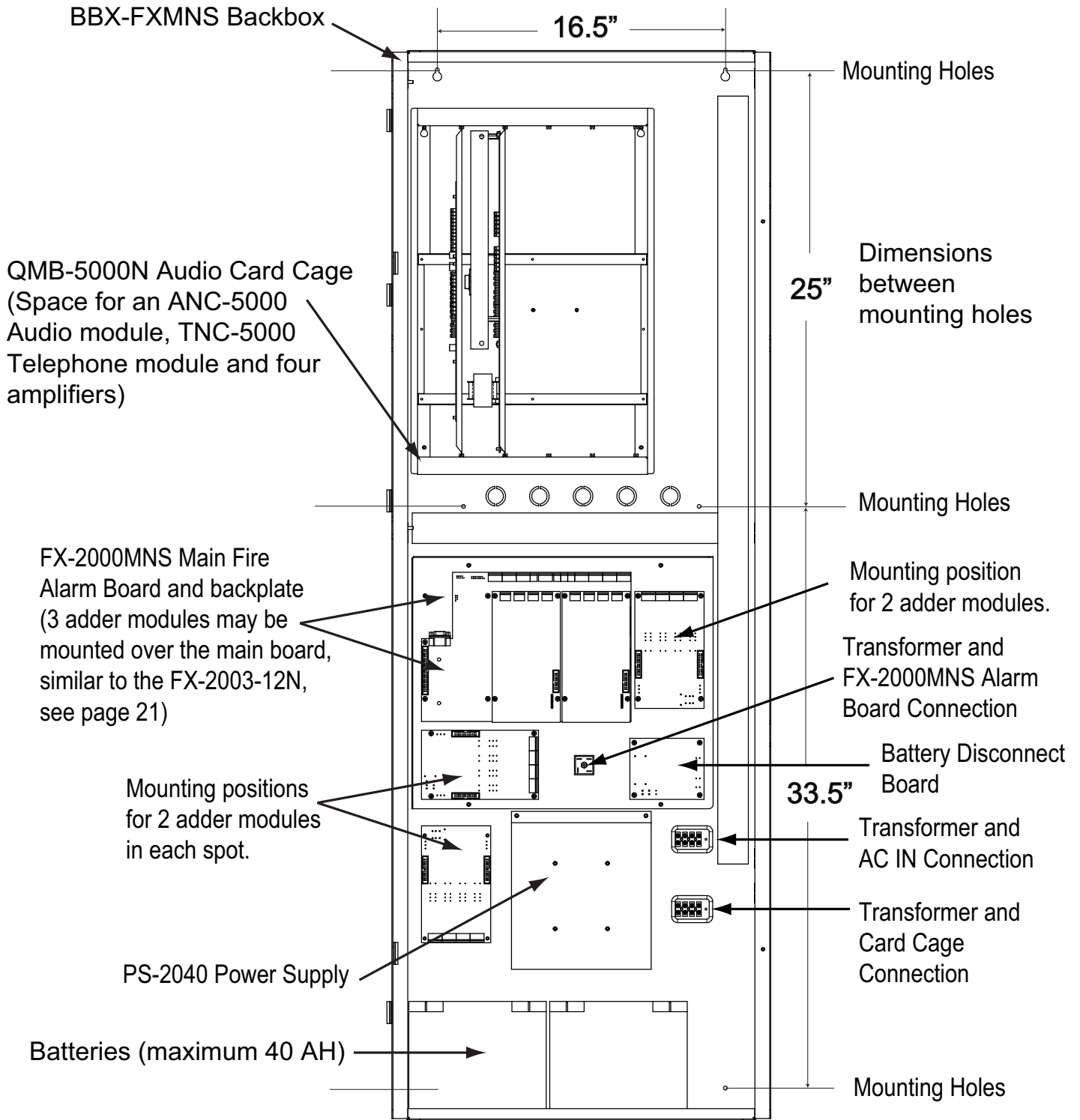



Figure 47: BBX-FXMNS Enclosure Complete View

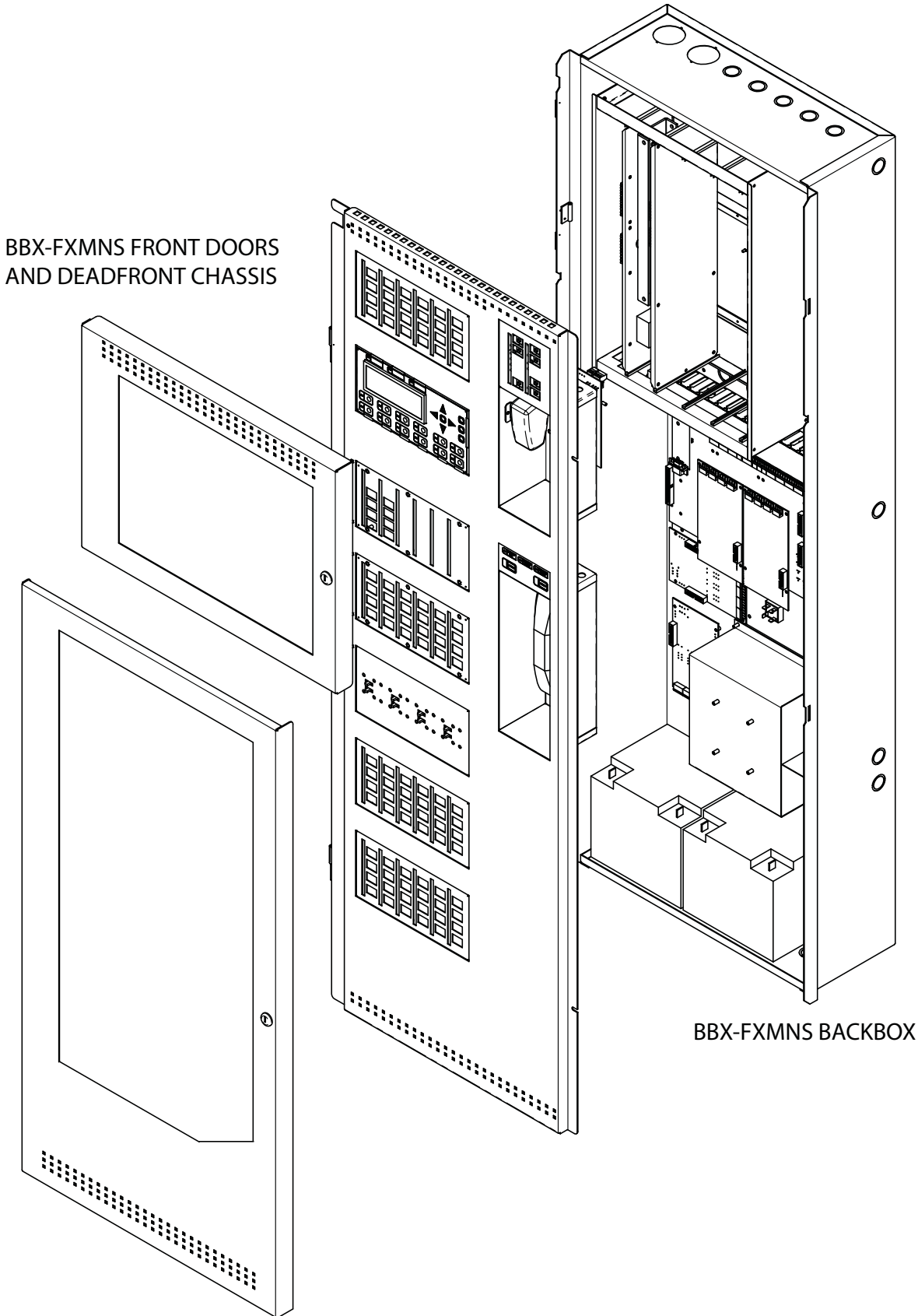
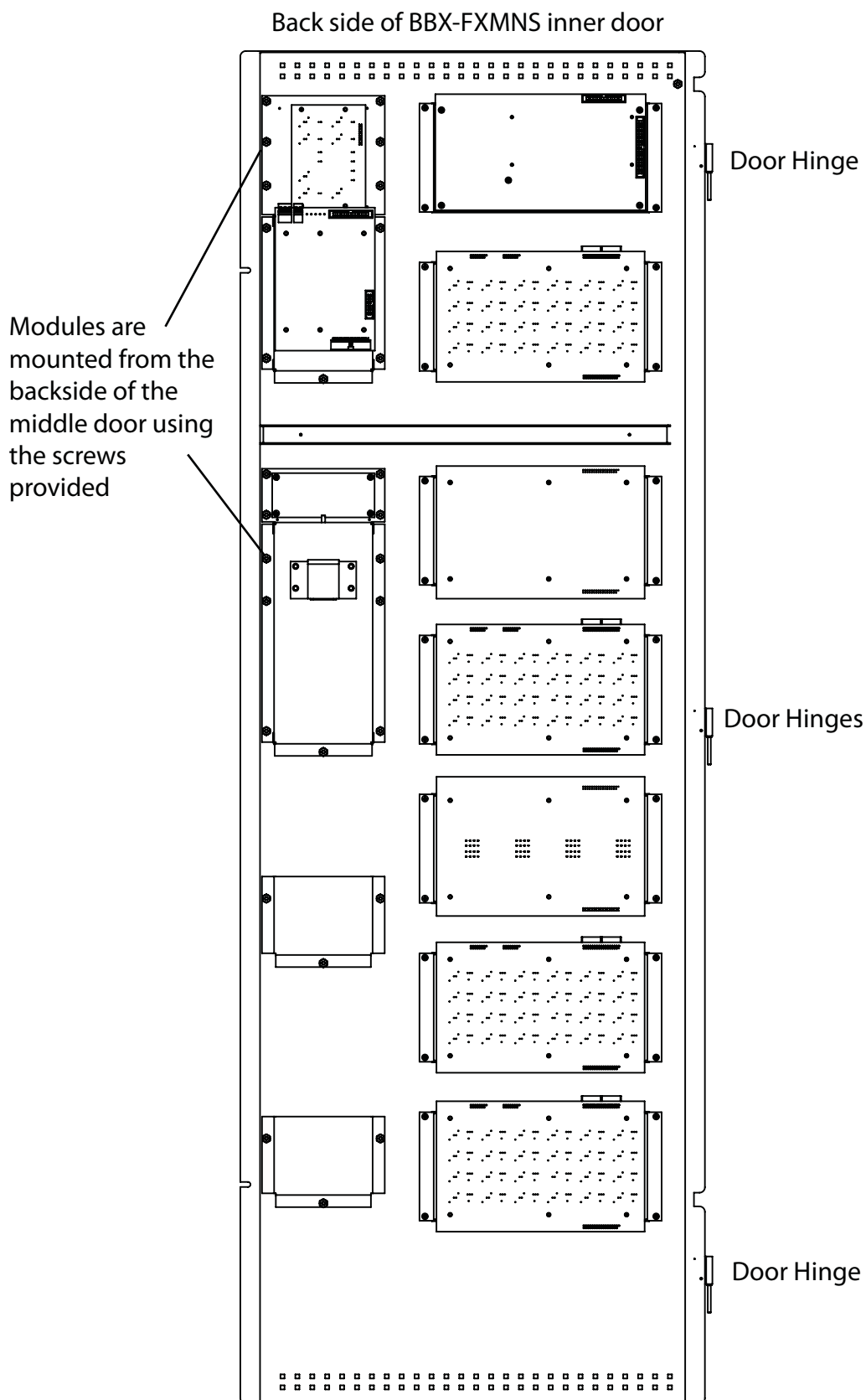

Figure 48: Mounting Vertical Microphone and Telephone Modules in the BBX-FXMNS



# Mechanical Installation for the Expansion Audio Cabinet

## QBB-5001/R Expansion Audio Cabinet Installation

Expansion audio cabinets are mounted as shown in Figure 49 below. The QBB-5001/R is the backbox and door. The QBB-5001/R backbox may be flush or surface mounted. The QBB-5001TR is the metal flush trim. Install all cabinets and enclosures empty. Pull all required wiring in through the conduit holes provided (must be punched out). Do not mount the modules until mechanical installation is complete and all wires have been fed into the cabinets and enclosures.

**Figure 49: Expansion Audio Cabinet Mechanical Installation**

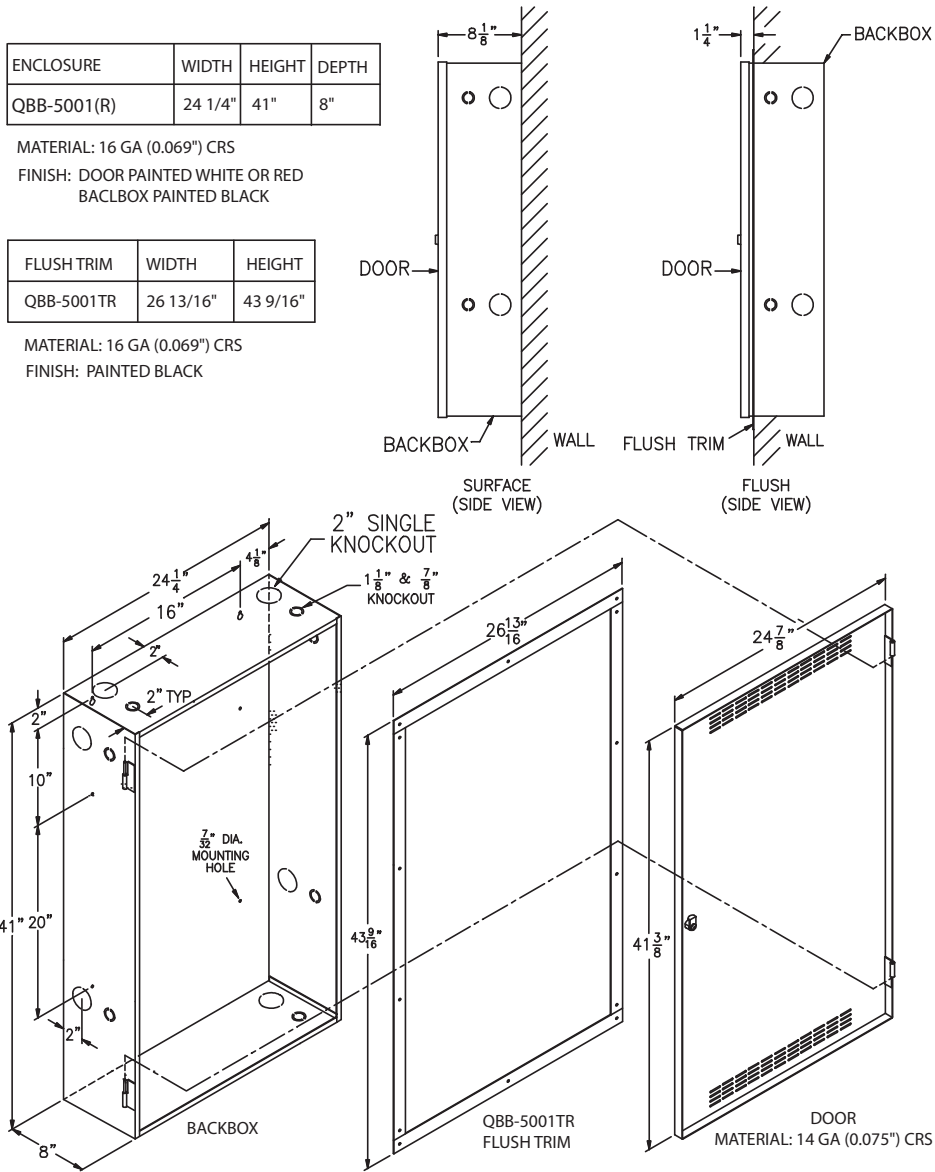

### Notes:

- It is extremely important to connect the audio cabinets earth-ground point (chassis ground) to the earth ground.
- The power supply mounts on the bottom left-hand corner of the backbox and the batteries are placed on the bottom to the right of the power supply. Conduits should be brought in only through the conduits provided at the bottom right hand corner of the cabinet.

# BBX-FXMNS Audio Module Placement and Internal Wiring

The modules that mount into the audio card cage are the amplifier modules. Up to four amplifiers may be installed in each BBX-FXMNS enclosure with one of the four as a backup. Slot #1 is used for the ANC-5000 and/or TNC-5000 modules.

**Figure 50: Integrated Fire/Audio Cabinet Internal Power Wiring.**

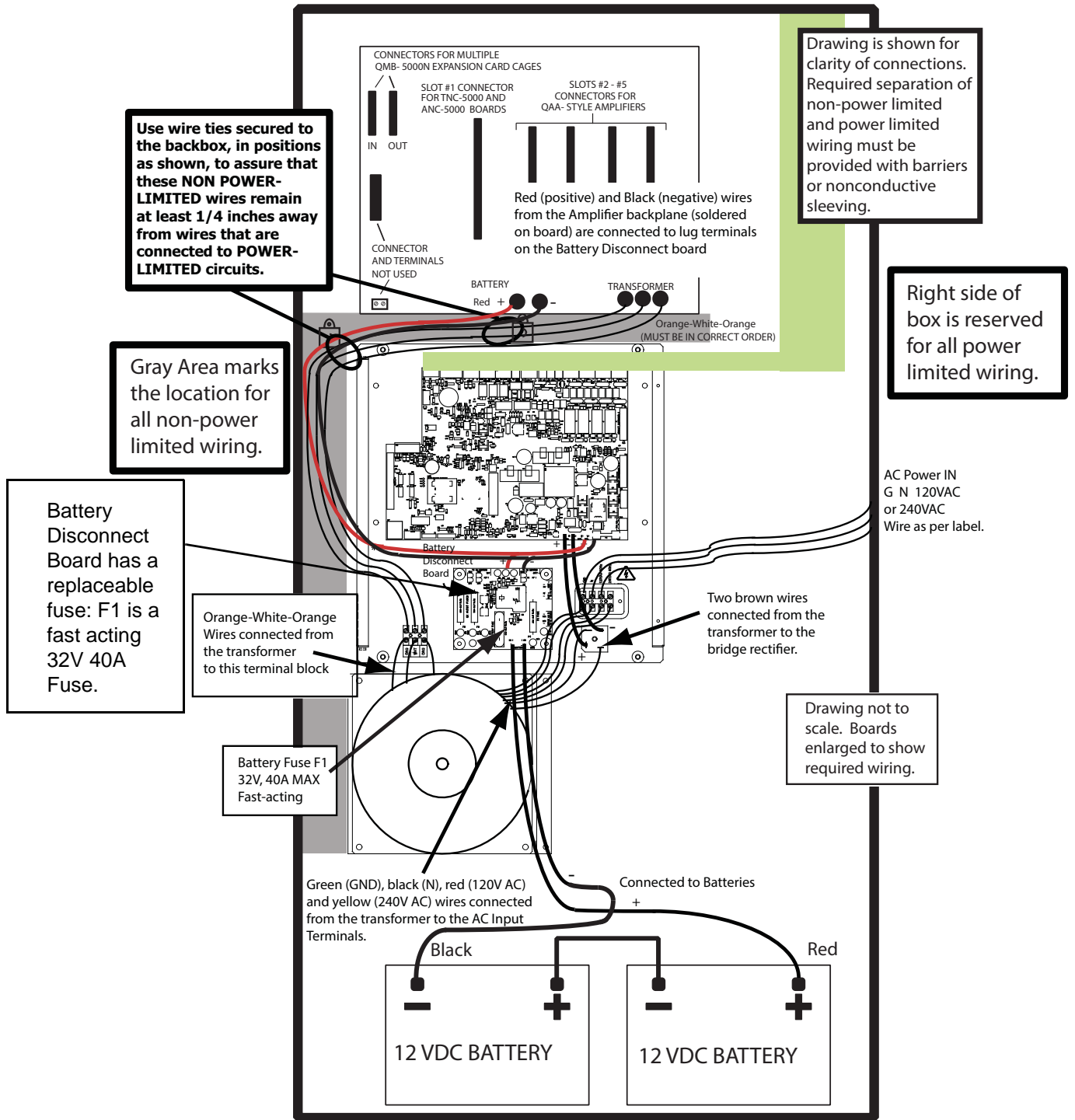

# Integrated Fire Alarm Connection

---

The FX-2000MNS Chassis consists of the Network Fire Alarm main board and chassis.

## Battery Power

The power cable is used to provide power from the batteries to the FX-2000MNS Fire Alarm main board and the audio card cage motherboard. Power from the batteries is first directed to the Battery Disconnect Board, from this board the power is connected to the main fire alarm board and the audio card cage. The red and black wires are soldered on the audio card cage and the spade ends are connected to the red (+) and black (-) connectors on the Battery Disconnect Board. The extra positive and negative wires (from the Y power cable) are connected to the spades on the main fire alarm board and the spade connectors from the bottom of the Battery Disconnect Board are hooked up to the batteries, red (+) and black (-). Refer to Figure 50.

## Transformer Power

The orange, white, orange wires are soldered on the audio card cage motherboard. They are connected to the terminal block located on the power supply cover (which covers the transformer) in the order left to right, orange-white-orange. The orange-white-orange wires from the transformer are connected to the top terminals located on the power supply cover in the same order (orange-white-orange). The yellow wire is connected to the 240V terminal, the red wire from the transformer (120V) is connected to the 120V terminal on the fire alarm chassis, the black wire (from the transformer) connects to the N terminal and the green wire (from the transformer) to the G (Ground) terminal all located on the fire alarm chassis. If using 240V supply connect the yellow wire to the 240V terminal, but do not connect the 120V red wire. The brown wires are connected to the bridge located on the fire alarm chassis. Refer to Figure 50.

# QBB-5001/R Expansion Audio Cabinet Module Placement

The modules that mount into the QBB-5001/R expansion audio cabinet include the QPS-5000N Power Supply, the QMB-5000B Motherboard, and the QBC-5000N Battery Charger. Module interconnects are shown in Figure 51. There is no module installed into Slot #1 of the QMB-5000B Motherboard, as shown below.

Up to seven Amplifier Modules (Models QAA-5230-70/25, QAA-5230S-70/25, QAA-5415-70, QAA-5415-25 and/or QAA-5160-70/25) may be installed into Slots #2 to #8 on the QMB-5000B motherboard. The total maximum wattage per expansion audio cabinet is 360 Watts.

**Figure 51: QBB-5001/R Expansion Audio Cabinet Module Placement**

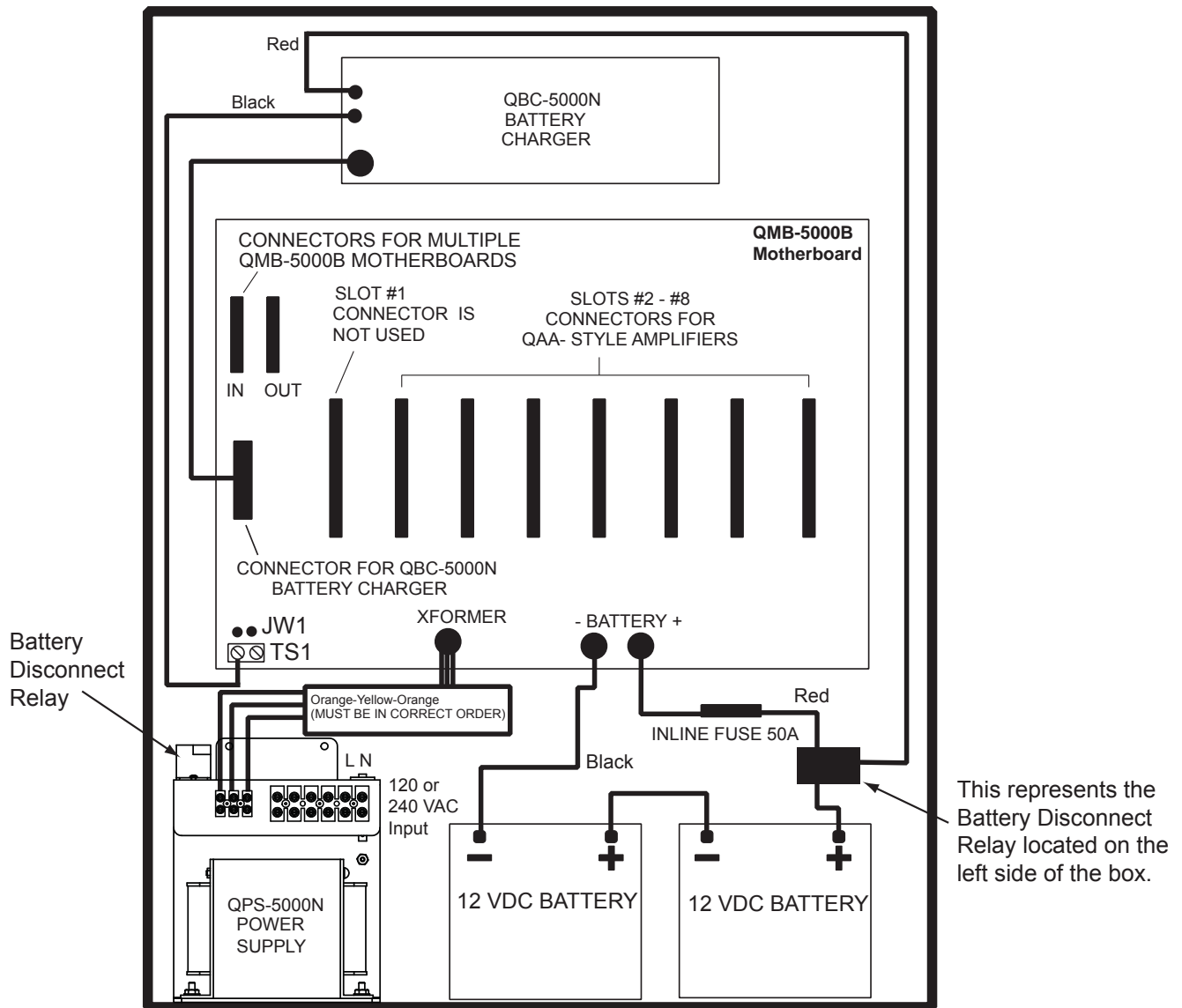

SECURE QPS-5000N POWER SUPPLY TO BACKBOX WITH LUGS AND NUTS PROVIDED

Components on the amplifiers should be facing left when inserted into motherboard. Make sure connections for the power supply and battery charger are as shown above. Place all amplifier modules from left to right in slot positions two to eight. Connect cable MD-525 from the QMB-5000N (inside the BBX-FXMNS or Integrated Fire/Audio Cabinet) to the IN connector at the top left corner of the QMB-5000B Motherboard. Connect cable MD-525 from the QMB-5000B Motherboard (connection marked OUT in the top left corner) to the next expansion audio cabinet QMB-5000B Motherboard (connection marked IN) if another audio cabinet is used. Daisy chain all other expansion audio motherboards used, up to a total of three.

### QPS-5000N Power Supply Connection

Two jumpers are provide as shown in figure below for 120 VAC connection. For 240 VAC application, remove both jumpers and replace one jumper between the two middle terminals. The two terminals on the right are N (neutral), L (live) for AC voltage connection. The three terminals on the left are connected from the QMB-5000N motherboard as orange-white-orange (left to right) in that order.

Figure 52: QPS-5000N Power Supply Wiring Diagram

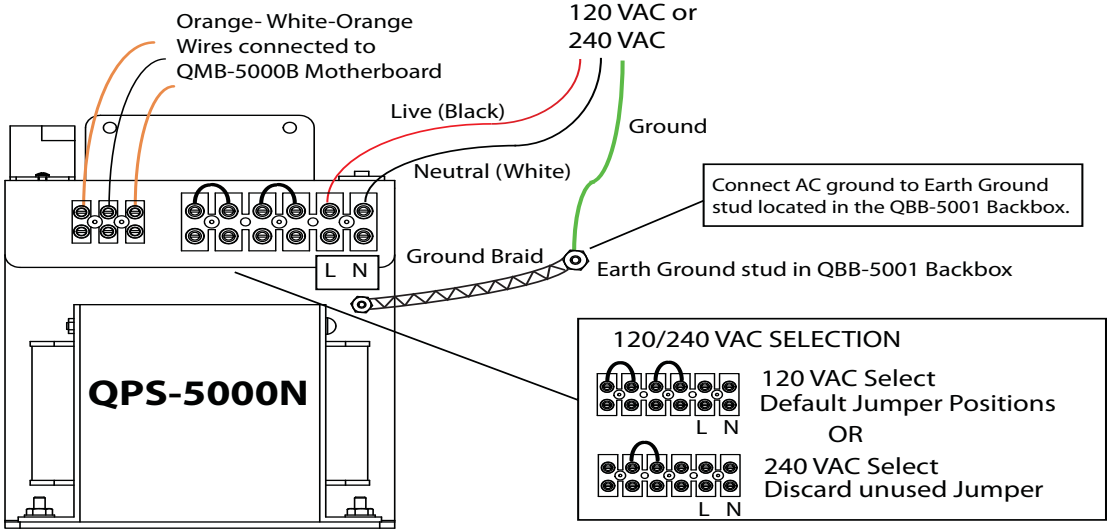

## Installing and Removing Amplifiers

---



**ATTENTION:** Improper installation or excessive force will damage the motherboard and modules being installed or removed.

### Installing QAA Amplifier Modules

1. Hold the amplifier to be installed by the backplate edges. *Do not* handle, push or pull any of the components on the amplifier (especially not the transformer) as this will damage those components.
2. Line up the amplifier being installed with the two plastic runners on the card cage and slide the amplifier back to the point where the amplifier just about touches the pins on the QMB-5000N/B motherboards.
3. Make sure that the amplifier is square with the motherboard.
4. Gently push the amplifier forward to line up the amplifier connector with the motherboard pins. Once you have a sense of feel that the amplifier connector and the motherboard pins are properly lined up, place one thumb on the top edge of the backplate and the other thumb on the bottom of the backplate and carefully push the amplifier in. You should hear a slight thud sound when the amplifier is snapped into place.



**Note:** If the amplifier connector is not properly lined up with the motherboard pins, or if excessive force is used, the pins on the motherboard can be damaged.

### Removing the QAA Amplifier Modules

1. Disconnect all cables connected to the amplifier. *Do not* handle, push or pull any of the components on the amplifier (especially not the transformer) as this will damage those components.
2. Place the forefinger of one hand on the top inside edge of the front heat sink (the heat sinks are the two long silver channel-like metal covers opposite the backplate) and the forefinger of the other hand on the bottom edge of the backplate behind the card cage frame.
3. Carefully pull and rock the amplifier forward until the amplifier connector is disconnected from the motherboard pins.
4. Holding the amplifier firmly by the backplate edges, slide the amplifier forward and completely remove it from the card cage.



**ATTENTION:** Power should be disconnected before removing and inserting modules.

## Multiple QBB-5001/R Cabinet Connections

---

When multiple QBB-5001/R audio cabinets are used in an installation, each has its own QPS-5000N Power Supply, QBC-5000N Battery Charger, and batteries. A total of three audio cabinets may be used by simply interconnecting with Mircom MD-525 Extension Cables from the QMB-5000N "Out" Connector, to the "In" Connector on the next QMB-5000B motherboard.

### QMB-5000B Motherboards #1, #2, and #3

Up to a maximum of three QBB-5001/R Audio Cabinets may be connected to a BBX-FXMNS or Integrated Fire/ Audio Cabinet. The first QMB-5000N "Node" Motherboard has a connection from the FX-2000MNS. The next three QBB-5001/R Audio Cabinets contain QMB-5000B Motherboards #1, #2 and #3 which are connected with the regular ribbon cable MD-525. The MD-525 cable is connected from the output connector on the QMB-5000N "node" motherboard to the input connector on QMB-5000B motherboard #1. Another MD-525 cable is connected from the output connector on motherboard #1 to the input connector on motherboard #2 (see Figure 53 below). Again another MD-525 cable is connected from the output connector on motherboard #2 to the input connector on



motherboard #3.

**Figure 53: Interconnecting Extra QMB Motherboard**

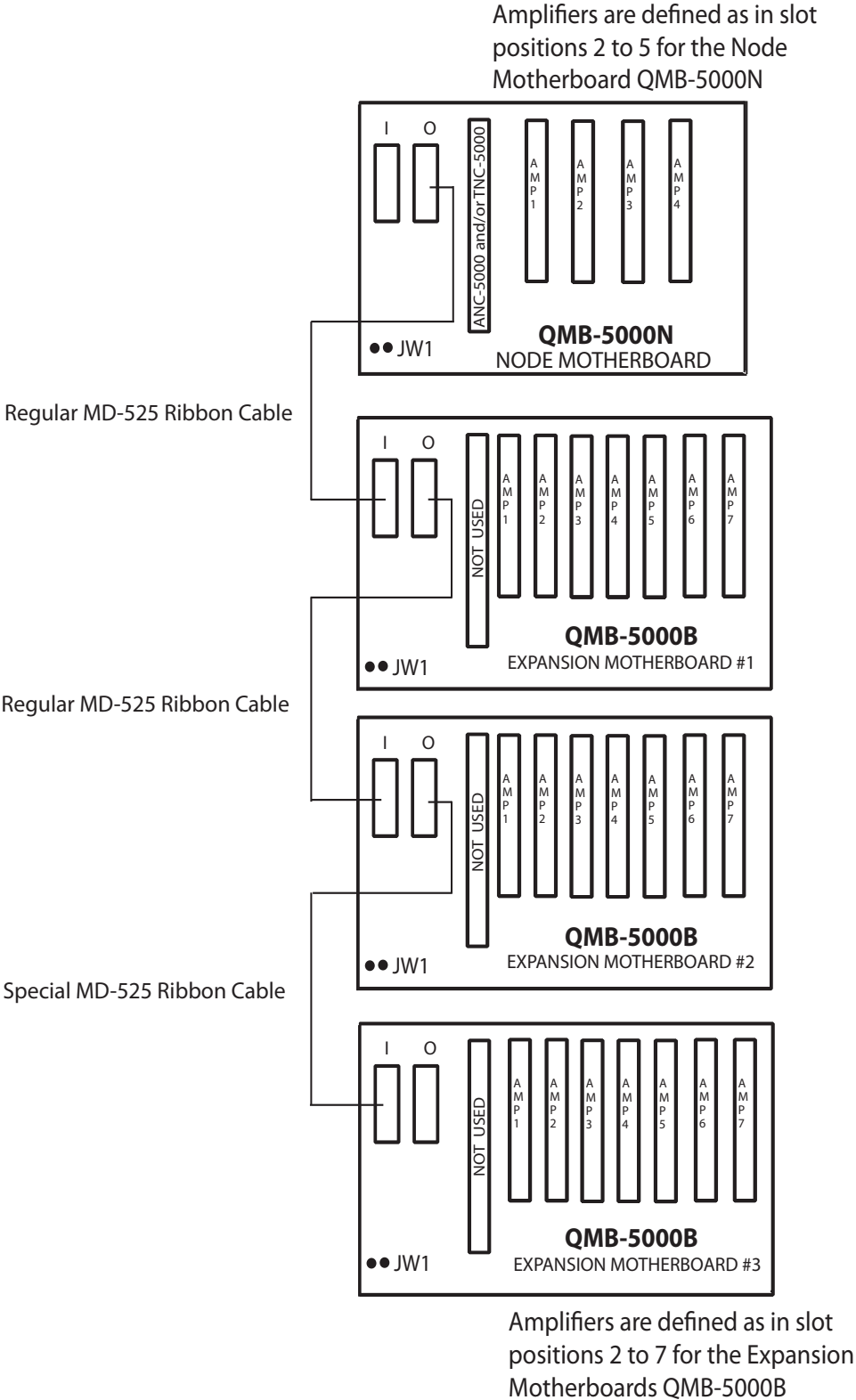

**Note:** Jumper JW1 (located in the bottom left-hand corner of the backplane) is installed for expansion cabinets #1 to 3.



# Audio Network Card and Telephone Network Card

Each Integrated Fire/Audio Cabinet requires an ANC-5000 Audio Network Controller Card. The TNC-5000 Telephone Controller Network card is necessary only if Telephone circuits are required. Below is a diagram for mounting both audio and telephone cards into the large network fire alarm chassis, FX-2009-12NDS.

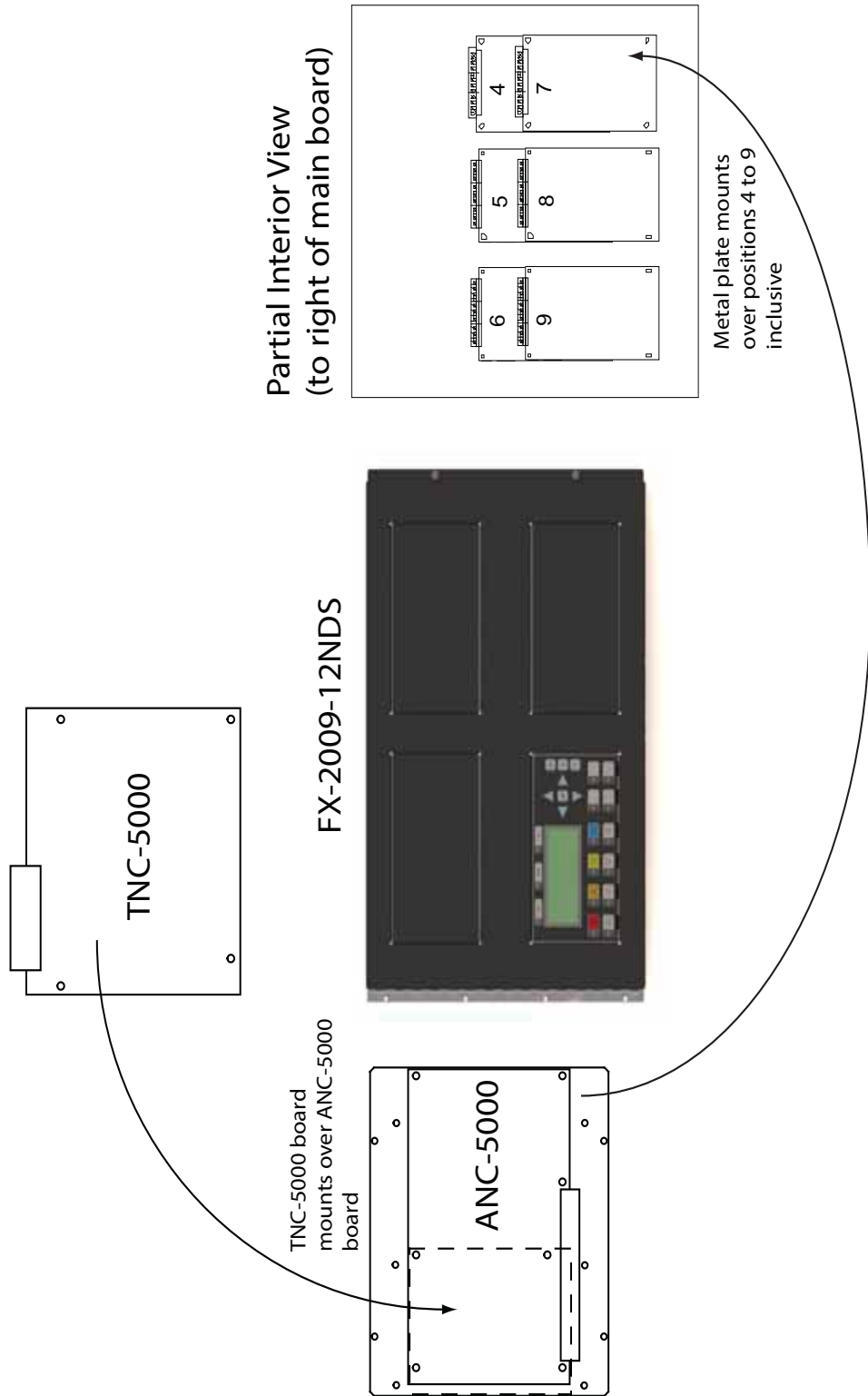

# Audio Amplifier Wiring

There are five types of amplifiers available:

| Amplifier              | Description  |
|------------------------|--|
| <b>QAA-5230-70/25</b>  | Two 30 watt individually supervised speaker outputs, 70V or 25V            |
| <b>QAA-5230S-70/25</b> | Two 30 watt split into four 15 watt supervised speaker outputs, 70V or 25V |
| <b>QAA-5415-70</b>     | Four 15 watt individually supervised speaker circuits, 70V                 |
| <b>QAA-5415-25</b>     | Four 15 watt individually supervised speaker circuits, 25V                 |
| <b>QAA-5160-70/25</b>  | One 60 watt supervised speaker circuit, 70V or 25V                         |

## QAA-5230-70/25 Amplifier Wiring

The QAA-5230-70/25 dual 30 watt amplifier is made up of two 30 watt supervised speaker outputs. Each circuit may be wired as Class A or Class B. Amplifier is set to 70V, if 25V is required, remove orange molex connector cable labelled MD-787 and replace with blue molex connector cable labelled MD-788.

**Figure 54: QAA-5230-70/25 Wiring**

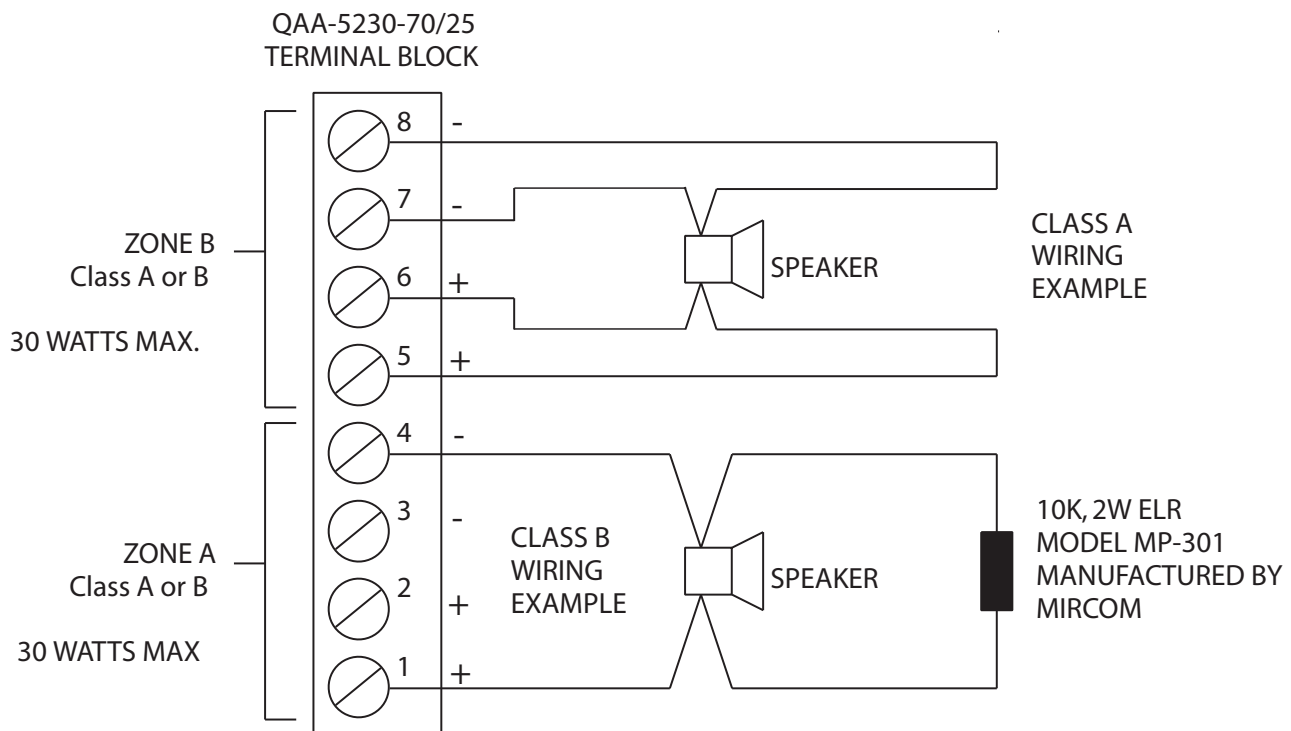

**Notes:**

- All circuits are power limited and supervised.
- Cut jumper J1 when using an isolator.
- There are two fuses on this board. Both are 4A fast blow.
- See speaker wiring chart for wire gauge selection.

**Figure 55: Using a Speaker Isolator**



**Note:** When using a speaker isolator (SIS-204 or SISA-204 for use in Canada only), jumper JP1 (top left-hand corner, component side) must be cut on the QAA-5230-70/25 and on the QAA-5160-70/25.

CUT JUMPER JP1 WHEN USING A SPEAKER ISOLATOR

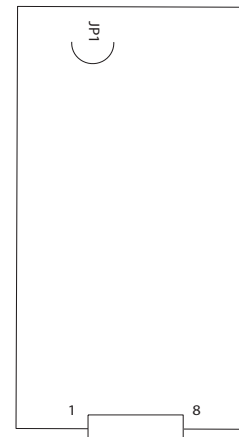

QAA-5230-70/25 AND QAA-5160-70/25 AMPLIFIERS

**QAA-5230S-70/25 Amplifier Wiring**

QAA-5230S-70/25 dual 30 watt amplifier has two 30 watt amplifiers. Each amplifier has two Class B 15 watt supervised speaker circuits. Each circuit is wired to provide two separate speaker zones on the same floor. Amplifier is set to 70V, if 25V is required, remove orange molex connector cable labelled MD-787 and replace with blue molex connector cable labelled MD-788.

**Figure 56: QAA-5230S-70/25 Wiring**

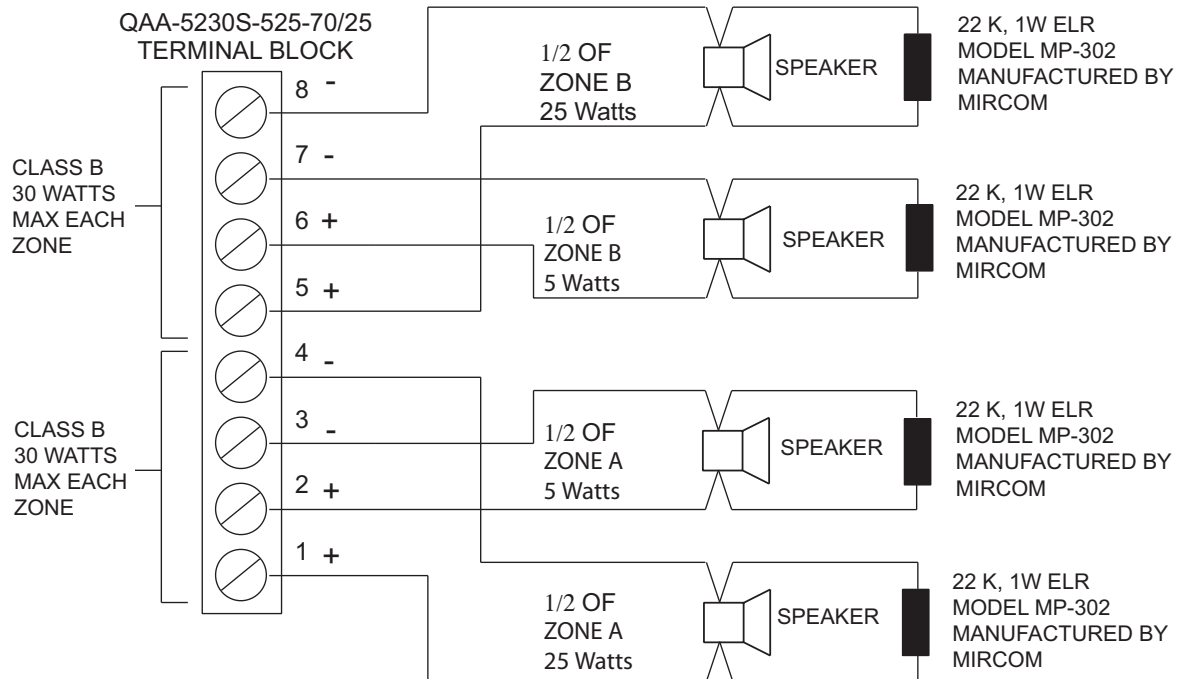

**Notes:**

- All circuits are power limited and supervised.
- There are six fuses on this board. Two are 8A fast blow and four are 1/2A fast blow for the 70V version and two are 8A fast blow and four are 1.25 A fast blow for the 25V
- See speaker wiring chart for wire gauge selection.

### QAA-5415-70 and QAA-5415-25 Amplifier Wiring

QAA-5415-70 quad 15 watt amplifier has four 15 watt amplifiers. Each amplifier has one Class B 15 watt supervised speaker circuit. Each circuit is wired such as to provide one separate speaker zone. The QAA-5415-70 may be wired as Class A by using a QAA-4CLA Class A converter, see Figure 59. The QAA-5415-25 is the same quad amplifier as the QAA-5415 but instead of 70 Volts it is 25 Volts.

**Figure 57: QAA-5415-70 or QAA-5415 Wiring**

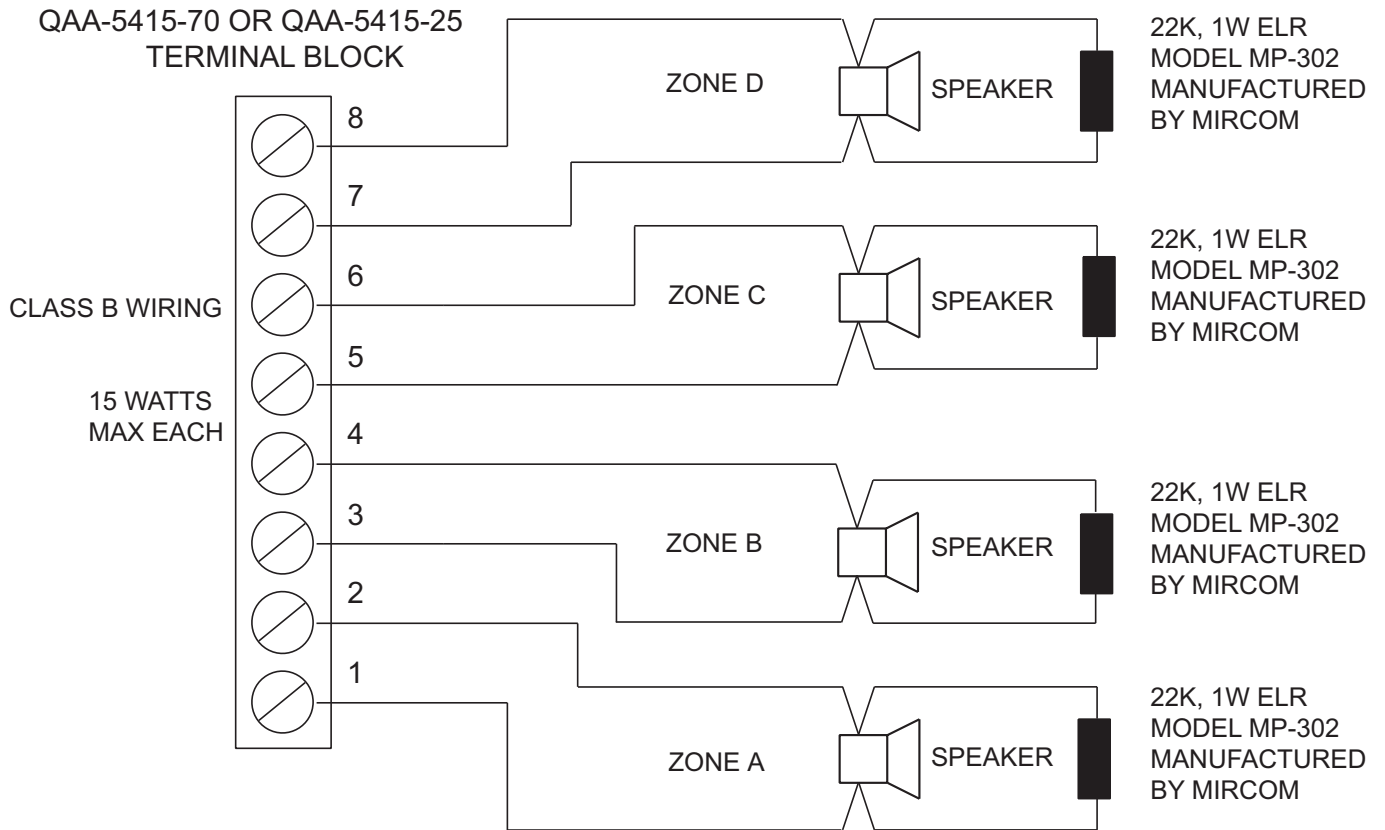

**Notes:**

- All circuits are power limited and supervised.
- There are four 3A fast blow fuses on this board.
- See speaker wiring chart for wire gauge selection.

**Figure 58: Using a Speaker Isolator with the QAA-5415-70 or QAA-5415-25 Amplifiers**

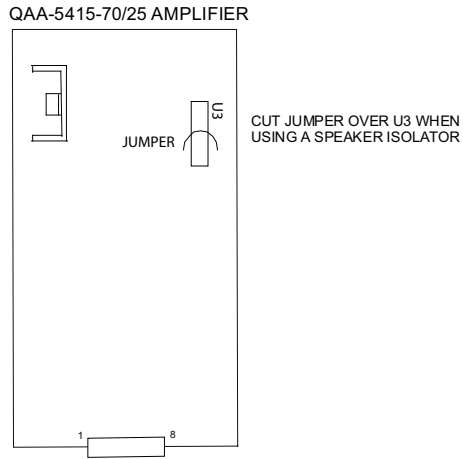

**Note:** When using a speaker isolator (SISA-204 or SISA-204 for use in Canada only), jumper JP1 (top left-hand corner, component side) must be cut on the QAA-5230-70/25 and on the QAA-5160-70/25.

Figure 59: QAA-4CLA Class A Converter For QAA-5415-70/25 Amplifier

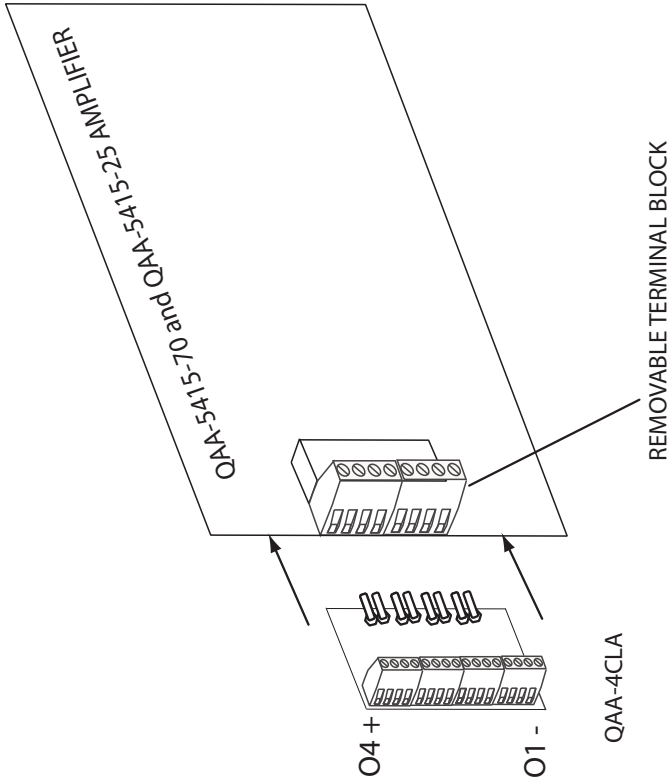
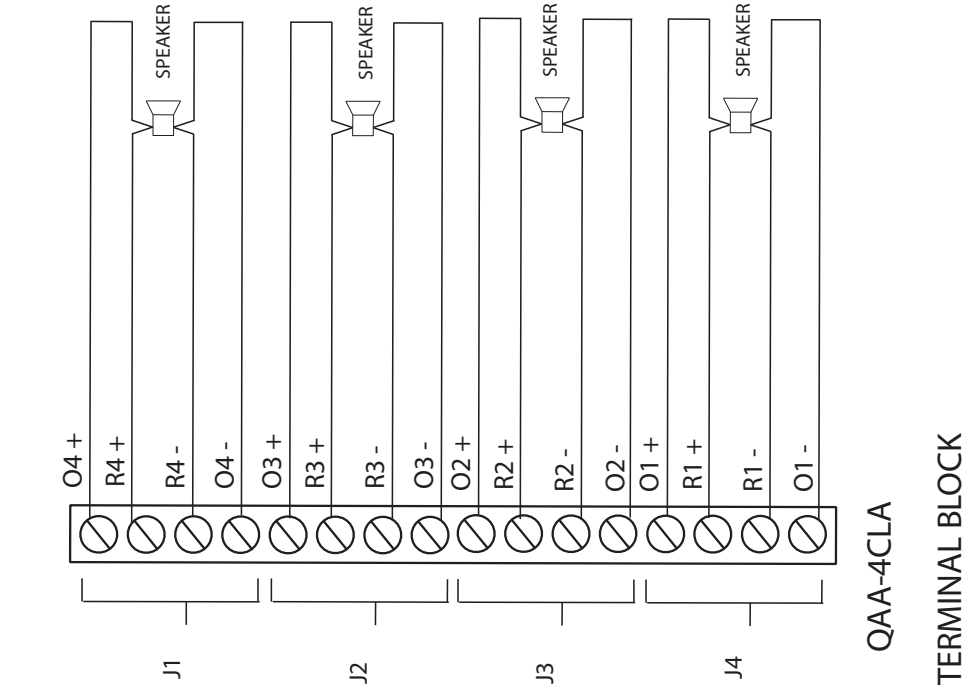

- NOTES:**
1. TO WIRE QAA-4CLA, REMOVE TERMINAL FROM QAA-5415-70 or QAA-5415-25 AMPLIFIER, CONNECT TO QAA-4CLA AND SCREW DOWN. WIRE THE FOUR CLASS A CIRCUITS TO THE 16 TERMINALS AS SHOWN IN DIAGRAM AT RIGHT.
  2. ALL CIRCUITS ARE POWER LIMITED.
  3. 15 WATTS MAX. PER ZONE.

Figure 60: QAA-4CLAS Class A Converter For QAA-5230S-70/25 Amplifier

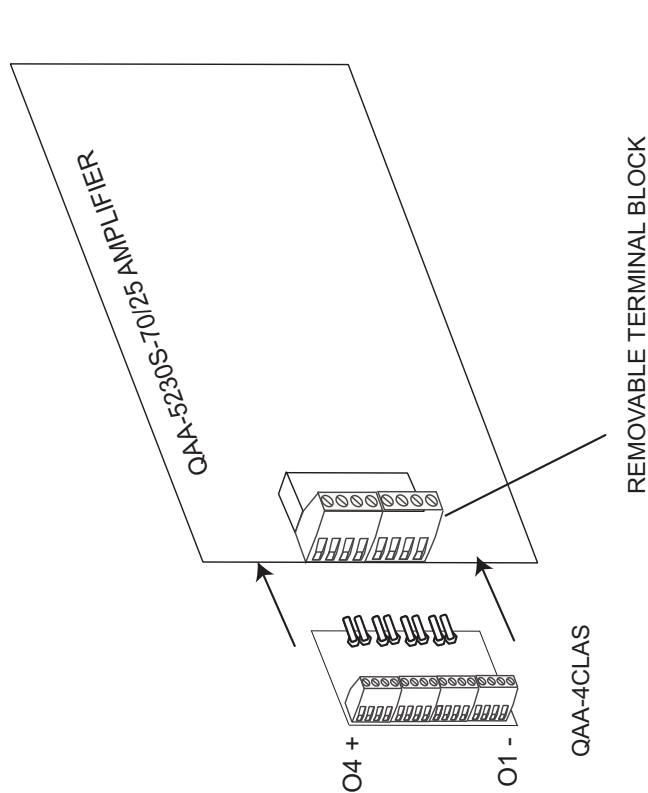
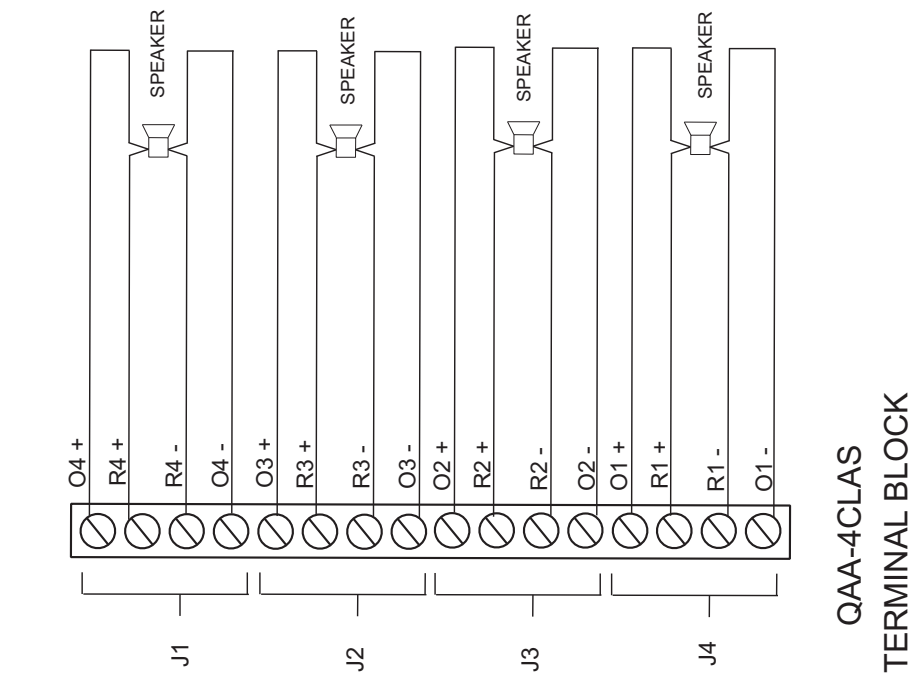

**NOTES:**

1. TO WIRE QAA-4CLAS, REMOVE TERMINAL FROM QAA-5230S-70/25 AMPLIFIER, CONNECT TO QAA-4CLAS AND SCREW DOWN. WIRE THE FOUR CLASS A CIRCUITS TO THE 16 TERMINALS AS SHOWN IN DIAGRAM AT RIGHT.
2. ALL CIRCUITS ARE POWER LIMITED.
3. 15 WATTS MAX. PER ZONE.



## QAA-5160-70/25

This amplifier provides one 60 Watt supervised speaker circuit either 70 Volts or 25 Volts which may be wired Class A or Class B.



**Note:** When using this amplifier as a backup amplifier, the molex connector MD-789 must be added (see the following section on the backup amplifier for more information). When using a speaker isolator (SIS-204 or SISA-204 for use in Canada only), jumper JP1 (top left-hand corner, component side) must be cut on the QAA-5160-70/25 board (for details, see Figure 55).

**Figure 61: QAA-5160-70/25 Wiring**

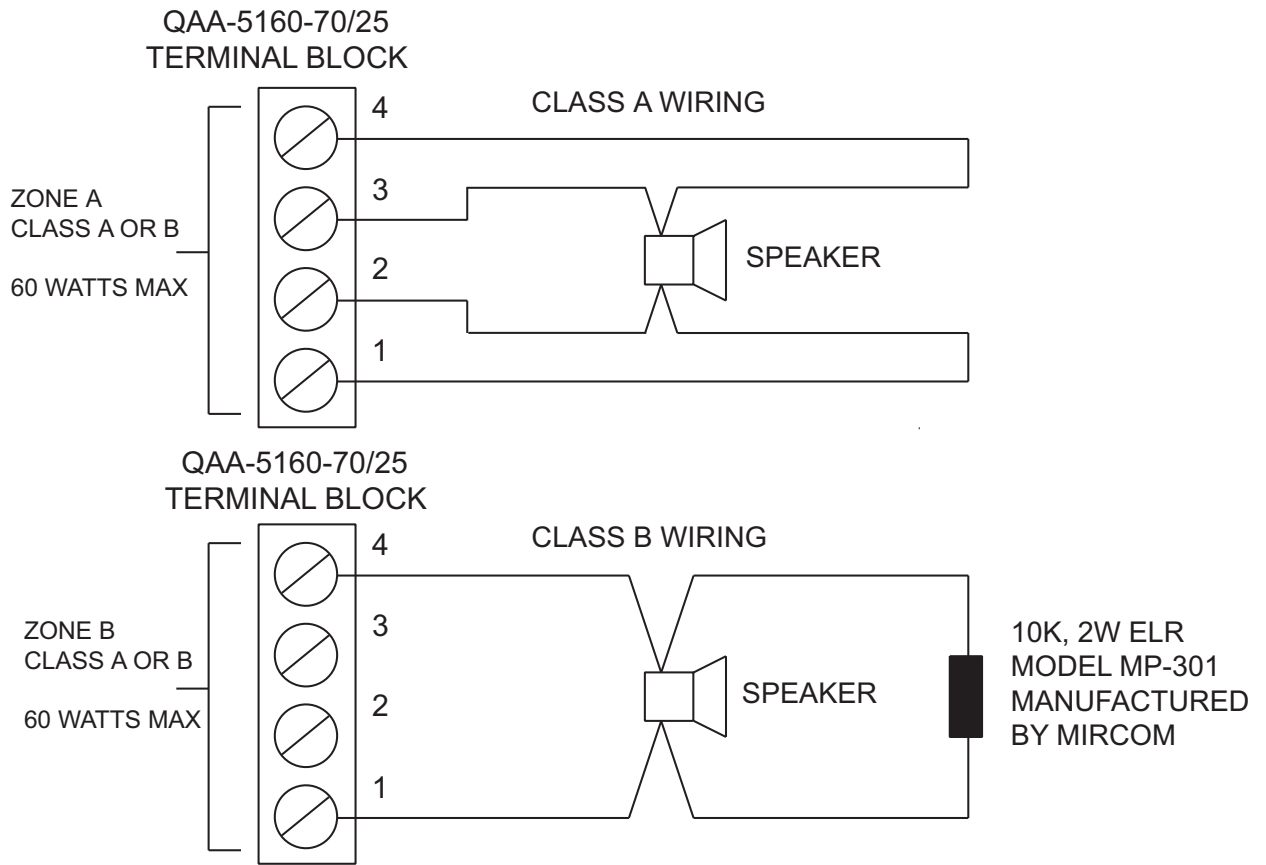

**Notes:**

- All circuits are power limited and supervised.
- There are two fuses on this board. Both are 8A fast blow.
- See speaker wiring chart for wire gauge selection.

**Table 12: Wiring Chart for 70V Speakers**

| Total Power | Maximum Wiring Run To Last Device (ELR) |     |       |      |       |      |       |      |
|-------------|---|-----|-------|------|-------|------|-------|------|
|             | 18AWG                                   |     | 16AWG |      | 14AWG |      | 12AWG |      |
| Watts       | ft                                      | m   | ft    | m    | ft    | m    | ft    | m    |
| 15          | 2500                                    | 762 | 4000  | 1219 | 6000  | 1828 | 8000  | 2438 |
| 30          | 1500                                    | 457 | 2500  | 762  | 4000  | 1219 | 6000  | 1828 |
| 60          | 750                                     | 228 | 1200  | 365  | 2000  | 609  | 3500  | 1066 |



**Notes for Wiring Charts:**

1. For each speaker zone, select the total zone power.
2. Distance shown is calculated to the last speaker, based on the worst case with all speakers lumped at the end.
3. Calculation is based on a 1db power loss (20%) and a source of 70V or 25V.

**Table 13: Wiring Chart for 25V Speakers**

| Total Power | Maximum Wiring Run To Last Device (ELR) |     |       |     |       |     |       |     |
|-------------|---|-----|-------|-----|-------|-----|-------|-----|
|             | 18AWG                                   |     | 16AWG |     | 14AWG |     | 12AWG |     |
| Watts       | ft                                      | m   | ft    | m   | ft    | m   | ft    | m   |
| 15          | 625                                     | 190 | 1000  | 305 | 1500  | 457 | 2000  | 609 |
| 30          | 375                                     | 114 | 625   | 191 | 1000  | 305 | 1500  | 457 |
| 60          | 187                                     | 57  | 300   | 91  | 500   | 152 | 875   | 267 |

## Backup Amplifier

Any amplifier may be designated as a backup amplifier when backup is required. It should be installed in any audio cabinet and in the right-most slot position of a QMB-5000B backplane.

**Figure 62: QAA-5160-70/25 Amplifier (Backup Application)**

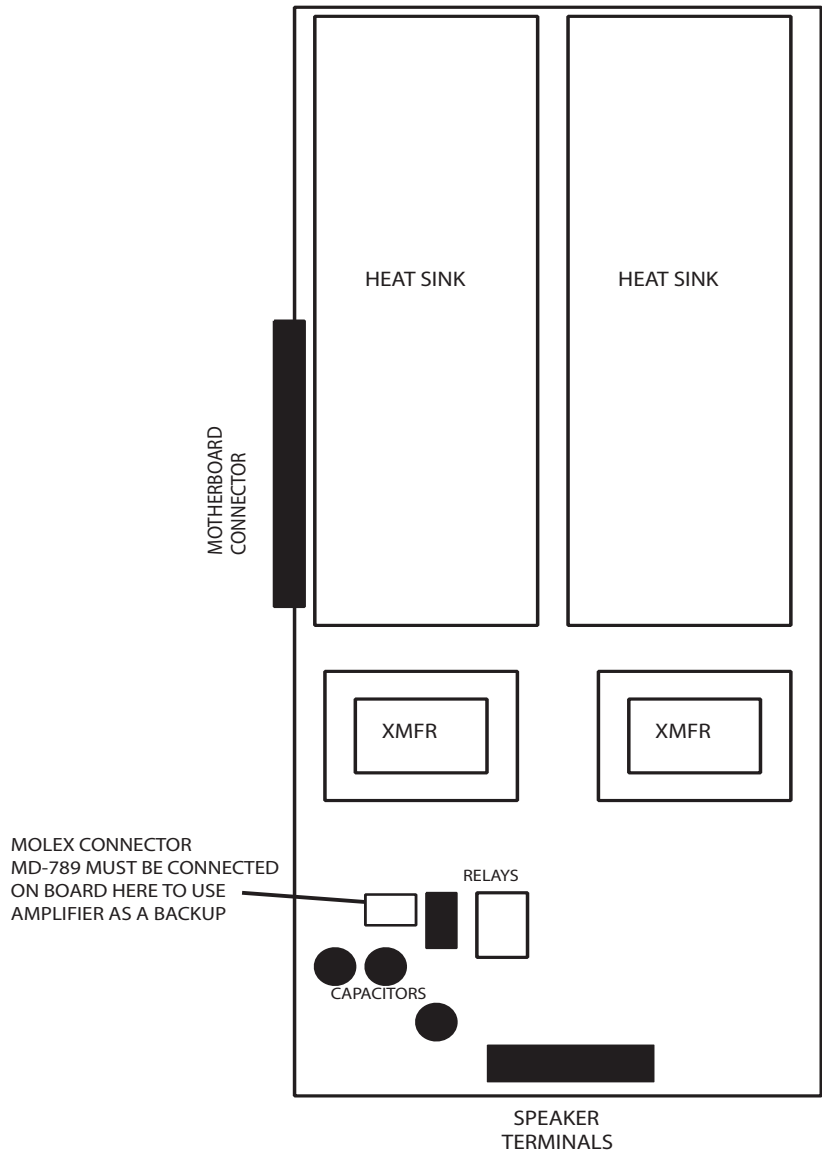

Any amplifier may be designated as the backup amplifier and this backup amplifier must have the MD-789 molex connector placed in the bottom left-hand corner of the board as shown in the adjacent figure. The QAA-5160-70/25 as backup amplifier is inserted into the motherboard. No connections are made to the backup amplifier's terminals except for end-of-line resistors which are to be placed directly on the terminals in the audio cabinet.

Once the Backup Amplifier is installed, it must be properly configured. Refer to the Audio Configuration for details.

The number of backup amplifiers is limited to one per node. Only the first failed amplifier gets the backup. The distance from the farthest audio cabinet to the audio cabinet (which has the backup amplifier) cannot be greater than four cable lengths (approximately 208 inches or 17 feet).

# Displays & Controls

**Figure 63: Audio Cabinet Displays and Controls**

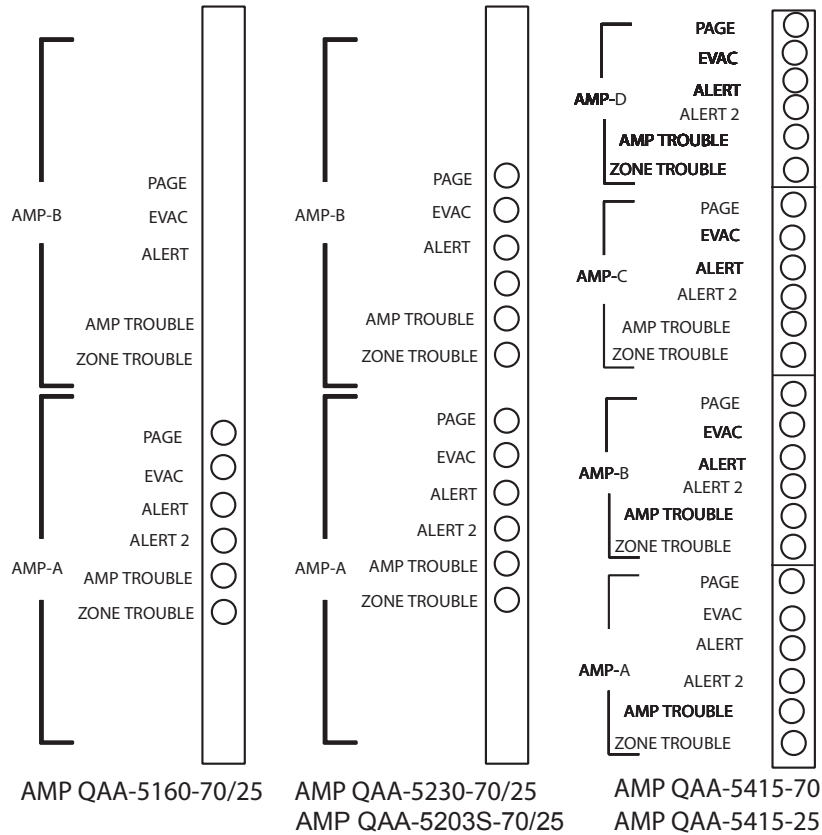

## Amplifier Displays

### Page

The amplifier is connected to voice paging. Paging occurs on that particular amplifier zone.

### Evac

The amplifier is connected to the evacuation tone.

### Alert

The amplifier is connected to the alert tone.

### Alert 2

The amplifier is connected to the alert tone 2.

### Amp Trouble LED

Indicates an amplifier trouble by illuminating steady amber.

### Zone Trouble LED

Indicates a zone field wiring trouble, by illuminating steady amber.



**Notes:**

- The QAA-5160-70/25 only has displays for "Amp-A", while the QAA-5230-70/25 & QAA-5203S-70/25 has displays for both "Amp-A" & "Amp-B".
- Each single amplifier comes with a blank black sticker to place over the Amp B information on the amplifier chassis.
- Each four circuit amplifier comes with its own sticker to place over the Amp A and B information on the amplifier chassis.

# Setup

## QBB-5001/R Amplifier Installation

The following instructions are based on the assumption that the fire alarm is already installed.

1. Install the QBB-5001/R Audio Backbox and door in the desired location.
2. Install the QMB-5000B Motherboard / Card-Cage into the backbox.
3. Install the QBC-5000N Battery Charger into the backbox. Connect its cable to J1 on the motherboard.
4. Install the QPS-5000N Power Supply into the QBB-5001/R backbox. Be careful: the QPS-5000N is *very heavy*.
5. Connect the heavy orange - yellow - orange wires from the motherboard to the power supply being careful to match the wire colour to the labelling on the power supply.
6. Connect the un-powered 120 VAC line power and chassis ground to the power supply following the labelling. Ground the power supply to the box. *Do not apply AC power at this time.*
7. Install the two 12 VDC batteries into the backbox.
8. Connect the battery cables from the motherboard to the batteries as shown in Figure 50, but do not connect the cable between the batteries at this time.

When plugging in these amplifiers, the components are facing left. Slide the amplifier in place and to avoid damage, making sure that the edge connector is properly mating with the header on the motherboard. Keep the amplifier as straight and level as possible and use even pressure on the top and bottom. The amplifier is connected properly after it snaps into place.



**ATTENTION:** Powering the system with incorrectly installed amplifiers will cause permanent damage.

9. Connect and check (for opens, shorts, and ground) all the amplifiers' field wiring.

## Before Turning the Power "ON"...

The entire system installation should be completed first.

To prevent sparking, *do not* connect the batteries. Connect the batteries after powering the system from the main A.C. supply.

1. Check and secure all interconnection wiring cables.
2. Check and secure all interconnection wiring cables to the Fire Alarm Control Panel.
3. Check the A.C. power wiring for proper connection.
4. Check that the chassis is connected to earth ground.

## Audio Configuration

The configuration of the Flex-Net™ is accomplished via the MSW-025 Personal Computer based Configurator Software.

| <b>NOTICE TO USERS, INSTALLERS, AUTHORITIES HAVING JURISDICTION, AND OTHER INVOLVED PARTIES</b>   |                            |                     |                              |
|---|----------------------------|---------------------|------------------------------|
| This product incorporates field-programmable software. In order for the product to comply with the requirements in the Standard for Control Units and Accessories for Fire Alarm Systems, UL 864, certain programming features or options must be limited to specific values or not used at all as indicated below. |                            |                     |                              |
| Program feature or option   | Permitted in UL 864? (Y/N) | Possible settings   | Settings permitted in UL 864 |
| Master Telephone Buzzer Disable   | No                         | Enabled or Disabled | Not permitted                |

# Lobby Enclosures

The QMP-5101N paging and QMT-5302N telephone control modules fit into the BB-5008 and BB-5014 lobby backboxes. All selector panels mount into the BB-5008 and BB-5014 backboxes also. Below find the dimensions for both the backboxes.

**Figure 64: BB-5008 and BB-5014 Backboxes**

**BB-5014 Lobby Backbox**

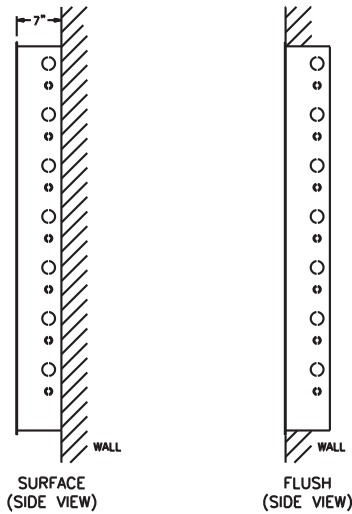

**BB-5008 Lobby Backbox**

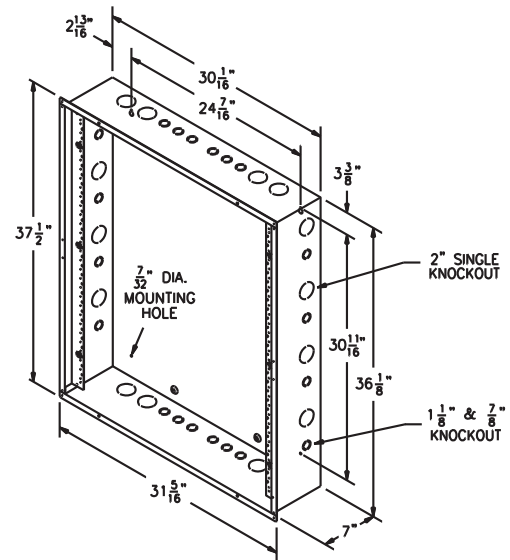
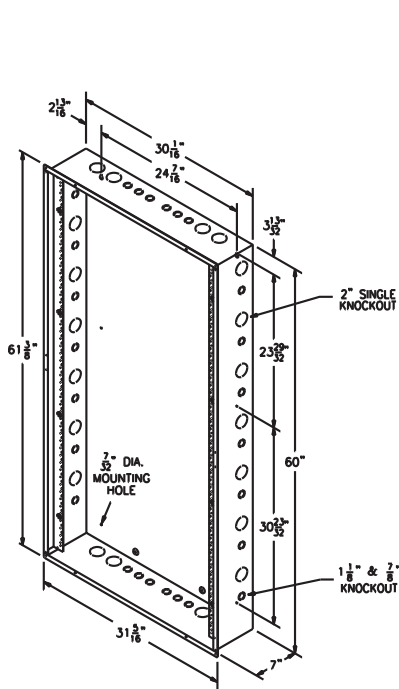
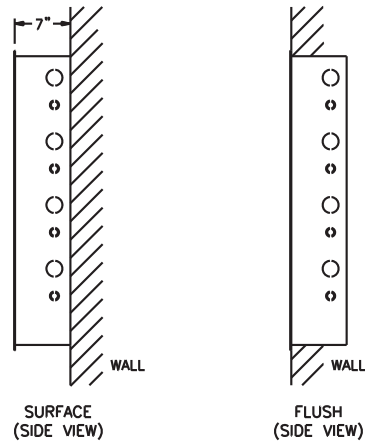

**Notes:**

- Material: 16GA (0.059") cold rolled steel.
- Finish: painted.
- Allow 4" gap between flanges of the backboxes when installing side by side.
- Door is not shown.
  - For white door order DOX-50014M and DOX-5008M
  - For red door order DOX-5014MR, and DOX-5008MR

# ANC-5000 Audio Network Controller Module

Figure 65: ANC-5000 Audio Network Controller board

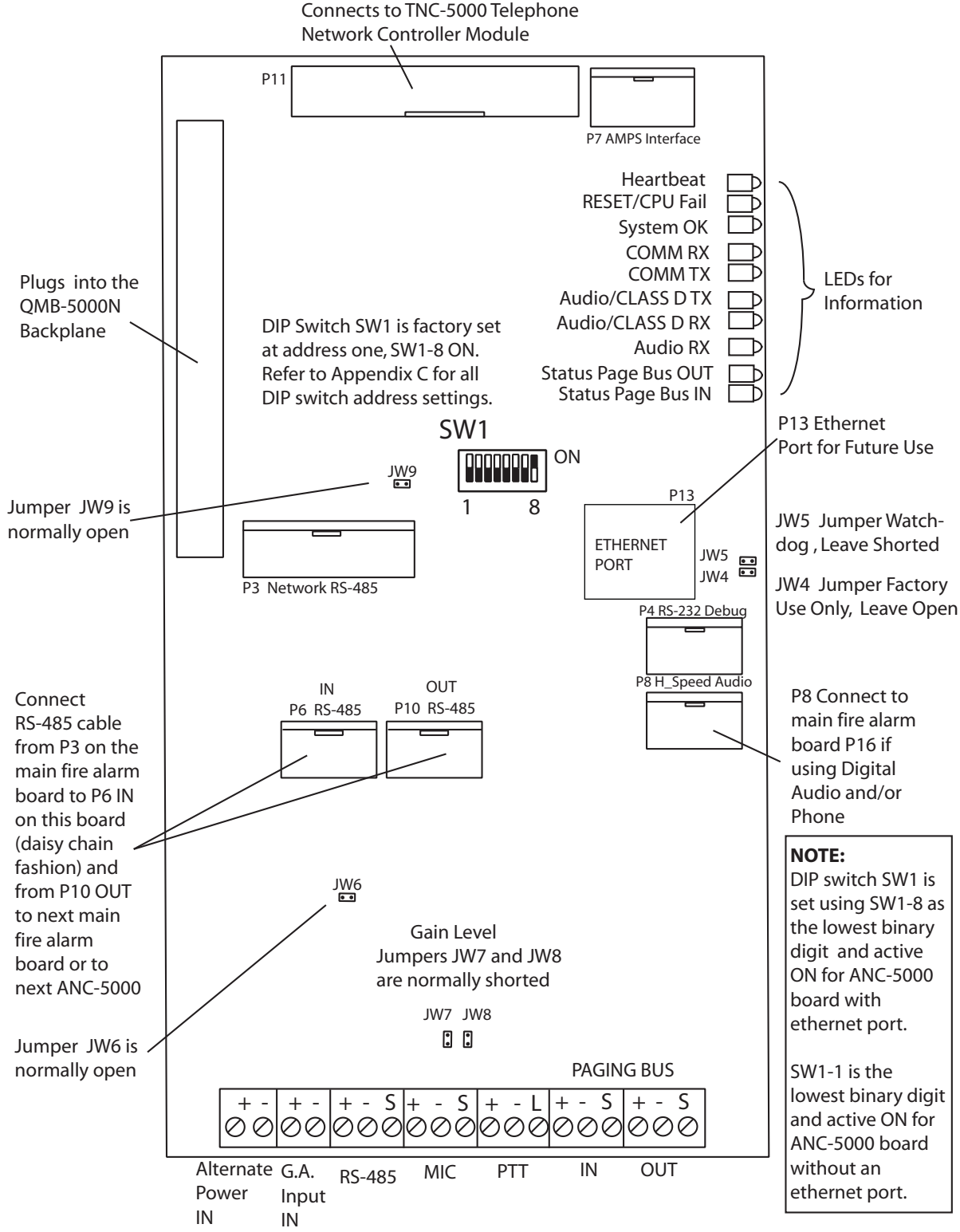

**NOTE: All connectors not shown on this drawing are for factory use only.**

# ANC-5000 Wiring

Figure 66: ANC-5000 Wiring Diagram

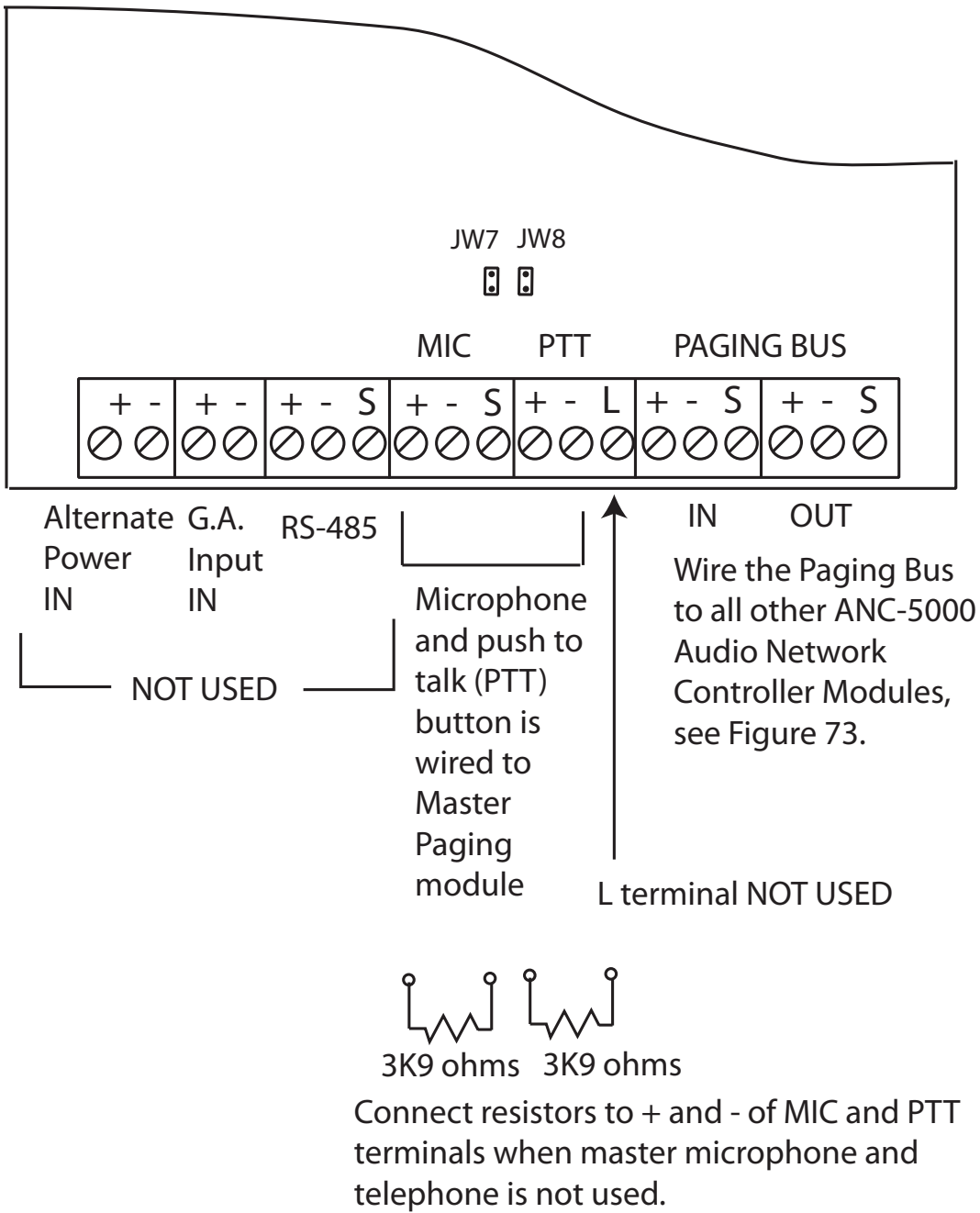
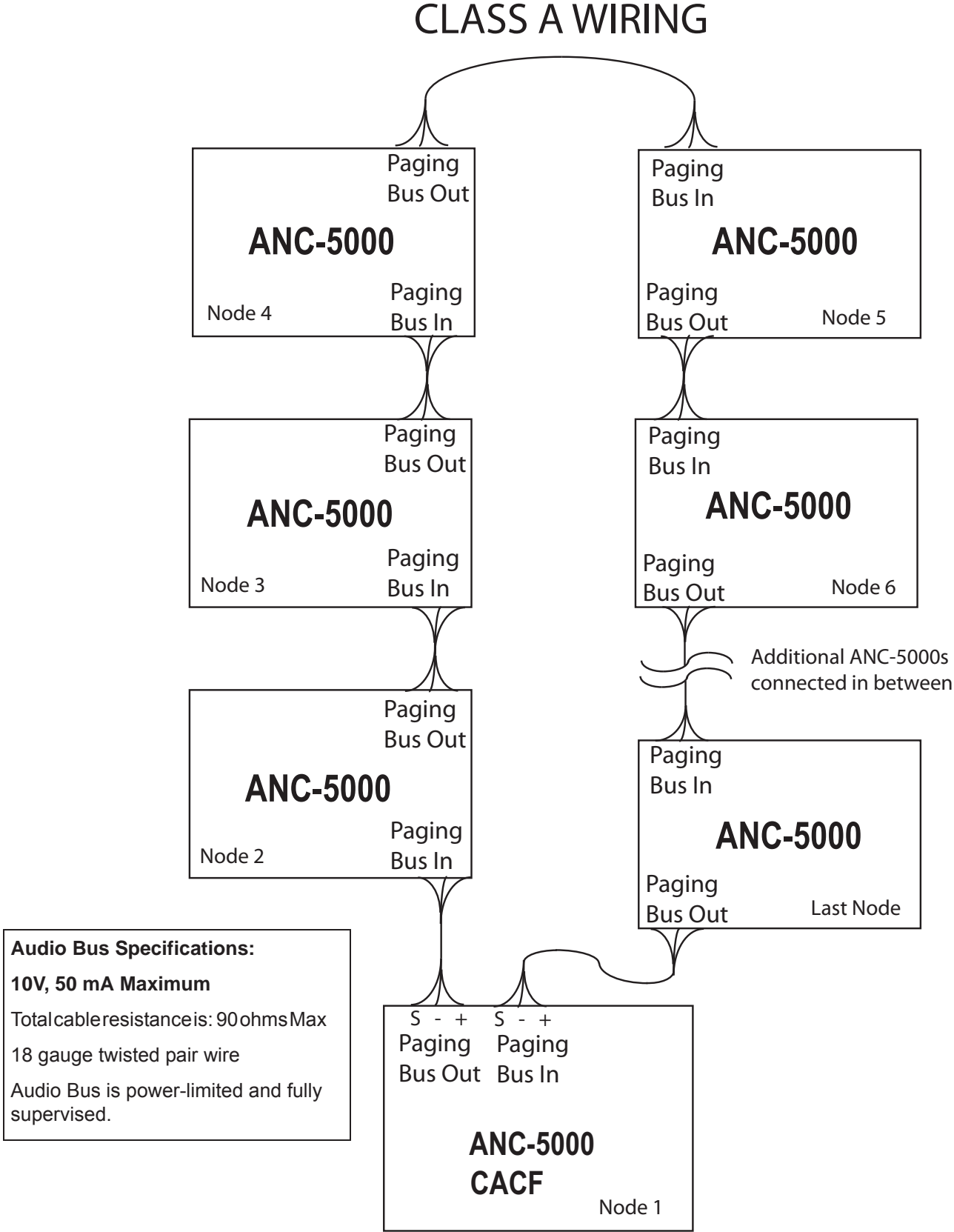



Figure 67: Audio Paging Bus Wiring



# QMP-5101NV Vertical Paging Control Module

The QMP-5101NV Paging Module fits into the new BBX-FXMNS Enclosure. It mounts on the inside dead chassis (part of the BBX-FXMNS). CONNECTIONS AND TERMINAL WIRING ARE THE SAME AS THE QMP-5101N, WIRE AS SHOWN IN THE FOLLOWING INSTRUCTIONS FOR QMP-5101N PAGING CONTROL MODULE.

**Figure 68: QMP-5101NV Vertical Paging Control Module**

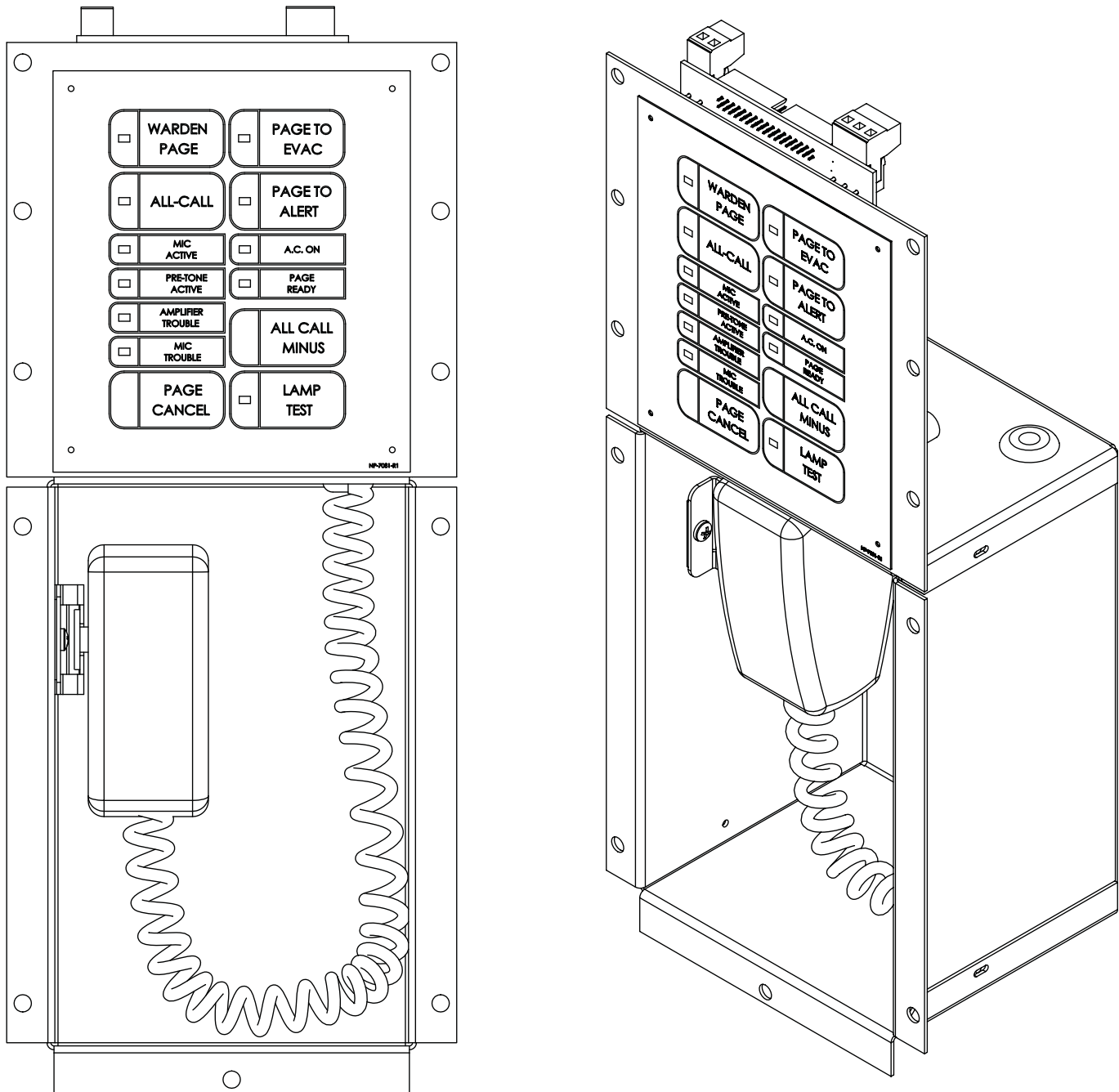

## Paging Modules

The QMP-5101N Network Master Paging Control Module mounts into the BB-5008 and BB-5014 backboxes.

### QMP-5101N Network Master Paging Control Module

The QMP-5101N Network Master Paging Control Module connects via a ribbon cable to the first QAZT-5302DS Zoned Selector Panel and to the previous display module. It also has wiring terminals for connection to the ANC-5000 Audio Network Controller Module in the cabinet

Slide-in labels NP-6659 are placed so that push buttons and LEDs are labelled as shown in Figure 75.

**Figure 69: QMP-5101N Network Master Paging Control Module**

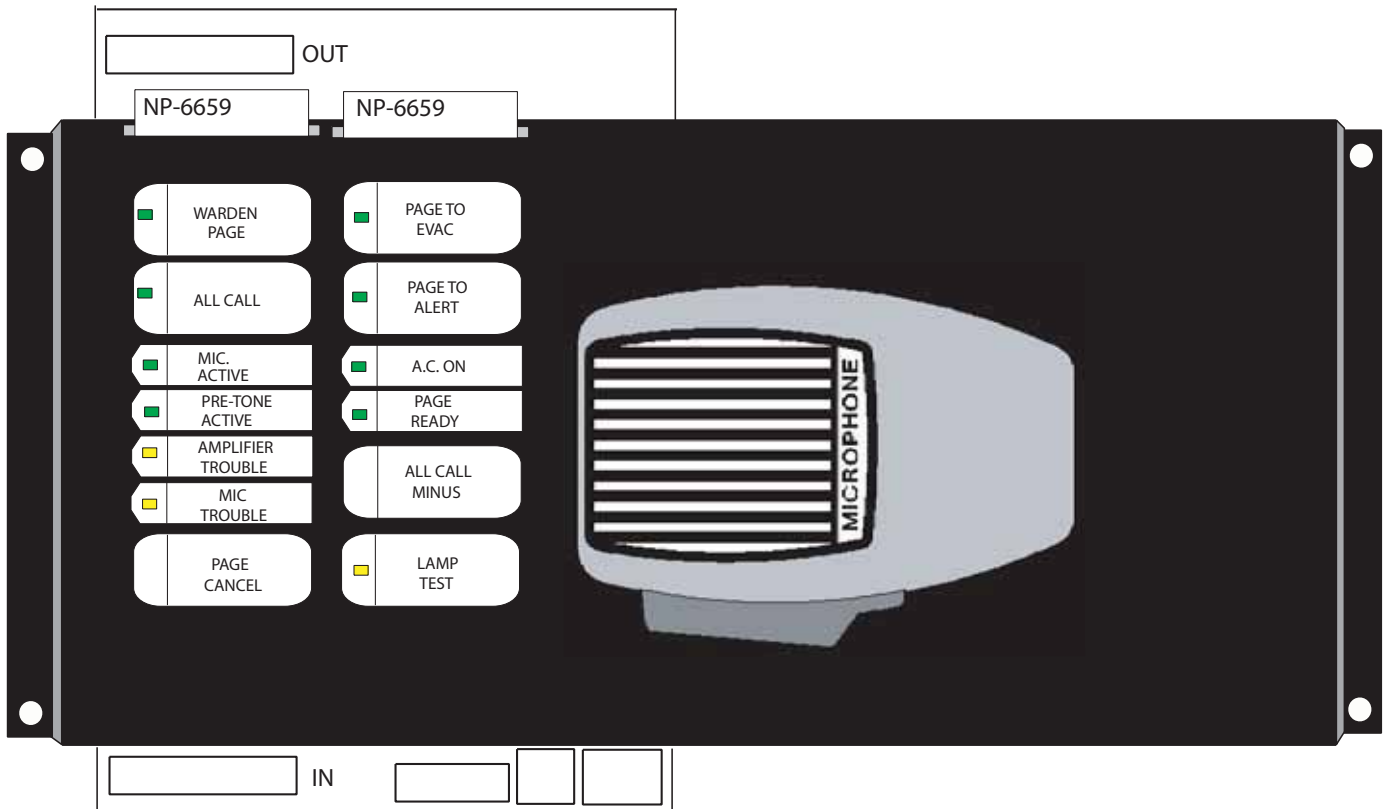

Connect ribbon cable from P1 (IN) to previous display module. Connect P2 (OUT) to the QAZT-5302DS Zoned Selector Panel or next display module. Wire the positive and negative terminals and the microphone MIC positive, negative and shield to the ANC-5000 Audio Network Controller Module corresponding terminals.

**Figure 70: QMP-5101N/V Network Master Paging Control Module Connections and Terminal Blocks**

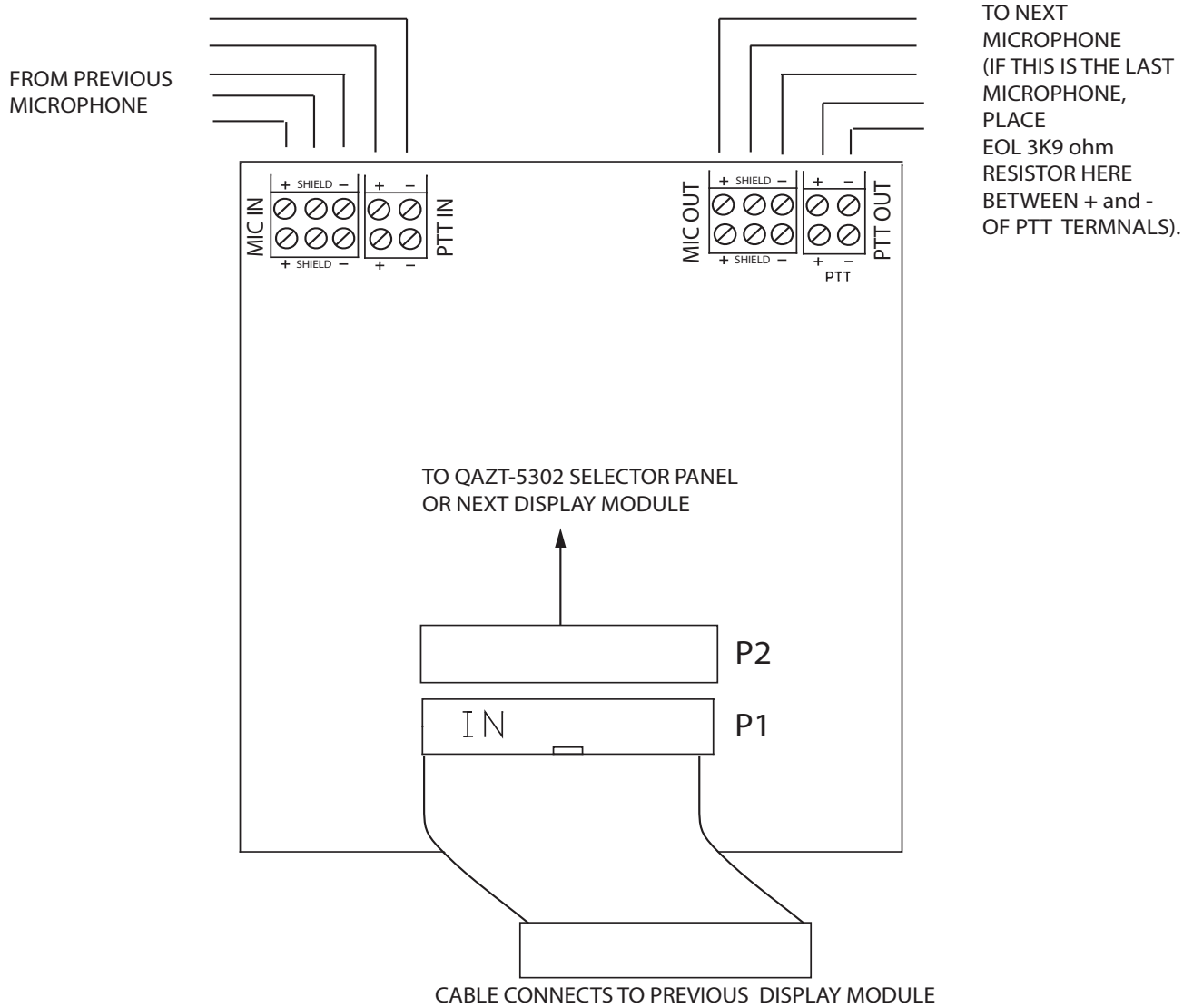

The interface wiring between the QMP-5101N and ANC-5000 is as follows:

|                          |                                 |
|--------------------------|---------------------------------|
| <b>MIC+, MIC-, SHLD:</b> | 18-22 AWG Twisted Shielded Pair |
| <b>PTT+, PTT-:</b>       | 18-22 AWG Twisted Pair          |

The maximum wiring run from the QMP-5101N and the ANC-5000 is 20 feet or 6 metres.

# QMP-5101N/V Network Paging Wiring

Figure 71: QMP-5101N/V Network Master Paging Control Module Wiring to the ANC-5000 Audio Network Controller Module

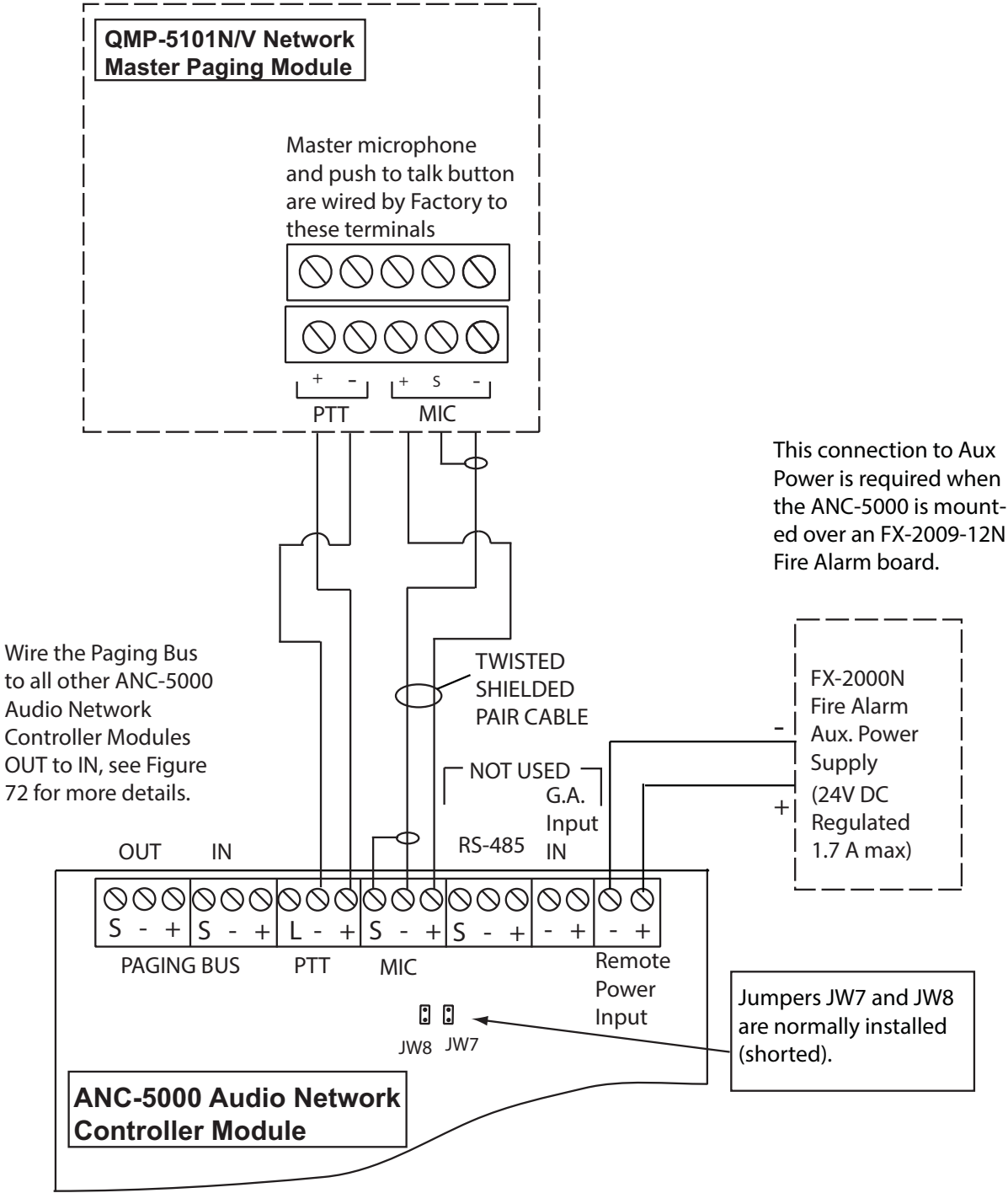

## QAZT-5302DS Zoned Paging Selector Panel

Each QAZT-5302DS annunciates and controls up to 24 audio zones. There is one button and two LEDs per zone. The lower amber LED indicates Zone trouble. The upper green LED indicates whether that zone is selected for voice paging via the master microphone.

Paging zone selection buttons toggle ON and OFF voice paging for that zone.

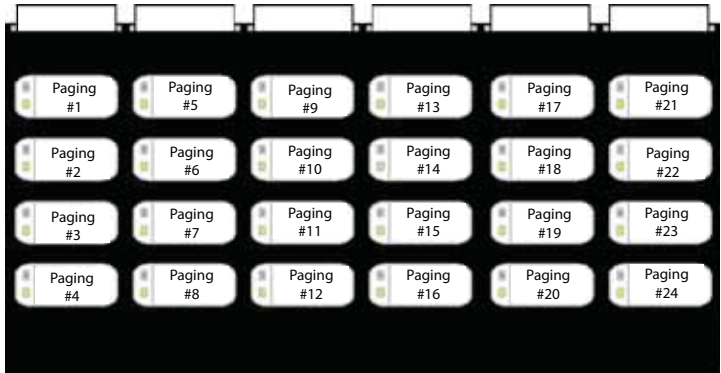

## Paging Operation

This section describes the controls and indicators on the QMP-5101N and QMP-5101NV Master Paging Control Modules and the QAZT-5302DS Paging Selector Modules.

### QMP-5101N/QMP-5101NV LEDs

#### Warden Page

Illuminates steady green to indicate that the Warden Page function is active.

#### All Call

Illuminates steady green to indicate that the All-Call function is active.

#### Mic Active LED

Flashes green to indicate any activity on the paging bus (i.e. other microphone in use). Illuminates steady green when associated microphone (at proximity of LED) is in use.

#### Pre-Tone Active LED

Steady green when paging and warden paging is active.

#### Amplifier Trouble LED

Indicates any amplifier internal trouble.

#### Mic Trouble LED

Flashes amber to indicate a microphone trouble.

#### Page to Evac LED

Illuminates steady green when the Page to Evac pushbutton is active.

#### Page to Alert LED

Illuminates steady green when the Page to Alert pushbutton is active.

#### AC ON LED

This green LED illuminates steadily to indicate that AC power is present.

#### Page Ready LED

Illuminates steady green when the push-to-talk (PTT) on the microphone is depressed (active).

#### Lamp Test LED

This amber LED illuminates steadily to indicate that the Lamp Test has been activated.

## QMP-5101N/QMP-5101NV Pushbutton Controls

### Warden Page Button

When depressed, the Warden Page button enables voice paging from the firefighters' telephone (if connected) to all zones selected for paging, unless page inhibit is active. Note that pressing PTT will not result in any paging activity unless there are zones selected for paging. Also note that there must be an active firefighters' telephone connection for warden paging to occur.

### All-Call Button

Selects all zones for voice paging.

### All-Call Minus Button

Inverts the selection of zones for voice paging.

### Page to Evac

Pressing this button selects all the audio zones currently in evacuation mode, for paging.

### Page to Alert

Pressing this button selects all the audio zones currently in alert mode, for paging.

### Page Cancel

Pressing this button de-selects all zones (including those manually selected) from paging.

### Lamp Test Button

Momentarily activates all LED indicators.

### Microphone PTT Button

The microphone's PTT (push-to-talk) button is located on the microphone itself. When depressed, allows voice paging (from the microphone) to be enabled to all zones selected for paging, unless page cancel is active. Note that pressing PTT will not result in any paging activity unless there are zones selected for paging.

## QAZT-5302/DS Paging Selector Panel LEDs

### Page LED

Illuminates green if the zone is selected for voice paging.

### Trouble LED

Flashes amber to indicate that the zone is in trouble.

## QAZT-5302/DS Pushbuttons

### Page Button (if enabled)

Selects / deselects that zone for voice paging.

# TNC-5000 Telephone Network Controller Module

## Module Mounting Locations

The TNC-5000 Telephone Network Controller board can be mounted in two places. The TNC-5000 Telephone Network Controller Board is mounted above (beside) the ANC-5000 Audio Network board, both are mounted on a metal backplate and the ANC-5000 plugs into slot 1 on the QMB-5000N audio backplane of the BBX-FXMNS, see 72. The other position is over the ANC-5000 Audio Network Controller module and both are mounted onto a metal plate and then the plate is mounted into a BB-5008 or BB-5014 backbox in positions marked 4 to 9 inclusive, refer to drawing of large chassis, 73

**Figure 72: Mechanical Installation of the TNC-5000 Telephone Network Controller Board within the BBX-FXMNS**

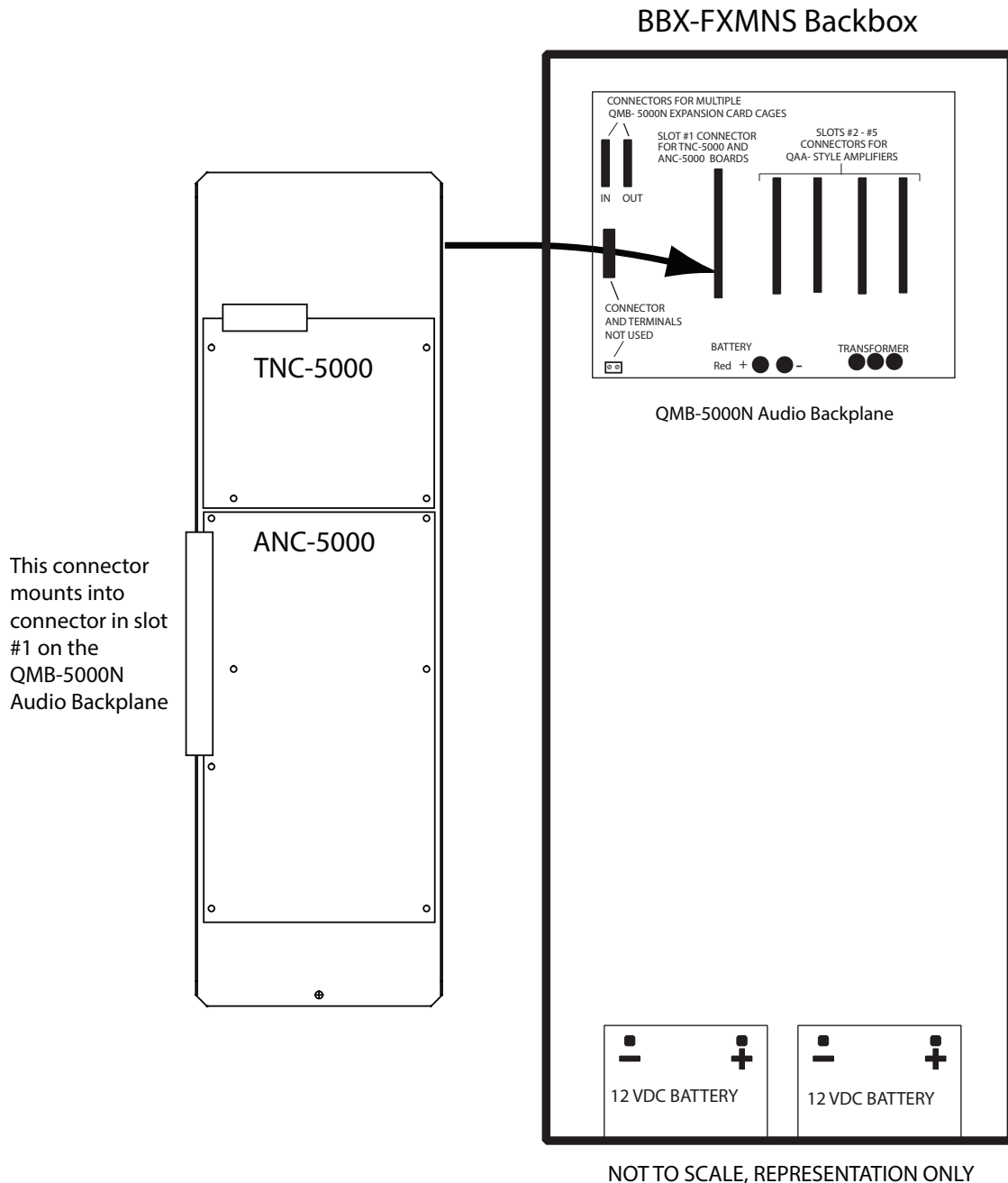



**Figure 73: Mechanical Installation of the TNC-5000 within the BB-5008 and BB-5014**

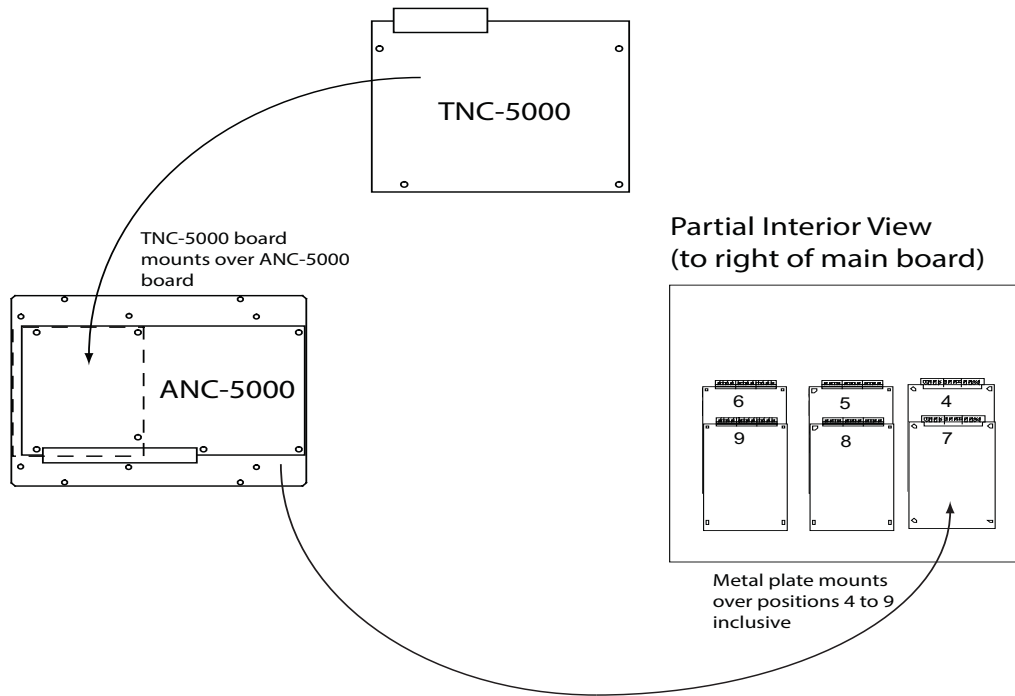

**Typical Addressable Telephone Set-up**

The typical addressable telephone set-up is with an addressable fire alarm system using the TNC-5000 and from the TNC-5000 to the Master Telephone (QMT-5302N/V). The selector panels (QAZT-5302DS) are connected to the Master Telephone by cable only. The MIX-M500FP(A) Control Modules are connected to the addressable loop from the FX-2000N and to each other and the Master Telephone. Remote telephones are connected to the control modules.

**Figure 74: Typical Addressable Telephone Set-up**

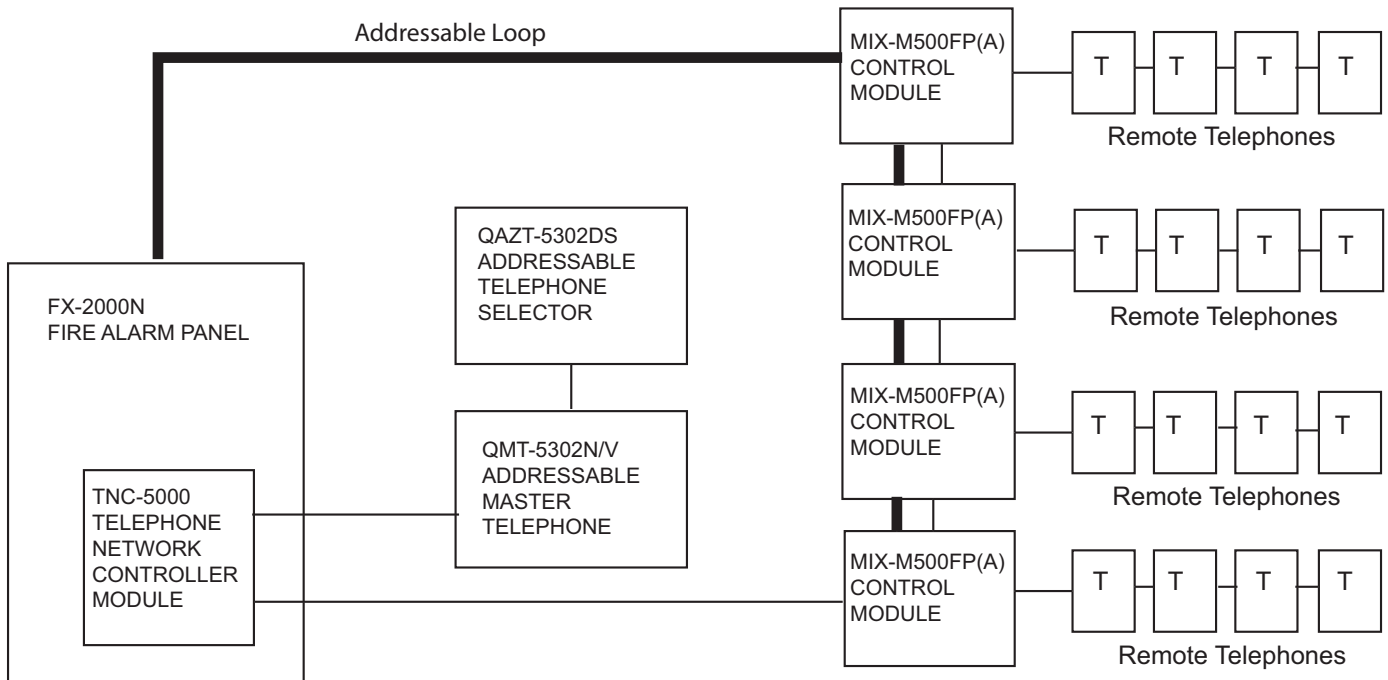

## Connectors and Terminal Locations

Refer to 75 for connector and terminal locations. Table 3 below shows the cable connections and jumpers required and additional wiring.

**Table 3: TNC-5000 Connectors and Terminals**

| TNC-5000 Connector and Terminals   | Connects to   |
|------------------------------------|---|
| P10 Cable                          | P11 on the ANC-5000 Audio Network Controller Module.  |
| Z1 Terminals                       | These two terminals are wired to the Master Telephone if used, otherwise to any telephone zone.   |
| Z2, Z3, Z4 and Z5 Terminals        | These terminals are wired to telephone zones.   |
| Telephone Bus In and Out Terminals | Wire from previous TNC-5000 to next TNC-5000. Total cable resistance is 50 ohms maximum, 18 gauge twisted pair. Telephone Bus is power limited and fully supervised |
| JW1                                | Jumper positions 1 and 2 if zone 1 is connected to a Master Telephone.  |
| JW1                                | Jumper positions 2 and 3 if zone 1 is NOT connected to a Master Telephone.  |

**Figure 75: TNC-5000 Telephone Network Controller Board Layout**

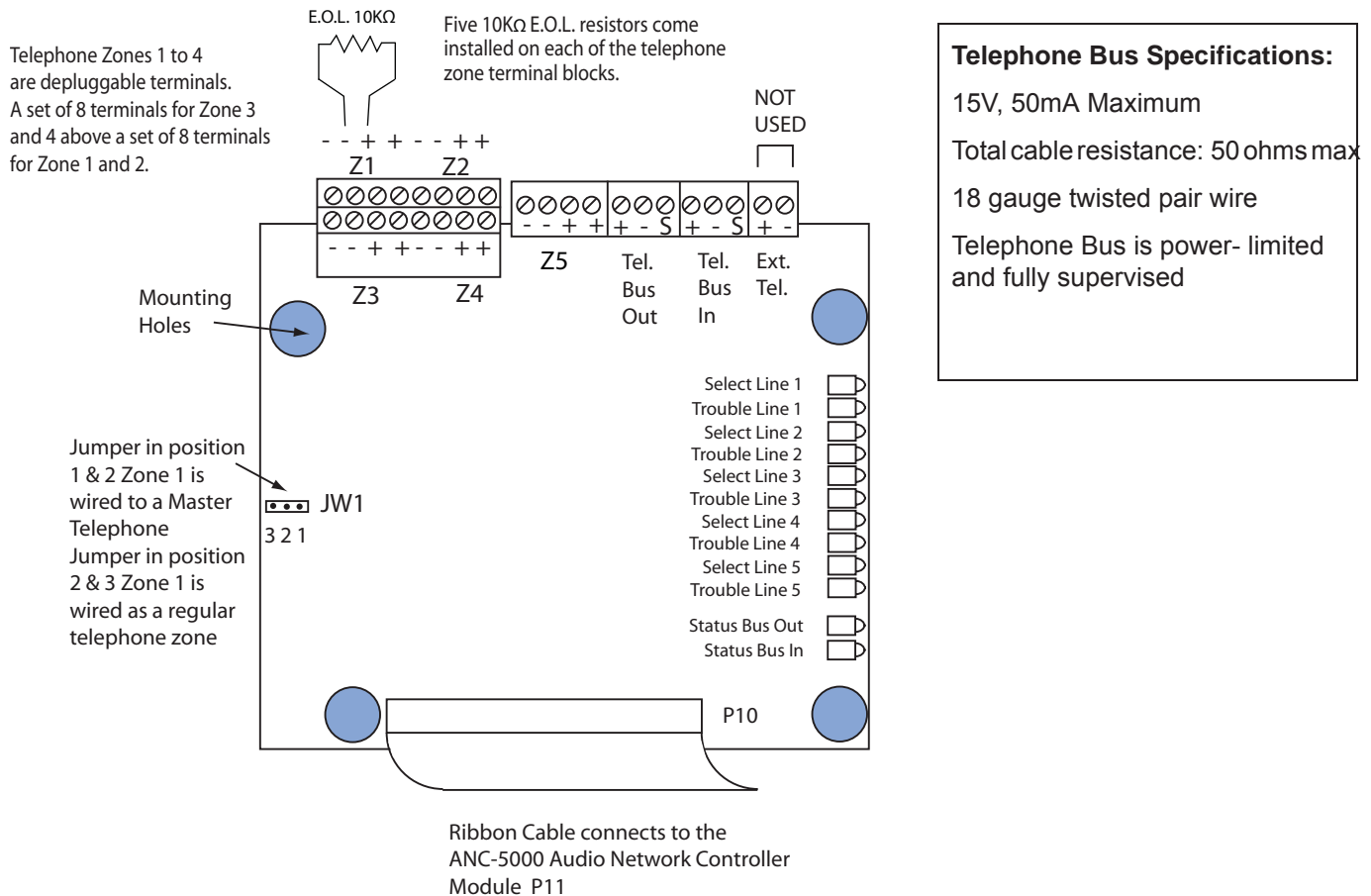

# TNC-5000 Telephone Wiring

Figure 76: Telephone Bus Wiring Diagram

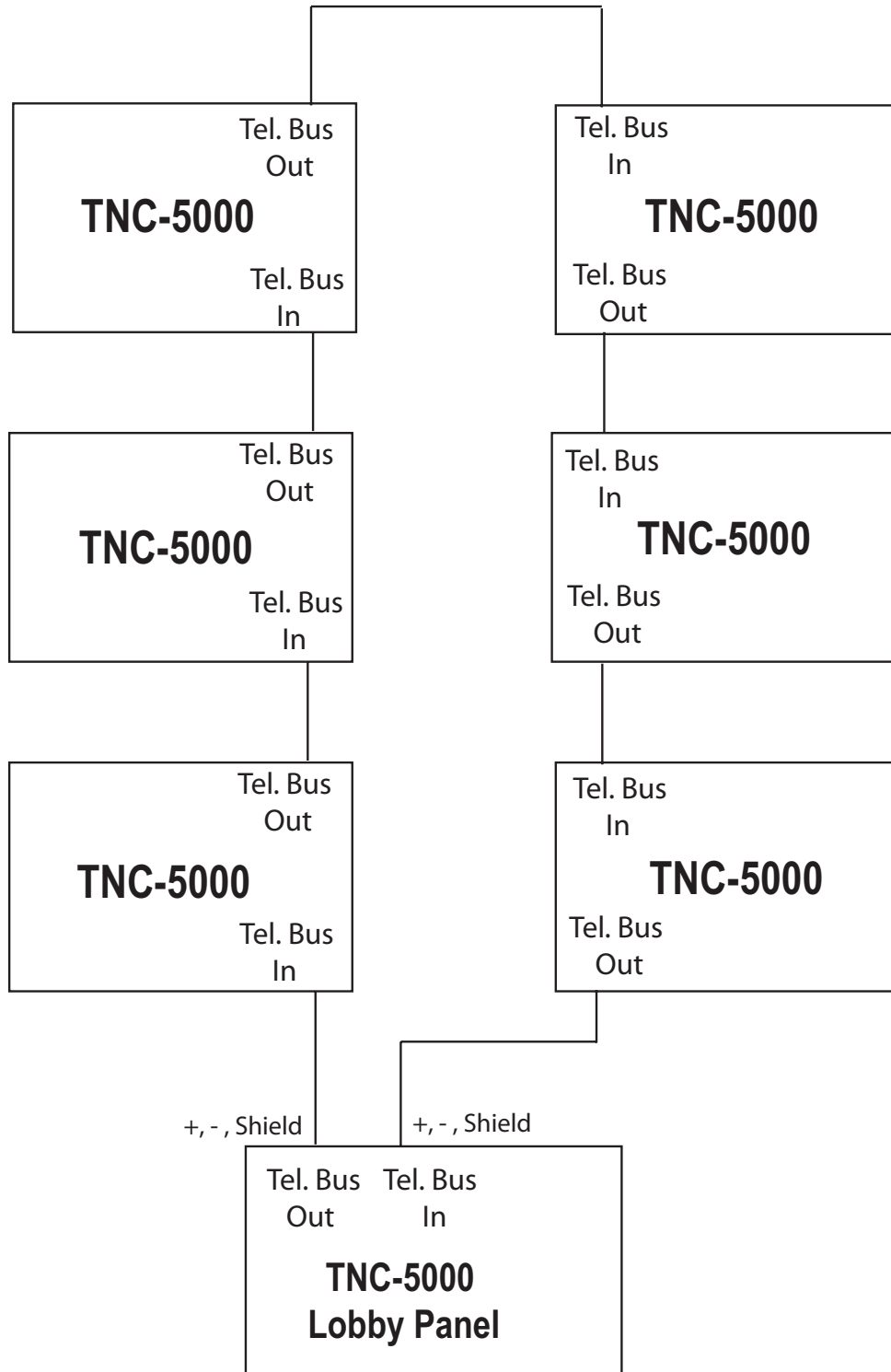

Zones 1 to 5 are wired to telephones via MIX-M500FP(A) addressable control modules. Only Zone 1 is wired to the

Master Telephone (if used) at the main fire alarm center, otherwise Zone 1 is wired as another telephone zone when a master telephone is not required.

**Figure 77: TNC-5000 Telephone Zone Wiring**

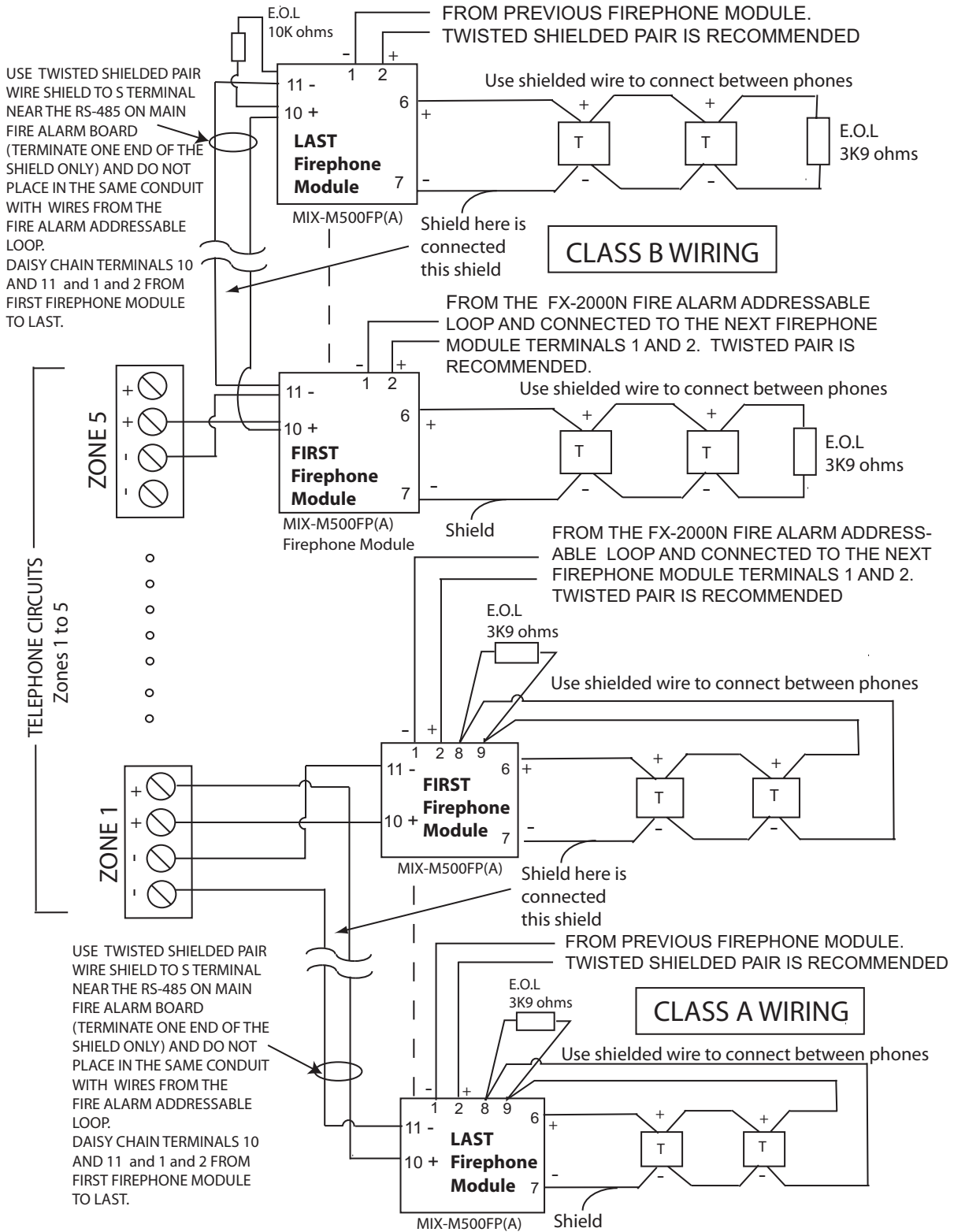

## QMT-5302NV Vertical Master Telephone

The QMT-5302NV Vertical Master Telephone Module fits into the new BBX-FXMNS Enclosure. The master telephone is mounted to the inside chassis and field wiring is on the BBX-FXMNS backbox. CONNECTIONS AND TERMINAL WIRING ARE THE SAME AS THE QMT-5302N, WIRE AS SHOWN IN THE FOLLOWING INSTRUCTIONS FOR QMT-5302N MASTER FIREFIGHTERS' TELEPHONE.

**Figure 78: QMT-5302NV Master Firefighters' Telephone**

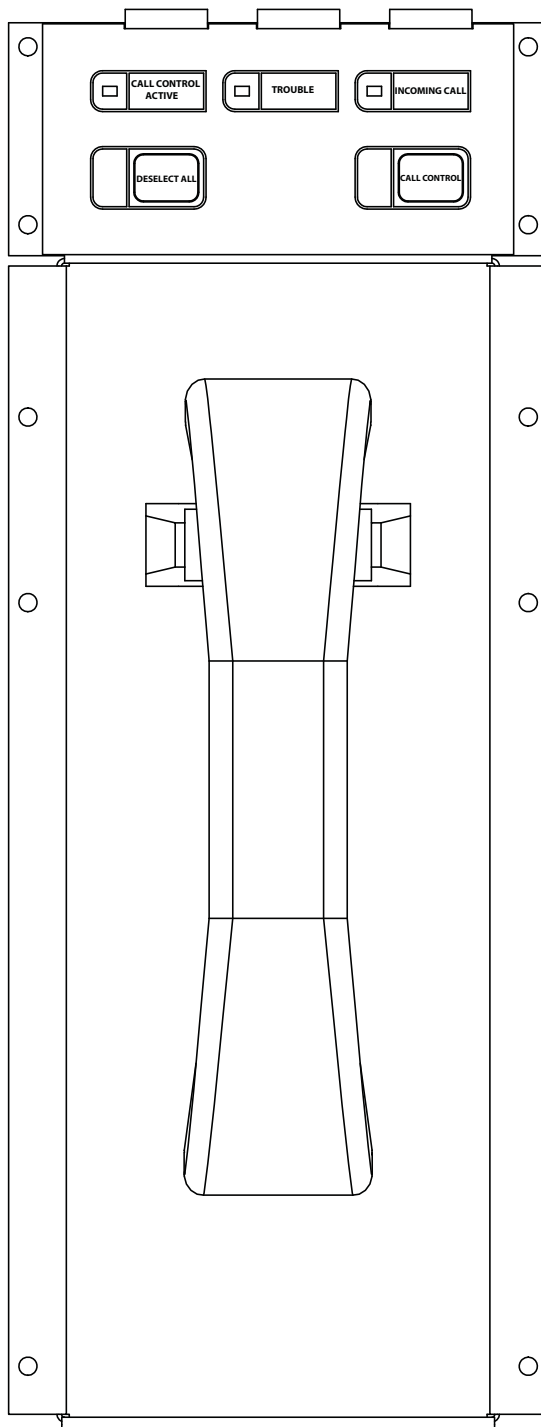

# QMT-5302N Master Firefighters' Telephone

The QMT-5302N mounts into the BB-5008 and BB-5014. QMT-5302N Network Master Firefighters' Telephone Control Module is used in conjunction with the Flex-Net™ Fire Alarm system at the CACF Node. Slide-in labels (NP-6657) are supplied with the Master Telephone. Place labels as shown in 79. The QAZT-5302DS Telephone Selector panels are used for selecting telephone zones (up to 24 zones per selector panel) and include blank labels for labelling the telephone zones.

**Figure 79: QMT-5302N Master Firefighters' Telephone**

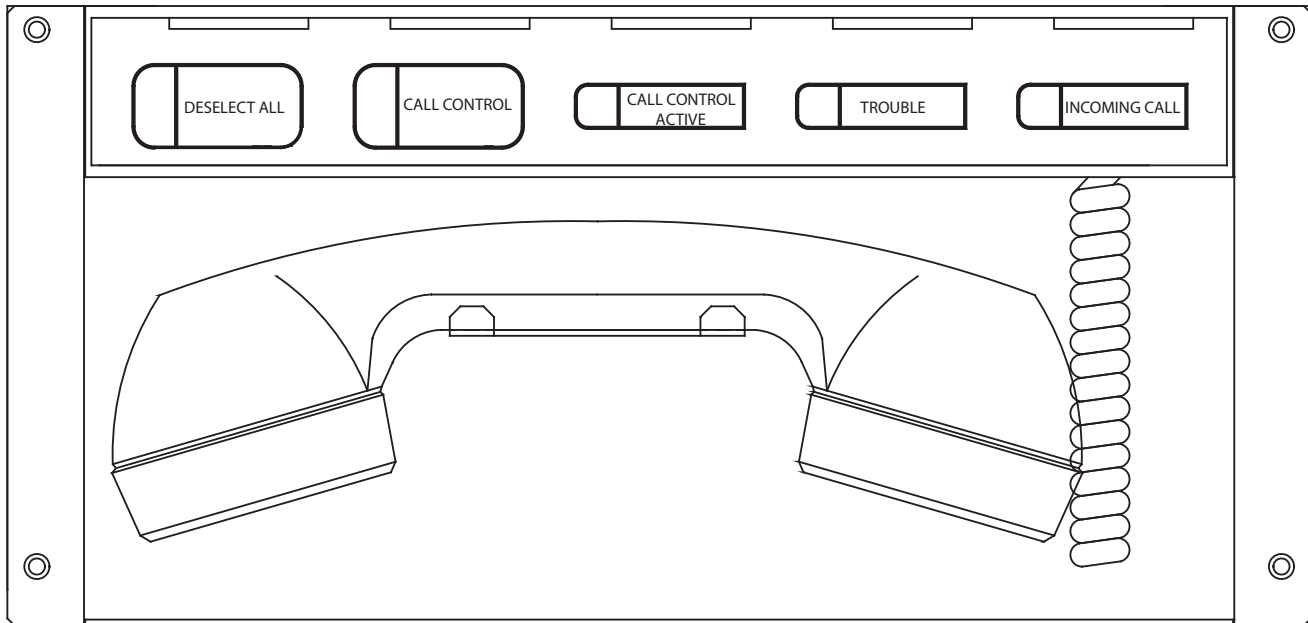

## QMT-5302N Connections

The connections required on the QMT-5302N Network Master Firefighters' Telephone Control Module are the cable from the previous display module to P1 or IN connector on the bottom left of the board and the OUT connection goes to the IN connector of the next display board.

The master telephone positive and negative terminals connect to the TNC-5000 Zone 1 positive and negative terminals with twisted shielded pair wires. Refer to 80 below for connector and terminal block locations of the QMT-5302N.

**Figure 80: QMT-5302N Cable Connection and Terminal Wiring**

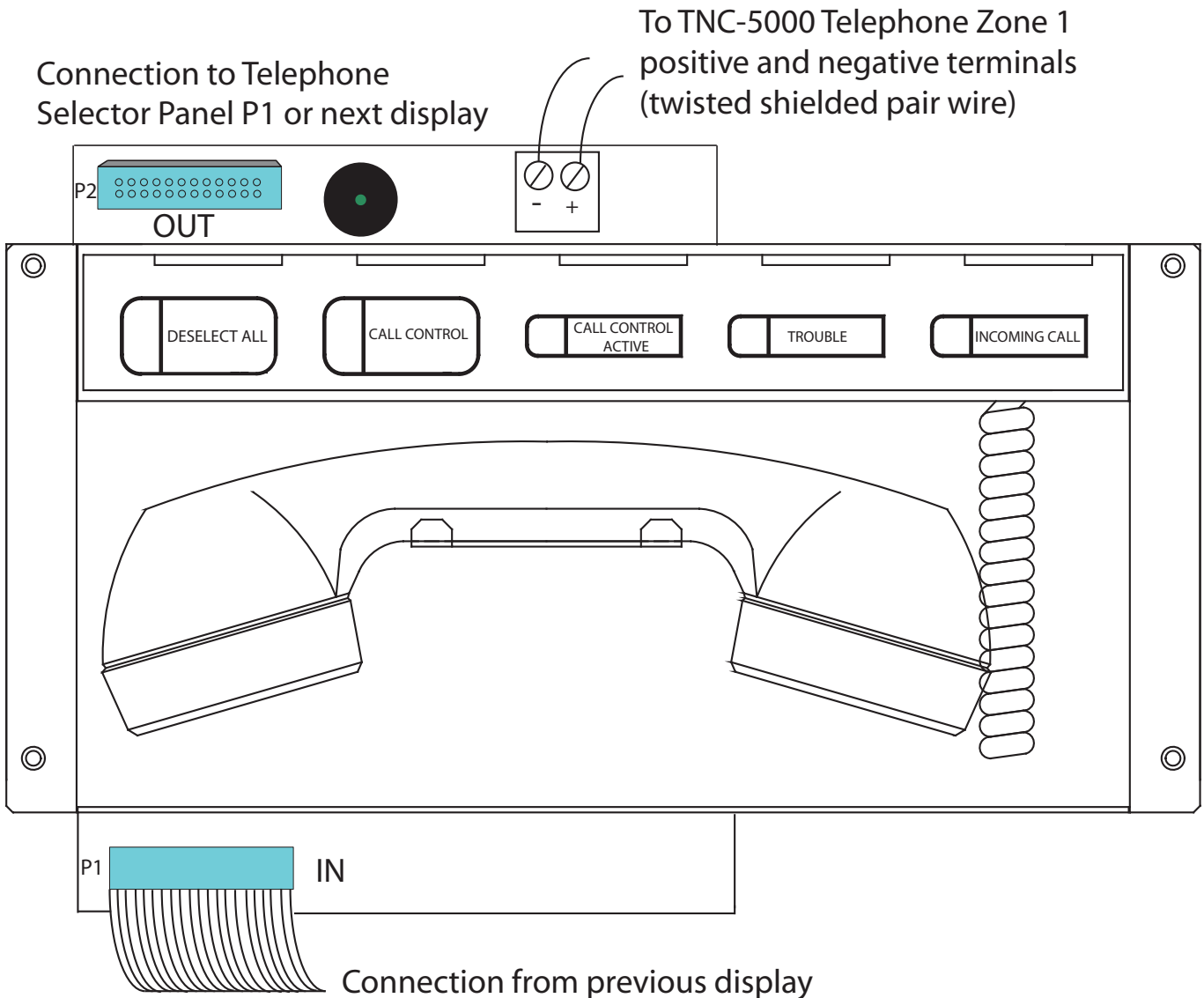

### Figure 81: QAZT-5302DS Network Firefighters' Telephone Selector Panel

Each QAZT-5302DS annunciates and controls up to 24 telephone zones. There is one button and two LEDs per zone. The lower amber LED indicates zone trouble. The upper green LED indicates whether that zone is selected for telephone communication.

Telephone zone selection buttons toggle ON and OFF telephone communication for that zone.

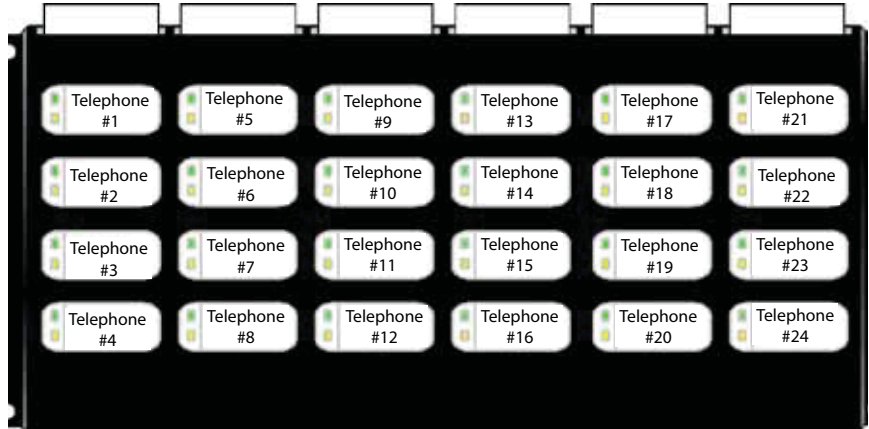

**Note:** Use configurator to set up the QAZT-5302DS Telephone Zone Selector Panels.

## QAZT-5302DS Network Firefighters' Telephone Selector Panel

Connect the first QAZT-5302DS Network Firefighters' Telephone Selector panel to the master telephone by connecting P1 cable into P2 on the QMT-5302N Master Telephone. P2 of the QAZT-5302DS is connected to P1 of the next display panel (up to six total).

### Figure 82: QAZT-5302DS Telephone Selector Board

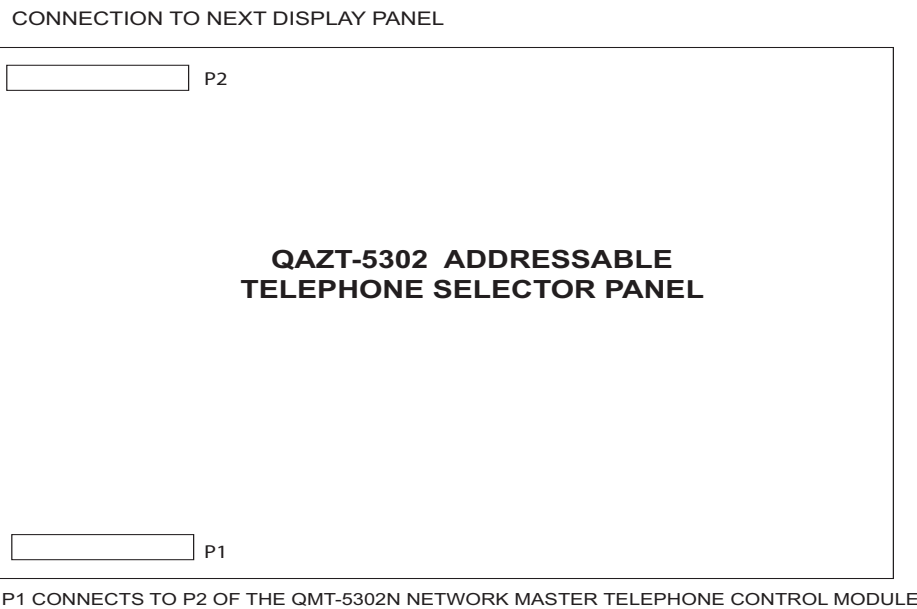

**Note:** All modules such as QMP-5101N/NV Network Master Paging Control Module, the QMT-5302N/NV Network Master Firefighters' Telephone Control Module, the IPS-2424DS display module and the paging or telephone selector panel QAZT-5302DS are daisy chained together starting from the FX-2000N LCD display module, DSPL-420, DSPL-2440, RAXN-LCD or RAXN-LCDG. Total number of boards allowed in the daisy chain connection is 6 (12 frames).



Connect the first QAZT-5302DS Network Firefighters' Telephone Selector panel to the master telephone by connecting the Ribbon In cable into P2 on the QMT-5302N/NV Master Telephone. Ribbon Out cable to the Ribbon In of the next QAZT-5302DS or P1 of the next display panel (up to six total). See diagram below.

QAZT-5302DS can be used as a telephone or paging selector panel by installing a jumper, see diagram below.

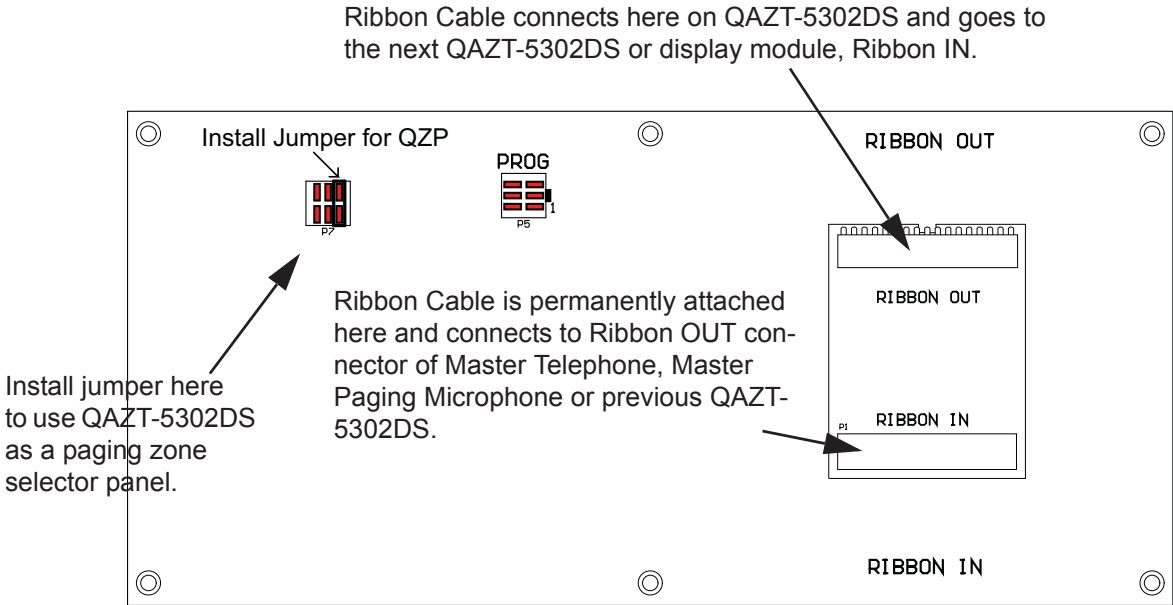

## Telephone Operation

---

1. When any telephone zone rings (the local buzzer sounds intermittently, and the green zone LED and Incoming Call LED flash) press that zone's button (on the selector panel QAZT-5302DS) once to answer. Once any one zone has been answered, calls from any other zone will cause that zone's green LED and the Incoming Call LED at the master telephone to flash and the buzzer will sound.
2. Press the answered zone's button once again to hang up. (Note that the telephone zone will hang up automatically if all handsets on the zone are placed back on the hook).

### QMT-5302N and QMT-5302NV Master Telephone LEDs

#### Trouble LED

This LED will flash amber if there is any zone or other trouble in the firefighters' telephone system.

#### Incoming Call LED

This LED will flash green if any telephone zone has a handset off-hook and unanswered. It will illuminate steady green if all telephone zones with off-hook handsets have been answered.

#### Call Control Active LED

This LED will illuminate when there is a connection between the designated Master Telephone (at the CACF) and the present QMT-5302N or QMT-5302NV telephone.

### QMT-5302N and QMT-5302NV Master Telephone Pushbutton Controls

#### Call Control

Pressing this pushbutton will connect this master telephone with master telephones as configured.

#### Deselect All

Pressing this pushbutton will disconnect all master telephone calls initiated at this node (Call Control minus).

### QAZT-5302DS Network Firefighters' Telephone Selector Panel LEDs

#### Telephone Zone Green LED

This LED will flash green if there is any handset off-hook on that zone, and the zone has not been answered by pressing the zone's button. Once answered, the LED will be steady green.

#### Telephone Zone Amber LED

This LED will flash amber to indicate trouble on open-circuit zone faults (e.g. missing end-of-line resistor or wire breaks) or short-circuit zone faults.

### QAZT-5302DS Network Firefighters' Telephone Selector Panel Pushbutton Controls

#### Telephone Selection Pushbutton

Pressing the telephone selector pushbutton will select the associated telephone to be connected to the Master Telephone. Pressing this button a second time will hang up.

# Appendix A: Specifications

|   |   |
|---|---|
| <p><b>Main Fire Alarm Chassis (FX-2003-12NDS)</b></p> <p><b>General</b></p> <p>One Analog Loop capable of monitoring 159 AP Sensors and 159 AP Modules.</p> <p><i>Power limited:</i> 22 VDC, 400 mA max, max loop resistance 40 ohms</p> <p><b>4 Style Y or Z</b> (Class B or A) Indicating Circuits; configurable as strobes or audibles. Terminals are labelled "IND".</p> <p><i>Power limited:</i> 24 VDC unfiltered, 1.7 A @ 49°C per circuit</p> <p><b>Displays (incl LCD) and Controls</b> for all Common Functions, and 16 Zone Displays.</p> <p><b>Optional PR-300 City Tie Module.</b></p> <p><b>Aux. Power Supply</b> (for Remote Annunciators). Terminals are labelled "AUX PWR".</p> <p><i>Power limited:</i> 24 VDC unfiltered, 1.7 A @ 49°C</p> <p><b>Resettable 4-Wire Smoke Supplies.</b> Terminals are labelled "4-WIRE".</p> <p><i>Power limited:</i> 22 VDC, 425 mA max., 5mV ripple</p> <p><b>One RS-485 Connection</b> for Remote Annunciators or interface to Audio Systems. Terminals are labelled "RS485".</p> <p><i>Power Limited</i> to 300 mA.</p> <p><b>Auxiliary relays:</b> (resistive loads)</p> <p>Must be connected to a Listed Power Limited Source of Supply. Terminals are labelled "ALARM, TROUBLE, SUPV".</p> <p>Common Alarm: Form C, 1 Amp, 24 VDC</p> <p>Common Supv: Form C, 1 Amp, 24 VDC</p> <p>Common Trouble: Form C, 1 Amp, 24 VDC</p> <p>Micro-controller based design.</p> <p>Fully Configurable with PC software.</p> <p>Full walk test function.</p> <p><b>Ground Impedance</b> 3k3 ohms</p> <p><b>Electrical Ratings</b></p> <p><i>AC Line Voltage:</i> 120V 60Hz / 240V, 50Hz</p> <p>4 Amps / 2 Amp (primary)</p> <p><i>Power Supply ratings:</i> 12 Amps. max. (secondary)</p> <p><i>For Indicating Circuits:</i> 24VDC unfiltered</p> <p>10 Amps. max.</p> <p><i>Battery:</i> 24VDC, Gel-Cell/Sealed Lead-Acid</p> <p><i>Charging capability:</i> 17-65 AH batteries</p> <p><i>Current Consumption:</i> standby: 310 mA</p> <p>alarm: 733 mA</p> | <p><b>Main Fire Alarm Chassis (FX-2017-12NDS)</b></p> <p><b>Same as FX-2003-12NDS except:</b></p> <p>Larger Chassis has capacity for 3 display modules and 17 adder modules.</p> <p><b>Main Fire Alarm Chassis (FX-2000MNS)</b></p> <p><b>Same as FX-2003-12NDS except:</b></p> <p><b>Displays (incl LCD) and Controls</b> for all Common Functions, and 16 Zone Displays <b>are not included.</b></p> <p><b>Quad Intelligent Analog Loop Module (ALCN-792M/D)</b></p> <p>Quad Analog Loops with additional ALCN-792D daughter board capable of monitoring 636 AP Sensors and 636 AP Modules.</p> <p><i>Power limited:</i> 22 VDC, 400 mA max, 10kHz frequency</p> <p>max loop resistance 40 ohms</p> <p><i>Current Consumption:</i> standby: 130 mA</p> <p>alarm: 145 mA</p> <p><b>Detection Adder Module (DM-1008A)</b></p> <p>Eight supervised Class B (Style B) or four Class A (Style D) initiating circuits; fully configurable. Terminals are labelled "INI". Initiating circuits are Compatibility ID "A".</p> <p><i>Current Consumption:</i> standby: 80 mA</p> <p>alarm: 1 zone active: 125 mA</p> <p>2 zone active: 170 mA</p> <p>4 zone active: 275 mA</p> <p>6 zone active: 370 mA</p> <p>8 zone active: 465 mA</p> <p><b>Signal Adder Module (SGM-1004A)</b></p> <p><b>Four Class B or A</b> (Style Y or Z) indicating circuits; configurable as strobes or audibles. Terminals are labelled "IND".</p> <p><i>Power Limited:</i> 24 VDC unfiltered</p> <p>max. 1.7 amps @ 49C per circuit</p> <p><i>Current Consumption:</i> standby: 60 mA</p> <p>alarm: 258 mA</p> <p><b>Relay Adder Module (RM-1008A) (resistive loads)</b></p> <p>Must be connected to a listed power limited source of supply. Terminals are labelled "RLY".</p> <p>Eight fully configurable Form C indicating.</p> <p>Form C, 1 amp., 28 VDC (resistive loads)</p> <p><i>Current Consumption:</i> standby: 25 mA</p> <p>alarm: 150 mA</p> |
| <p><b>Main Fire Alarm Chassis (FX-2009-12N/DS)</b></p> <p><b>Same as FX-2003-12N/DS except:</b></p> <p><b>Larger Chassis has capacity for 2 display modules and 9 adder modules.</b></p>  | <p><b>Polarity Reversal and City Tie Module (PR-300)</b></p> <p>Supervised city tie--not power limited</p> <p>24VDC unfiltered, 210 mA max., Trip coil: 14 ohms.</p> <p>Terminals are labelled "City Tie".</p> <p>Polarity reversal power limited</p> <p>Terminals are labelled "Polarity Reversal".</p> <p>24VDC open</p> <p>12VDC @ 3.5 mA, 8 mA max. (shorted)</p> <p><i>Current Consumption:</i> standby: 35 mA</p> <p>alarm: 300 mA</p>  |
| <p><b>FOM-2000-SP Fiber Optic Module</b></p> <p><i>Current Consumption:</i> standby: 15 mA</p> <p>alarm: 15 mA</p>  | <p><b>FNC-2000 Network Controller Module</b></p> <p><i>Current Consumption:</i> standby: 190 mA</p> <p>alarm: 190 mA</p>  |

|   |   |
|---|---|
| <b>ANC-5000 Audio Controller Module</b><br><i>Current Consumption:</i> standby: 255 mA<br>alarm: 265 mA   | <b>RAXN-LCDG Annunciator</b><br>24V DC nominal.<br>Standby: 117 mA Max., All LED's "On": 150 mA Max   |
| <b>TNC-5000 Telephone Controller Module</b><br><i>Current Consumption:</i> standby: 195 mA<br>alarm: 215 mA   | <b>RAXN-LCD Annunciator</b><br>24V DC nominal, range of 20 to 39V DC.<br>Standby: 100 mA Max., All LED's "On": 150 mA Max   |
| <b>Fan Damper Display Module (FDX-008/KI)</b><br>24V DC nominal, range of 20 to 39V DC.<br><i>Current Consumption:</i> standby: 15mA Max.<br>alarm (all LEDs ON): 35mA Max.                 | <b>Adder Annunciator Module RAX-1048/TZ/TZDS</b><br>48 Display Points (TZ version has 48 extra trouble display points).<br><i>Current Consumption:</i> standby: 139 mA<br>alarm: 1 zone LED active: 26 mA<br>2 zone LEDs active: 30 mA<br>3 zone LEDs active: 35 mA<br>4 zone LEDs active: 39 mA<br>48 zone LEDs active: 262 mA |
| <b>Selection Control Panel (FDS-008)</b><br>24V DC nominal.<br><i>Current Consumption:</i> standby: 24mA Max.<br>alarm (all LEDs ON): 112mA Max.  |   |
| <b>Digital Communicator Module (UDACT-300A)</b><br>Transmit alarm, supervisory, and trouble to a central monitoring station.<br><i>Current Consumption:</i> standby: 45 mA<br>alarm: 120 mA | <b>Programmable Input Switches Module (IPS-2424DS)</b><br><i>Current Consumption:</i> standby: 10/5 mA<br>alarm (one zone active): 15/22 mA   |
| <b>DSPL-420 and DSPL-2440 Displays</b><br><i>Current Consumption:</i> standby: 25mA and 35mA<br>alarm: 25mA and 30mA  |   |

## Compliance

**System Model:** Flex-Net™ Series Fire Alarm/Alarm Control Panels FX-2003-12NDS, FX-2009-12NDS, FX-2017-12NDS and FX-2000MNS.

**System Type:** Local, auxiliary (using PR-300), remote protected premise station (using PR-300 or UDACT-300A), central station protected premises (using UDACT-300A).

**Type of Service:** A, M, WF, SS (with PR-300 or UDACT-300A)

**Type of Signalling:** Non-coded

**Applicable Standards:** NFPA 70 and 72, UL-864, UL 2572, ULC S-524, ULC S-527

## ULI/ULC Integrated Fire Alarm and Audio Panel Specifications



**Note:** All circuits are power limited, unless specified otherwise.

### Overall

#### PS-2040 Power Supply

- 0 to 49 degrees Celsius, 0 to 93 + or - 2% RH (non-condensing) operating range
- Power input: 120 VAC, 60Hz, 12A or 240 VAC, 50Hz, 6A (primary), Not Power-limited
- Power supply ratings: 8.5A (x2), 18.85-0-18.85V (secondary)  
13A, 29V (secondary)

#### Model QPS-5000N & QBC-5000N Power Supply & Charger

- Primary input 120 VAC, 60Hz, or 240 VAC, 50HZ, 12Amp, Not Power-limited
- Charging for up to 65 AH of 24 VDC batteries
- Float Type Charger

#### Model FNC-2000 Fire Network Controller Module

- Current consumption: *standby:* 190mA  
*alarm:* 190mA

#### Model ANC-5000 Audio Network Controller Module

- Current consumption: *standby:* 255mA  
*alarm:* 265mA

#### Model TNC-5000 Telephone Network Controller Module

- Current consumption: *standby:* 195mA  
*alarm:* 215mA

#### Model FOM-2000-SP Fiber Optics Module

- Current consumption: *standby:* 15mA  
*alarm:* 15mA

#### Model QAA-5160-70/25 Amplifier with one 70V or 25V, 60 Watt Zone

- 70.7Vrms or 25V constant voltage output
- One fully supervised Class "A" or "B" speaker Zone
- 60 watts per zone
- Freq. Response: ULI bandwidth from 800 to 2800 Hz
- Harmonic distortion less than 2.5% at 1 KHz
- Current consumption: *standby:* 55mA  
*alarm:* 350mA, plus 65mA/Watt Speaker Power

#### Model QAA-5230-70/25 Amplifier with two 70V or 25V, 30 Watt Zones

- 70.7Vrms or 25V constant voltage output
- Two fully supervised Class "A" or "B" speaker zones
- 30 watts per zone
- Freq. Response: ULI bandwidth from 800 to 2800 Hz
- Harmonic Distortion less than 2.5% at 1 KHz
- Current Consumption: *standby:* 55mA  
*alarm:* 350mA, plus 65mA/Watt Speaker Power

**Model QAA-5230S-70/25 Amplifier with 2 split 70V or 25V, 30 Watt Zones**

- 70.7Vrms or 25V constant voltage output
- Each 30W output divided into 2 Class "B" 15W lines for split speaker line applications (two lines per zone with staggered speakers); four fully supervised Class "B" speaker zones
- 30 watts per zone, 15 Watts per split
- Freq. response: ULI bandwidth from 800 to 2800 Hz
- Harmonic Distortion less than 2.5% at 1 KHz
- Current Consumption: *standby*: 55mA  
*alarm*: 350mA, plus 65mA/Watt Speaker Power

**Model QAA-5415-70 Amplifier with four 70V, 15 Watt Zones**

- 70.7Vrms constant voltage output
- Four fully supervised Class "B" speaker zones, 15 watts per zone
- Freq. response: ULI bandwidth from 800 to 2800 Hz
- Harmonic distortion less than 2.5% at 1 KHz
- Current consumption: *standby*: 55mA  
*alarm*: 350mA, plus 75mA/watt speaker power

**Model QAA-5415-25 Amplifier with four 25V, 15 Watt Zones**

- 25Vrms constant voltage output
- Four fully supervised Class "B" speaker zones
- 15 watts per zone
- Freq. response: ULI bandwidth from 800 to 2800 Hz
- Harmonic distortion less than 2.5% at 1 KHz
- Current consumption: *standby*: 55mA  
*alarm*: 350mA, plus 75mA/watt speaker power

**Model QMP-5101N or QMP-5101NV Paging Microphone**

- Mounts in Mircom BB-1000, BB-5000, FX-LOC, and BBX-FXMNS (for QMP-5101NV) enclosures
- Current Consumption: *standby*: 3mA  
*alarm*: 7mA

**Model QAZT-5302/DS Paging Selector Panel**

- Mounts in Mircom BB-1000, BB-5000 and BBX-FXMNS enclosures
- Connects to QMP-5101N to provide 24 zones of paging control
- Up to one per QMP-5101N or QMP-5101NV
- Current Consumption: *standby*: 10mA  
*alarm*: 15mA

**Model QMT-5302N or QMT-5302NV Master Telephone**

- Mounts in Mircom BB-1000, BB-5000, FX-LOC, and BBX-FXMNS enclosures
- Current Consumption: *standby*: 1mA  
*alarm*: 13mA

**Model QAZT-5302DS Telephone Selector Panel**

- Mounts in Mircom BB-1000, BB-5000, FX-LOC, and BBX-FXMNS enclosures
- Connects to QMT-5302N to provide 24 firefighters' telephone zones
- Up to six selector panels per QMT-5302N
- Unlimited handsets allowed per telephone circuit, supports up to 5 handsets active at the same time
- Current Consumption: *standby*: 10mA/5mA  
*alarm*: 15mA/22mA

## Appendix B: Power Supply and Battery Calculations

| Model Number   | Description                         | Qty |   | Standby     | Total Standby | Alarm   | Total Alarm |
|--|-------------------------------------|-----|---|-------------|---------------|---|-------------|
| FX-2003-12NDS  | Main Chassis (12 Amp)               |     | X | 0.310       | =             | 0.733   | =           |
| FX-2017-12NDS  | Main Chassis (12 Amp)               |     | X | 0.310       | =             | 0.733   | =           |
| FX-2009-12NDS  | Large Main Chassis (12 Amp)         |     | X | 0.310       | =             | 0.733   | =           |
| ALCN-792M  | Dual Analog Loops                   |     | X | 0.130       | =             | 0.145   | =           |
| ALCN-792M/D  | Quad Analog Loops                   |     | X | 0.130       | =             | 0.145   | =           |
| FNC-2000   | Fire Network Controller Module      |     | X | 0.190       | =             | 0.190   | =           |
| ANC-5000   | Audio Network Controller Module     |     | X | 0.255       | =             | 0.265   | =           |
| TNC-5000   | Telephone Network Controller Module |     | X | 0.195       | =             | 0.215   | =           |
| FOM-2000-SP  | Fiber Optics Module                 |     | X | 0.015       | =             | 0.015   | =           |
| DM-1008A   | 8 Initiating Circuit Module         |     | X | 0.080       | =             | 1 zone active: 0.125<br>2 zone active: 0.170<br>4 zone active: 0.275<br>6 zone active: 0.370<br>8 zone active: 0.465  | =           |
| SGM-1004A  | 4 Indicating Circuit Module         |     | X | 0.060       | =             | 0.258   | =           |
| RM-1008A   | 8 Relay Circuit Module              |     | X | 0.025       | =             | 0.150   | =           |
| FDX-008/KI   | Fan Damper Control Module           |     | X | 0.015       | =             | 0.035   | =           |
| DSPL-420   | Narrow Display                      |     | X | 0.025       | =             | 0.025   | =           |
| DSPL-2440  | Graphic Display                     |     | X | 0.029       | =             | 0.035   | =           |
| UDACT-300A   | Dialer Module                       |     | X | 0.045       | =             | 0.120   | =           |
| PR-300   | City Tie Module                     |     | X | 0.035       | =             | 0.300   | =           |
| FDS-008  | Selection Control Panel for MNS     |     | X | 0.024       | =             | 0.112   | =           |
| RAX-1048TZDS   | Adder Annunciator Chassis           |     | X | 0.022       | =             | 1 zone active: 0.026<br>2 zone active: 0.030<br>3 zone active: 0.035<br>4 zone active: 0.039<br>48 zone active: 0.262 | =           |
| RAM-1032TZDS   | Adder Annunciator Chassis           |     | X | 0.050       | =             | 32 zone active: 0.300   | =           |
| AGD-048  | Adder Graphic Driver Board          |     | X | 0.035       | =             | __(#of LEDs) x 4mA<br>(Refer to LT-847 if using lamps)  | =           |
| IPS-2424DS   | Programmable Input Switches Module  |     | X | 0.010/0.005 | =             | 0.015/0.022   | =           |
| Two-Wire Smoke Detectors                             |                                     |     | X | ♦ 0.00005   | =             | *0.39   | = 0.39      |
| MIX-1251B/BA Analog Ion Smoke Detector               |                                     |     | X | 0.0003      | =             | 0.0065  | =           |
| MIX-2251B/BA Analog Photo Smoke Detector             |                                     |     | X | 0.0003      | =             | 0.0065  | =           |
| MIX-2251TMB/TMBA Analog Thermal Sensor               |                                     |     | X | 0.0003      | =             | 0.0065  | =           |
| MIX-M500MB/MA, MIX-M501MB/MA Monitor                 |                                     |     | X | 0.0004      | =             | 0.0051/0.0055   | =           |
| MIX-M500R(A)/MIX-M500S(A) Addressable Control Module |                                     |     | X | 0.0003      | =             | 0.0051  | =           |
| MIX-M500X(A) Fault Isolator Module                   |                                     |     | X | 0.00045     | =             | 450µA   | =           |
| B224BI(A) Analog Base with Isolator                  |                                     |     | X | 0.00045     | =             | 0.005   | =           |
| Four-Wire Smoke Detectors                            |                                     |     | X |             | =             |   | =           |
| Signal Load (bells, horns, strobes, and etc.)        |                                     |     | X |             | =             |   | =           |
| Auxiliary Power Supply for Remote Annunciators       |                                     |     |   |             | =             |   | =           |
| Total currents (Add above currents)                  |                                     |     |   | STANDBY     | (A)           | Alarm   | (B)         |

Battery Calculations continued. . . .

Legend: \* Assuming three initiating circuits in alarm.

♦ Using the **2W-B or C2W-BA** 2-wire smoke detector. See LT-1023 Compatibility List for other compatible smoke detectors.

**To Calculate Chassis and Battery Size:**

Add all the alarm currents in column (B), and use this value to determine main chassis selection and the battery capacity requirement.

**Total Current Requirement:** ALARM (total from column **B**) \_\_\_\_\_ Amps.

**Main Chassis Selection:**

Select **FX-2003-12NDS**, **FX-2017-12NDS** or **FX-2009-12NDS** if the total of column **B** is less than 12 Amps.

Use the total from column (A) as the standby current required. Multiple this value by 24 hours or 60 hours depending on AHJ. Add this total to the total of column (B) multiplied by the time in hours to sustain alarm.

\* Use **0.084** for five minutes of alarm or **0.5** for thirty minutes of alarm as a multiplier figure.

**Battery Capacity Requirement:**

$$([\text{STANDBY (A) } \_\_\_\_\_\_] \times [(24 \text{ or } 60 \text{ Hours) } \_\_\_\_\_\_] + ([\text{ALARM (B) } \_\_\_\_\_\_] \times [* \text{Alarm in Hr.}] \_\_\_\_\_\_)) = (\text{C}) \_\_\_\_\_\_ \text{AH}$$

**Battery Selection:** Multiply (total from column **C**) by 1.20 to derate battery.

- Batteries:** BAT-12V18 (18AH) will fit in the BBX-1024DS  
 BA-12V26 (26AH) will fit in the BBX-1072A/DS, BB-5008, or BB-5014  
 BA-12V42 (42AH) will fit in the BC-160 battery cabinet

**RAXN-LCD/RAXN-LCDG:**

The RAXN-LCD Remote Shared Display is a remote annunciator that provides the same functions as the main display on the fire alarm control panel, less 16 zone LEDs. The RAXN-LCDG is similar to the RAXN-LCD except its display is a graphical LCD. It is equipped with expanded memory of more than 18,000 system points, large 4 line x 20 character backlit alphanumeric LCD display (or for the RAXN-LCDG a graphical display) which uses a simple menu system complete with a directional key pad and switches for Enter, Menu, Cancel and Info. For more information see Mircom documents LT-895 and LT-6033.

**Models:**

- **RAXN-LCD or RAXN-LCDG** Main Annunciator Chassis with Common Indicators and Controls.
- **RAX-1048TZDS:** Adder Annunciator Chassis with 48 Circuit Capacity.
- **IPS-2424DS:** Programmable Input Switches module with 48 display points and 24 buttons.

**ENCLOSURES for RAXN-LCD and RAXN-LCDG:**

- **BB-1001** With capacity for one Annunciator Chassis.
- **BB-1002** With capacity for two Annunciator Chassis.
- **BB-1003** With capacity for three Annunciator Chassis.
- **BB-1008** With capacity for eight Annunciator Chassis.
- **BB-1012** With capacity for twelve Annunciator Chassis.



**Notes:**

- **Finish:** Painted, textured, off-white (standard) (for other paint available colours and finishes, please contact factory)
- **Material:** 18 G.A. cold roll steel (CRS)



# Appendix C: DIP Switch Settings

## FX-200X-XX Network Main Board Address Setting (DIP SWITCH SW2)

| Node Address | SW2 DIP SWITCHES |       |       |       |       |       |       |       |
|--------------|------------------|-------|-------|-------|-------|-------|-------|-------|
|              | SW2-1            | SW2-2 | SW2-3 | SW2-4 | SW2-5 | SW2-6 | SW2-7 | SW2-8 |
| 1            | ON               | OFF   | OFF   | OFF   | OFF   | OFF   |       |       |
| 2            | OFF              | ON    | OFF   | OFF   | OFF   | OFF   |       |       |
| 3            | ON               | ON    | OFF   | OFF   | OFF   | OFF   |       |       |
| 4            | OFF              | OFF   | ON    | OFF   | OFF   | OFF   |       |       |
| 5            | ON               | OFF   | ON    | OFF   | OFF   | OFF   |       |       |
| 6            | OFF              | ON    | ON    | OFF   | OFF   | OFF   |       |       |
| 7            | ON               | ON    | ON    | OFF   | OFF   | OFF   |       |       |
| 8            | OFF              | OFF   | OFF   | ON    | OFF   | OFF   |       |       |
| 9            | ON               | OFF   | OFF   | ON    | OFF   | OFF   |       |       |
| 10           | OFF              | ON    | OFF   | ON    | OFF   | OFF   |       |       |
| 11           | ON               | ON    | OFF   | ON    | OFF   | OFF   |       |       |
| 12           | OFF              | OFF   | ON    | ON    | OFF   | OFF   |       |       |
| 13           | ON               | OFF   | ON    | ON    | OFF   | OFF   |       |       |
| 14           | OFF              | ON    | ON    | ON    | OFF   | OFF   |       |       |
| 15           | ON               | ON    | ON    | ON    | OFF   | OFF   |       |       |
| 16           | OFF              | OFF   | OFF   | OFF   | ON    | OFF   |       |       |
| 17           | ON               | OFF   | OFF   | OFF   | ON    | OFF   |       |       |
| 18           | OFF              | ON    | OFF   | OFF   | ON    | OFF   |       |       |
| 19           | ON               | ON    | OFF   | OFF   | ON    | OFF   |       |       |
| 20           | OFF              | OFF   | ON    | OFF   | ON    | OFF   |       |       |
| 21           | ON               | OFF   | ON    | OFF   | ON    | OFF   |       |       |
| 22           | OFF              | ON    | ON    | OFF   | ON    | OFF   |       |       |
| 23           | ON               | ON    | ON    | OFF   | ON    | OFF   |       |       |
| 24           | OFF              | OFF   | OFF   | ON    | ON    | OFF   |       |       |
| 25           | ON               | OFF   | OFF   | ON    | ON    | OFF   |       |       |
| 26           | OFF              | ON    | OFF   | ON    | ON    | OFF   |       |       |
| 27           | ON               | ON    | OFF   | ON    | ON    | OFF   |       |       |
| 28           | OFF              | OFF   | ON    | ON    | ON    | OFF   |       |       |
| 29           | ON               | OFF   | ON    | ON    | ON    | OFF   |       |       |
| 30           | OFF              | ON    | ON    | ON    | ON    | OFF   |       |       |
| 31           | ON               | ON    | ON    | ON    | ON    | OFF   |       |       |
| 32           | OFF              | OFF   | OFF   | OFF   | OFF   | ON    |       |       |
| 33           | ON               | OFF   | OFF   | OFF   | OFF   | ON    |       |       |
| 34           | OFF              | ON    | OFF   | OFF   | OFF   | ON    |       |       |
| 35           | ON               | ON    | OFF   | OFF   | OFF   | ON    |       |       |
| 36           | OFF              | OFF   | ON    | OFF   | OFF   | ON    |       |       |
| 37           | ON               | OFF   | ON    | OFF   | OFF   | ON    |       |       |
| 38           | OFF              | ON    | ON    | OFF   | OFF   | ON    |       |       |
| 39           | ON               | ON    | ON    | OFF   | OFF   | ON    |       |       |
| 40           | OFF              | OFF   | OFF   | ON    | OFF   | ON    |       |       |
| 41           | ON               | OFF   | OFF   | ON    | OFF   | ON    |       |       |
| 42           | OFF              | ON    | OFF   | ON    | OFF   | ON    |       |       |
| 43           | ON               | ON    | OFF   | ON    | OFF   | ON    |       |       |
| 44           | OFF              | OFF   | ON    | ON    | OFF   | ON    |       |       |
| 45           | ON               | OFF   | ON    | ON    | OFF   | ON    |       |       |
| 46           | OFF              | ON    | ON    | ON    | OFF   | ON    |       |       |
| 47           | ON               | ON    | ON    | ON    | OFF   | ON    |       |       |
| 48           | OFF              | OFF   | OFF   | OFF   | ON    | ON    |       |       |
| 49           | ON               | OFF   | OFF   | OFF   | ON    | ON    |       |       |
| 50           | OFF              | ON    | OFF   | OFF   | ON    | ON    |       |       |
| 51           | ON               | ON    | OFF   | OFF   | ON    | ON    |       |       |
| 52           | OFF              | OFF   | ON    | OFF   | ON    | ON    |       |       |
| 53           | ON               | OFF   | ON    | OFF   | ON    | ON    |       |       |
| 54           | OFF              | ON    | ON    | OFF   | ON    | ON    |       |       |
| 55           | ON               | ON    | ON    | OFF   | ON    | ON    |       |       |
| 56           | OFF              | OFF   | OFF   | ON    | ON    | ON    |       |       |
| 57           | ON               | OFF   | OFF   | ON    | ON    | ON    |       |       |
| 58           | OFF              | ON    | OFF   | ON    | ON    | ON    |       |       |
| 59           | ON               | ON    | OFF   | ON    | ON    | ON    |       |       |
| 60           | OFF              | OFF   | ON    | ON    | ON    | ON    |       |       |
| 61           | ON               | OFF   | ON    | ON    | ON    | ON    |       |       |
| 62           | OFF              | ON    | ON    | ON    | ON    | ON    |       |       |
| 63           | ON               | ON    | ON    | ON    | ON    | ON    |       |       |

FX-200X-XX Network Main Board Address Setting

Leave in "OFF" position as Factory Set.

Leave in "OFF" position as Factory Set.

**ANC-5000 Board with Ethernet Port, Address Setting (DIP SWITCH SW1)**

| ANC-5000 | ADDR | SW1-1 | SW1-2 | SW1-3 | SW1-4 | SW1-5 | SW1-6 | SW1-7 | SW1-8 |
|----------|------|-------|-------|-------|-------|-------|-------|-------|-------|
|          | 1    | OFF   | OFF   | OFF   | OFF   | OFF   | OFF   | OFF   | ON    |
|          | 2    | OFF   | OFF   | OFF   | OFF   | OFF   | OFF   | ON    | OFF   |
|          | 3    | OFF   | OFF   | OFF   | OFF   | OFF   | OFF   | ON    | ON    |
|          | 4    | OFF   | OFF   | OFF   | OFF   | OFF   | ON    | OFF   | OFF   |
|          | 5    | OFF   | OFF   | OFF   | OFF   | OFF   | ON    | OFF   | ON    |
|          | 6    | OFF   | OFF   | OFF   | OFF   | OFF   | ON    | ON    | OFF   |
|          | 7    | OFF   | OFF   | OFF   | OFF   | OFF   | ON    | ON    | ON    |

**ANC-5000 Board without Ethernet Port, Address Setting (DIP SWITCH SW1)**

| ANC-5000 | ADDR | SW1-1 | SW1-2 | SW1-3 | SW1-4                                   | SW1-5 | SW1-6 | SW1-7 | SW1-8 |
|----------|------|-------|-------|-------|---|-------|-------|-------|-------|
|          | 1    | ON    | OFF   | OFF   | Leave in "OFF" position as Factory Set. |       |       |       |       |
|          | 2    | OFF   | ON    | OFF   |   |       |       |       |       |
|          | 3    | ON    | ON    | OFF   |   |       |       |       |       |
|          | 4    | OFF   | OFF   | ON    |   |       |       |       |       |
|          | 5    | ON    | OFF   | ON    |   |       |       |       |       |
|          | 6    | OFF   | ON    | ON    |   |       |       |       |       |
|          | 7    | ON    | ON    | ON    |   |       |       |       |       |

**ACN-792M Loop Adder Module (CPU) Address Setting (DIP SWITCH SW1)**

| ALCN-792M | ADDR | SW1-1 | SW1-2 | SW1-3 | SW1-4 | SW1-5 | SW1-6 | SW1-7 | SW1-8 |
|-----------|------|-------|-------|-------|-------|-------|-------|-------|-------|
|           | 1    | ON    | OFF   | OFF   | OFF   | OFF   | OFF   | OFF   | OFF   |
|           | 2    | OFF   | ON    | OFF   | OFF   | OFF   | OFF   | OFF   | OFF   |
|           | 3    | ON    | ON    | OFF   | OFF   | OFF   | OFF   | OFF   | OFF   |
|           | 4    | OFF   | OFF   | ON    | OFF   | OFF   | OFF   | OFF   | OFF   |
|           | 5    | ON    | OFF   | ON    | OFF   | OFF   | OFF   | OFF   | OFF   |
|           | 6    | OFF   | ON    | ON    | OFF   | OFF   | OFF   | OFF   | OFF   |
|           | 7    | ON    | ON    | ON    | OFF   | OFF   | OFF   | OFF   | OFF   |

Put in "ON" position for firmware restore to defaults during power up. At all other times put in "OFF" state.

**RAXN-LCD/RAXN-LCDG Remote Annunciator Address Setting (DIP SWITCH SW1)**

| RAXN-LCD/G | ADDR | SW1-1 | SW1-2 | SW1-3 | SW1-4 | SW1-5 | SW1-6 | SW1-7                                   | SW1-8 |
|------------|------|-------|-------|-------|-------|-------|-------|---|-------|
|            | 33   | ON    | OFF   | OFF   | OFF   | OFF   | ON    | Leave in "OFF" position as Factory Set. |       |
|            | 34   | OFF   | ON    | OFF   | OFF   | OFF   | ON    |   |       |
|            | 35   | ON    | ON    | OFF   | OFF   | OFF   | ON    |   |       |
|            | 36   | OFF   | OFF   | ON    | OFF   | OFF   | ON    |   |       |
|            | 37   | ON    | OFF   | ON    | OFF   | OFF   | ON    |   |       |
|            | 38   | OFF   | ON    | ON    | OFF   | OFF   | ON    |   |       |
|            | 39   | ON    | ON    | ON    | OFF   | OFF   | ON    |   |       |

**Appendix D: Alarm Verification Timing**

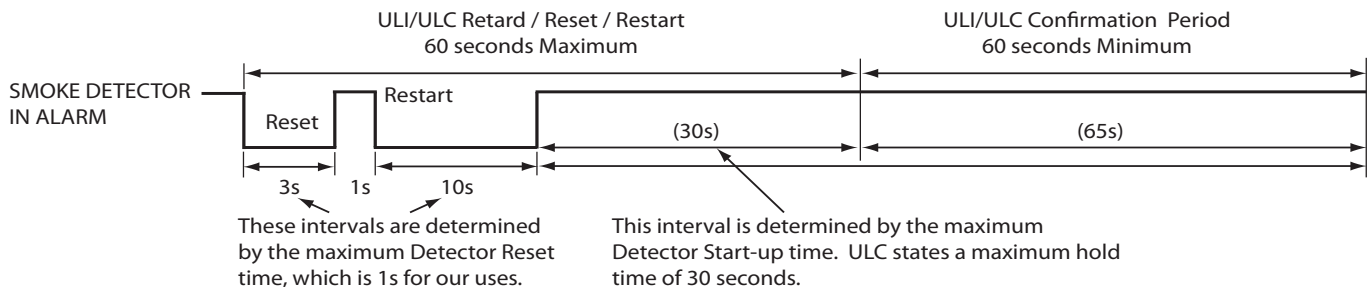

A Manual Station, or other contact-closure device, would remain shorted and be detected during the very short Zone Power burst within the first three seconds. A Smoke Detector will have been reset, and will require some minimum time to power-up, thus the Verification cycle will be entered.

# Appendix E: Wiring For Addressable Supervised Output Module

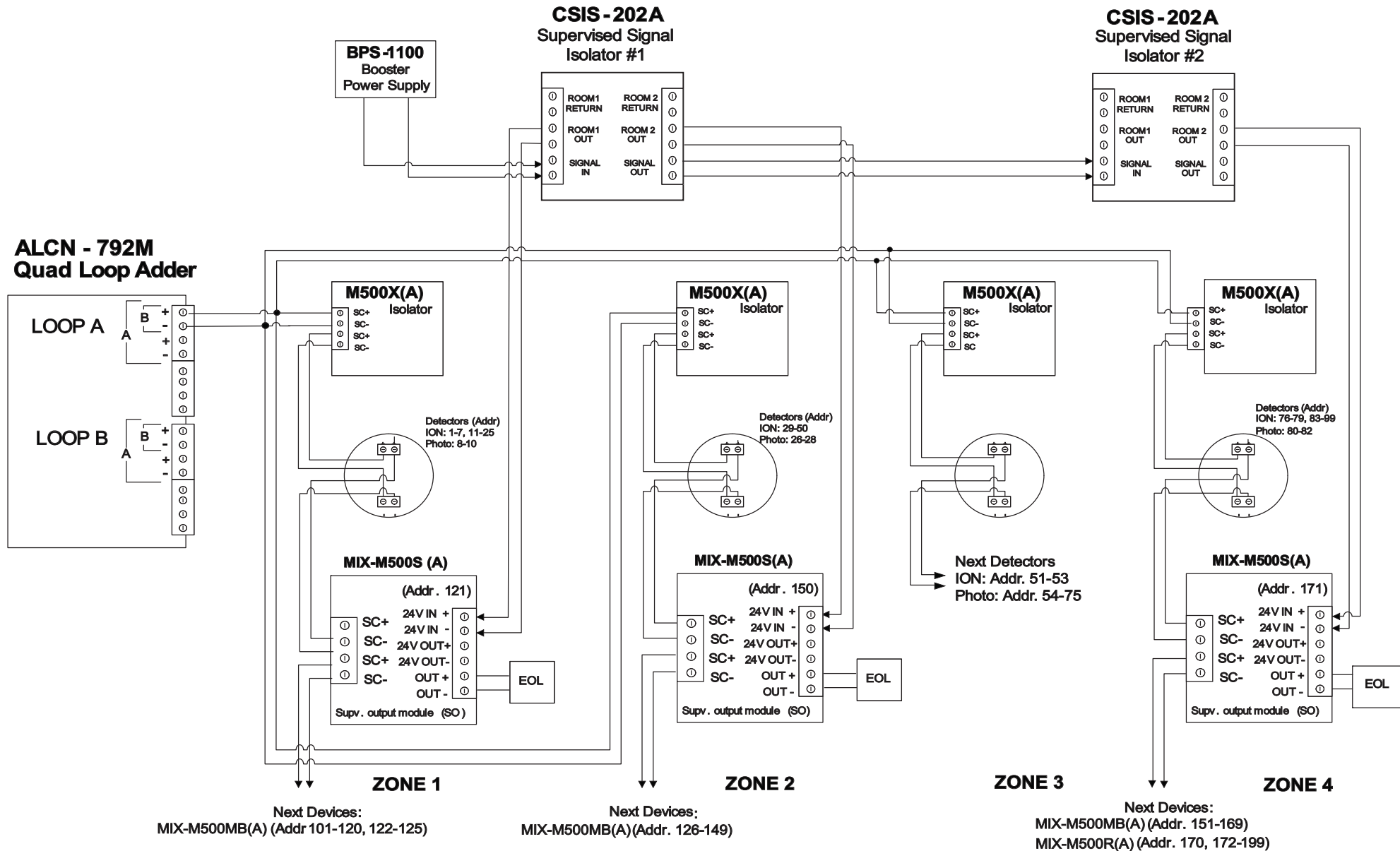

WIRING FOR ADDRESSABLE SUPERVISED OUTPUT MODULE TO COMPLY WITH UL 864 REV. 9

## Appendix F: ULC Compatible Speakers

| MIRCOM MODEL NUMBER               | dbA @ 10 feet                             |                                      | Mounting and Shape              |           |
|-----------------------------------|---|--------------------------------------|---------------------------------|-----------|
| <b>4" Speakers (70V)</b>          |   |                                      |                                 |           |
| SP-104A-70 (4"round)              | 1/4 watt                                  | 85 dbA                               | IB-104 Recessed                 | Round     |
| SP-204A-70 (4"square)             | 1/2 watt                                  | 86 dbA                               | IB-204 Recessed, IB-404 Surface | Square    |
|                                   | 1 watt                                    | 89 dbA                               |                                 |           |
| SP-304A-70 (retrofit)             | 2 watts                                   | 91 dbA                               | IB-604 Recessed                 | Rectangle |
| <b>Strobe Speakers (70V)</b>      |   |                                      |                                 |           |
| SPS-104A-70 (4"round)             | 1/4 watt                                  | 85 dbA                               | IB-104 Recessed                 | Round     |
| SPS-204A-70 (4"square)            | 1/2 watt                                  | 86 dbA                               | IB-204 Recessed, IB-404 Surface | Square    |
|                                   | 1 watt                                    | 89 dbA                               |                                 |           |
|                                   | 2 watts                                   | 91 dbA                               |                                 |           |
| <b>Silenceable Speakers (70V)</b> |   |                                      |                                 |           |
| SP-404-70A (4"round)              | 1/4 watt<br>1/2 watt<br>1 watt<br>2 watts | 85 dbA<br>86 dbA<br>89 dbA<br>91 dbA | IB-104 Recessed                 | Round     |
| SP-504-70A (4"square)             |   |                                      | IB-204 Recessed, IB-404 Surface | Square    |
| SP-404SW-70A (4"round)            |   |                                      | IB-104 Recessed                 | Round     |
| SP-504SW-70A (4"square)           |   |                                      | IB-204 Recessed, IB-404 Surface | Square    |
| <b>8" Speakers (70V)</b>          |   |                                      |                                 |           |
| SP-108-70 (8"round)               | 1/4 watt                                  | 83 dbA                               | IB-108 Recessed                 | Round     |
| SP-208-70 (8"square)              | 1/2 watt                                  | 87 dbA                               | IB-208 Recessed, IB-408 Surface | Square    |
|                                   | 1 watt                                    | 90 dbA                               |                                 |           |
|                                   | 2 watts                                   | 93 dbA                               |                                 |           |

## Appendix G: ULI Compatible Speakers

| COOPER-WHEELOCK MODEL NUMBER   | dbA @ 10 feet   |  | Mounting and Shape  |
|--|---|--|---|
| <b>Square Speakers (25V or 70V)</b>  |   |  |   |
| E50-R (red)<br>E50-W (white)   | 1/8 watt<br>1/4 watt<br>1/2 watt<br>1 watt<br>2 watts | 77 dBA<br>81 dbA<br>83 dbA<br>86 dbA<br>89dbA  | Standard Electrical Box, 5" square speaker  |
| <b>Rectangular Speaker/Strobe (25V or 70V)</b>   |   |  |   |
| E50-241575W-FR (red)<br>E50-241575W-FW (white)<br>E50-24MCW-FR (red)<br>E50-24MCW-FW (white) | 1/8 watts<br>1/4 watts<br>1/2 watts                   | 76 dBA<br>80 dbA<br>82 dbA                     | Standard Electrical Box with extension ring, 5"W x 6.74" rectangular speaker/strobe |
| E50-24MCW-MW (white)<br>E50-24MCWH-FR (red)<br>E50-24MCWH-FW (white)                         | 1 watts<br>2 watts                                    | 85 dbA<br>88 dbA                               |   |
| <b>Round Speaker (25V or 70V)</b>  |   |  |   |
| E60-R (red)<br>E60-W (white)   | 1/8 watt<br>1/4 watt<br>1/2 watt<br>1 watt<br>2 watt  | 77 dBA<br>81 dbA<br>83 dbA<br>86 dbA<br>89dbA  | Standard Electrical Box, 7.385" round speaker                                       |
| <b>Round Speaker/Strobe (25V or 70V)</b>   |   |  |   |
| E60-24MCC-FR (red)<br>E60-24MCC-FW (white)<br>E60-24MCCH-FR (red)<br>E60-24MCCH-FW (white)   | 1/8 watt<br>1/4 watt<br>1/2 watt<br>1 watt<br>2 watts | 76 dBA<br>80 dbA<br>82 dbA<br>85 dbA<br>88 dbA | Standard Electrical Box with extension ring 7.385" round                            |

# Appendix H: Power Supply & Batteries for Audio

Use the form below to determine the required main chassis and secondary power supply (batteries).

The main AC branch circuit connection for Fire Alarm Control Unit must provide a dedicated continuous power without provision of any disconnect devices. Use #12 AWG wire with 600-volt insulation and proper over-current circuit protection that complies with the local codes. Refer to *Appendix A* for specifications.

| Model Number                                      | Description                         | Qty |   | Standby (Amps) | Total Standby (Amps) | Alarm (Amps) | Total Alarm (Amps) |
|---|-------------------------------------|-----|---|----------------|----------------------|--------------|--------------------|
| FX-2000MNS  | Main Fire Alarm Board               |     | X | 0.310          | =                    | 0.733        | =                  |
| ANC-5000  | Audio Network Controller Module     |     | X | 0.255          | =                    | 0.265        | =                  |
| TNC-5000  | Telephone Network Controller Module |     | X | 0.195          | =                    | 0.215        | =                  |
| QAA-5160-70/25                                    | 1 Zone 60W Amplifier                |     | X | 0.055          | =                    | 0.350        | =                  |
| QAA-5230-70/25                                    | 2 Zone 30W Amplifier                |     | X | 0.055          | =                    | 0.350        | =                  |
| QAA-5230S-70/25                                   | 2 Zone 30W Amplifier (split)        |     | X | 0.055          | =                    | 0.350        | =                  |
| QAA-5415-70                                       | 4 Zone 15W Amplifier, 70V           |     | X | 0.055          | =                    | 0.350        | =                  |
| QAA-5415-25                                       | 4 Zone 15W Amplifier, 25V           |     | X | 0.055          | =                    | 0.350        | =                  |
| QMP-5101N   | Master Paging Module                |     | X | 0.003          | =                    | 0.007        | =                  |
| QMP-5101NV  | Vertical Master Paging Module       |     | X | 0.003          | =                    | 0.007        | =                  |
| QMT-5302N   | Master Telephone Module             |     | X | 0.001          | =                    | 0.013        | =                  |
| QMT-5302NV  | Vertical Master Telephone Module    |     | X | 0.001          | =                    | 0.013        | =                  |
| QAZT-5302/DS                                      | Paging/Telephone Zone Module        |     | X | 0.010/0.005    | =                    | 0.015/0.022  | =                  |
| Total audio power in watts                        |                                     |     |   |                |                      | 0.065/watt   | =                  |
| Total audio power in watts for QAA-5415-70 or -25 |                                     |     |   |                |                      | 0.075/watt   | =                  |
| Total currents (Add above currents)               |                                     |     |   |                | STANDBY (A)          |              | (B)                |

**Total Current Requirement: ALARM (B) \_\_\_\_\_ Amps.**

### Battery Capacity Requirement

$$((\text{STANDBY (A) } \_\_\_\_\_\_] \times [(\text{24 or 60 Hours}) \_\_\_\_\_\_]) + ([\text{ALARM (B) } \_\_\_\_\_\_] \times [*\text{Alarm in Hr.}] \_\_\_\_\_\_) = (\text{C}) \_\_\_\_\_\_ \text{ AH}$$

**Battery Selection: Multiply answer above (C) by 1.20 to derate battery.**

**Batteries:** BAT-12V26 (26AH), BAT-12V42 (42AH), and BAT-12V55(55AH).

**Above 42AH, batteries require a separate box (model BC-160).**

\* Use **0.084** for five minutes of alarm or **0.5** for thirty minutes of alarm as a multiplier figure.



**Note:** Separate calculations must be completed for each QBB-5001(R).

## Appendix I: FXMNS Used as a Mass Notification System (ACU)

The MNS portion of a complete Mircom FleX-Net™ Network Fire Alarm system consists of a BBX-FXMNS Enclosure (see Node 2 in figure below). The BBX-FXMNS includes a RAXN-LCD Annunciator which is designated an ACU (Autonomous Control Unit) and a Master Microphone to provide emergency audio. Below the ACU is another RAXN-LCD which annunciates the fire alarm system along with a Master Telephone for emergency use. Below this is a display LCD such as the DSPL-420 or DSPL-2440 which may be used for service; this display will show all messages. Up to seven FX-LOC(R)s can be connected to any MNS node.

The FX-LOC(R) Local Operating Console along with the FleX-Net™ Network Fire Alarm provides compliance with the Mass Notification System (MNS) UL 2572 requirements.

### Applicable Standards: UL 2572, UL 864, NFPA 72, ULC

Figure 83: In-Building Mass Notification Sample System

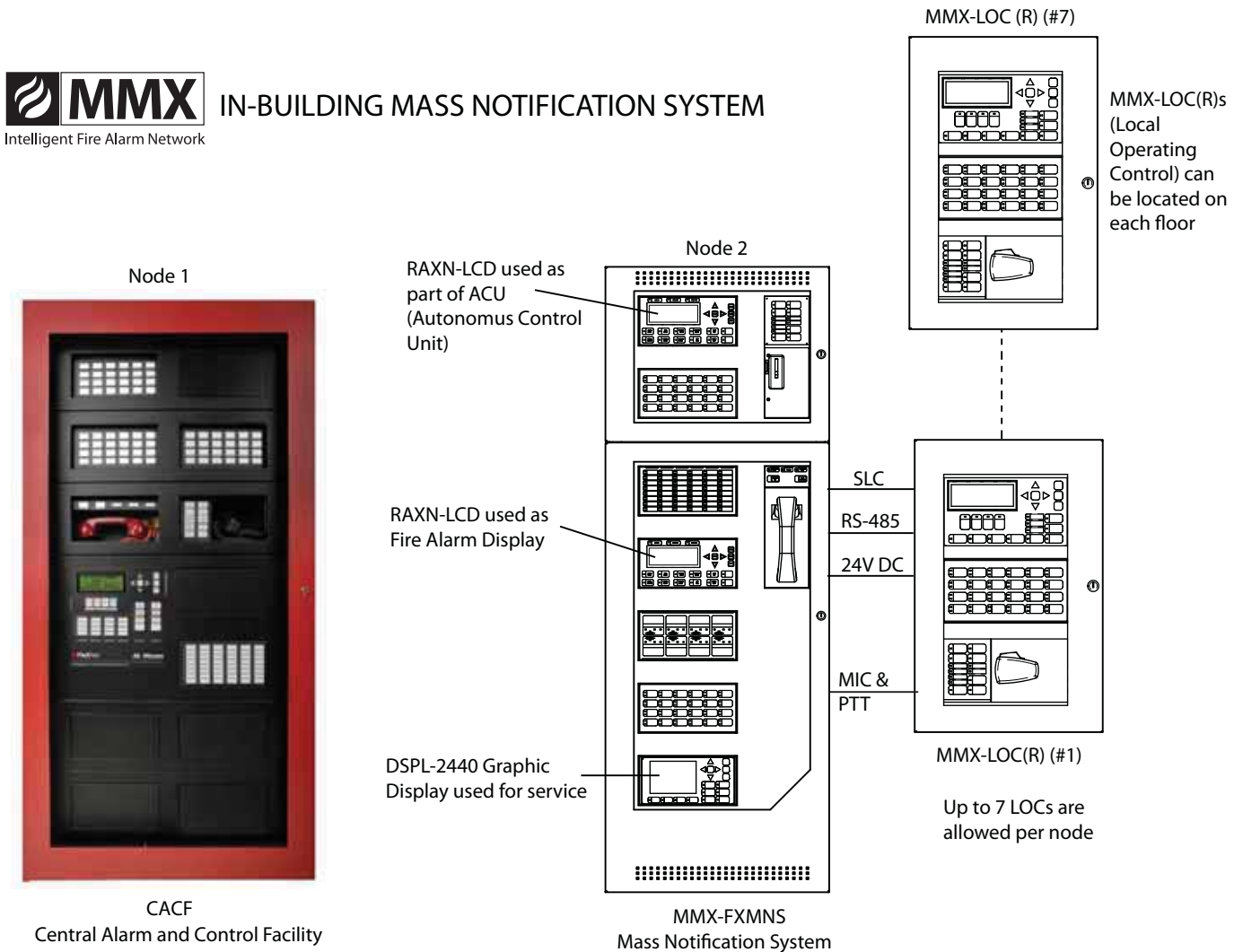

# QMP-5101N Network Paging Wiring for Mass Notification

Figure 84: QMP-5101N Network Master Paging Control Module Wiring to the ANC-5000 Audio Network Controller Module

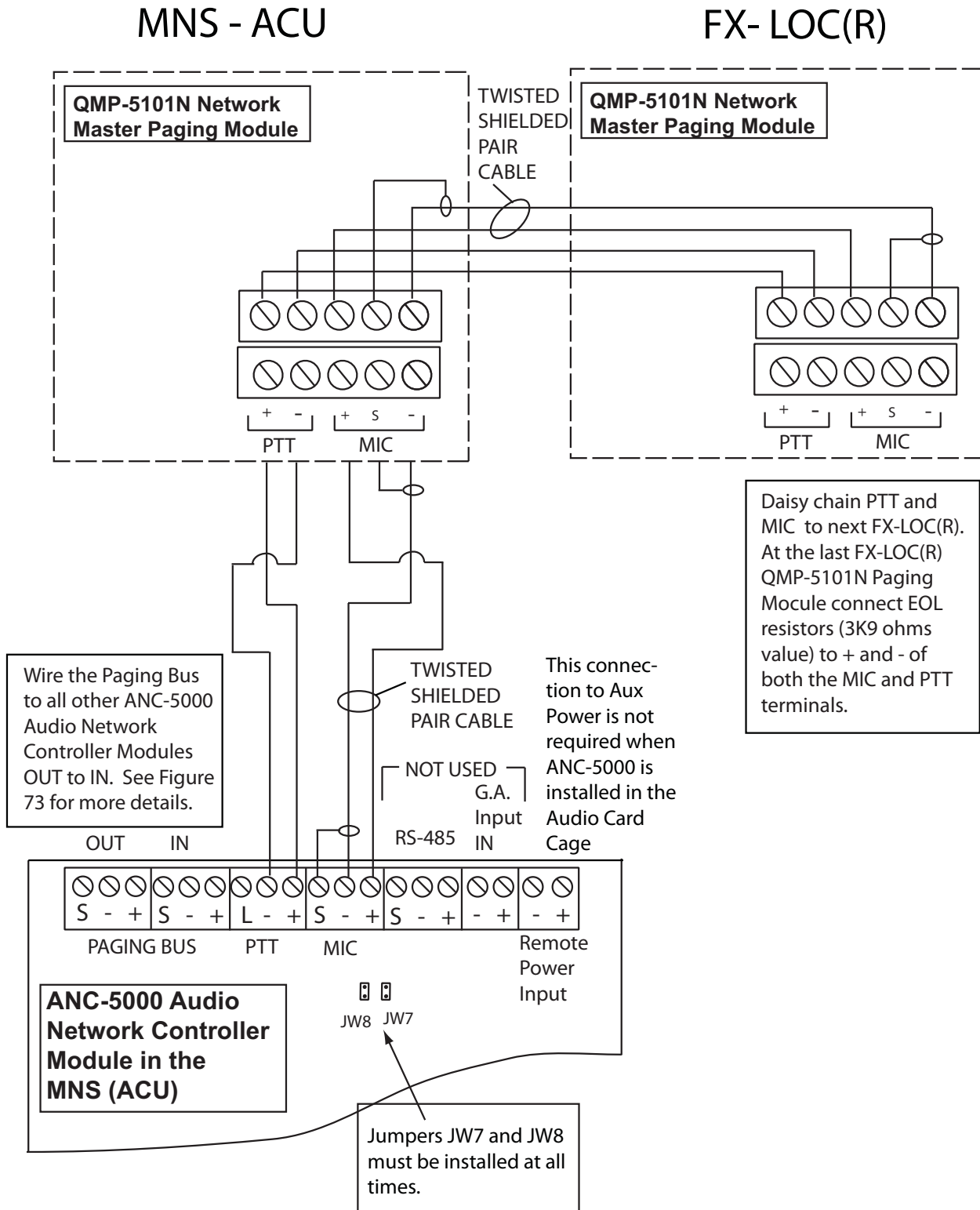



## Configuration for Mass Notification

There are two groups that can be created for the nodes; one group is the fire/central control and the second is mass notification.

In order to have this distinction, all zones have to be assigned a “Zone Priority”. Priority can be high, low, normal or a percentage of + or - increments of 5. Maximum of +95 percent above normal and -95 percent below normal. This percentage allows specific levels of messaging priority above and below fire alarm messaging. For example one area of voice messaging may have +5 percent above normal zone priority, which means that this area has the first level priority (or override) above fire alarm messaging. Another area may have -10 percent below normal zone priority which will have this area two levels below fire alarm messaging priority.

The following are screen captures of the group and zone priority for an sample system with a CACF and MNS and two FX-LOC(R)s (refer to figure on page 139).

This screen capture shows selection of Node 1 as a Fire/Central Control

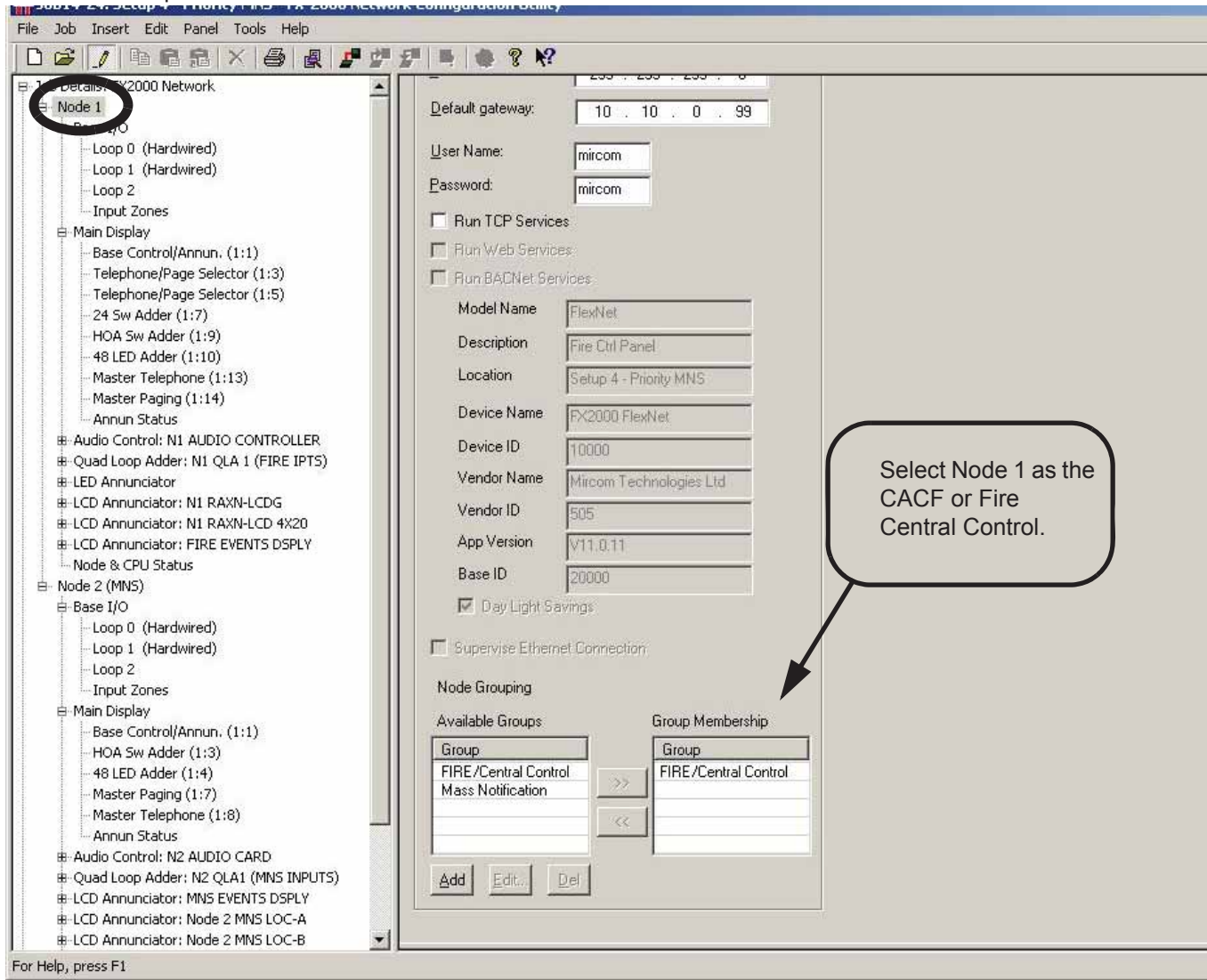

This screen capture shows selection of Node 2 as Mass Notification

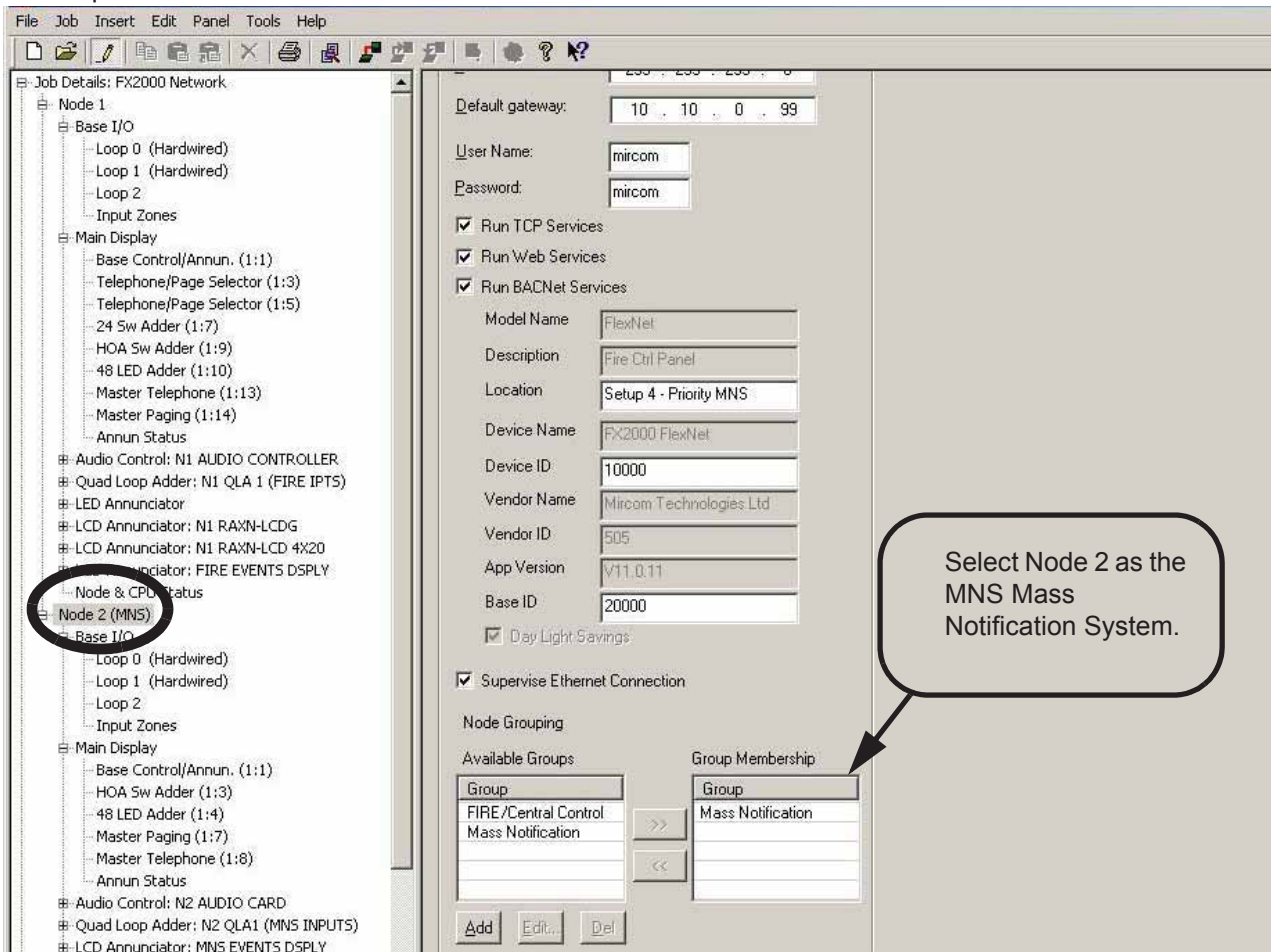

This screen capture shows input zone priority settings for the Mass Notification Node 2

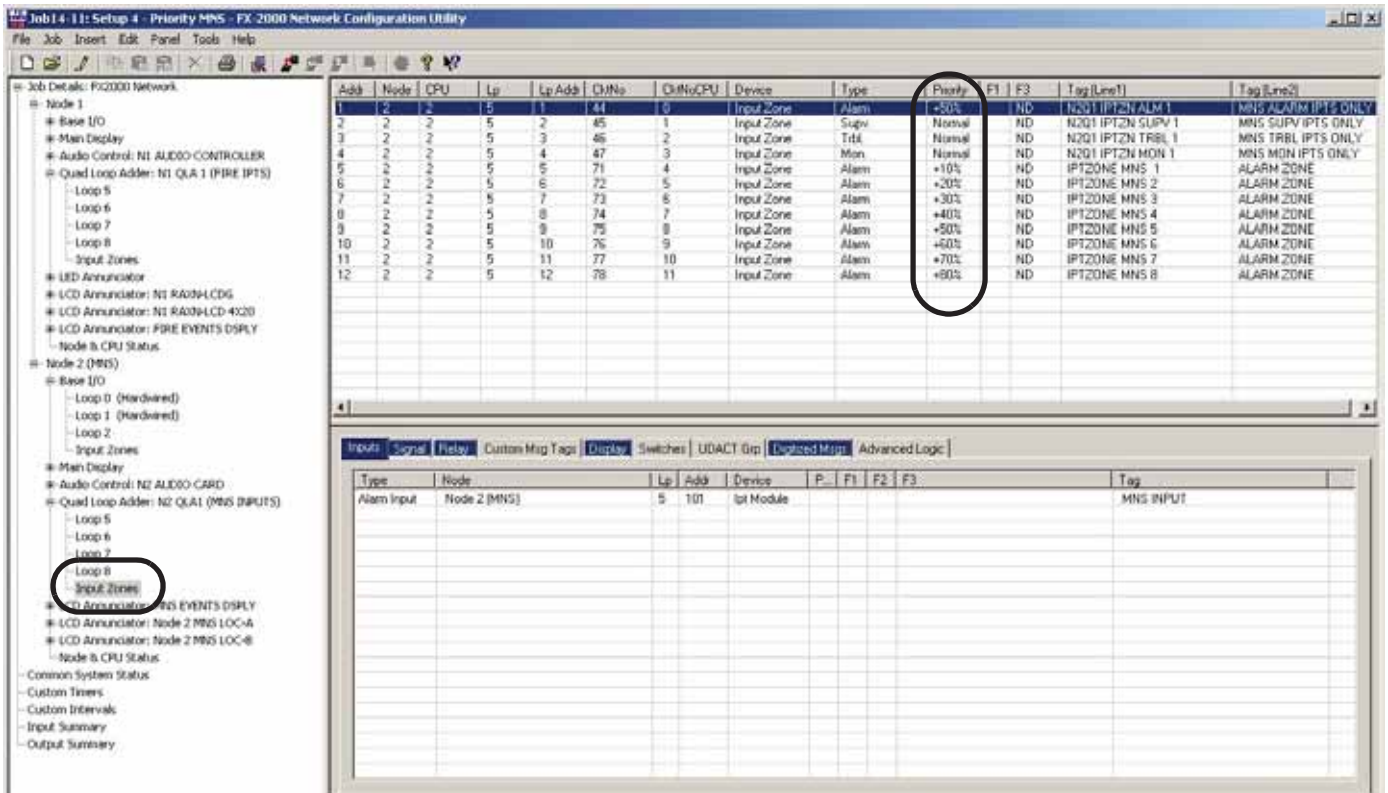

### FX-LOC(R) Active

As part of the Mass Notification requirements, an RAX-1048TZDS Zone Annunciator is part of the MNS. Configure one zone of the RAX-1048TZDS per each FX-LOC(R) connected to the MNS (ACU). Each LED is configured to illuminate when the respective FX-LOC(R) paging is in use.

**Note:** The RAX-1048TZDS normally displays Initiating circuit status and trouble indication, the Flex-Net™ configuration must be used to configure each zone corresponding to a FX-LOC(R).

### Reset

As per UL, resets are handled separately for Fire/Central Control and the Mass Notification System. They are mutually independent.

## ACU Emergency Response Operation

1. Access control of ACU.
2. ACU will notify in use via LED on RAX-1048TZDS.
3. Select areas to receive paging or digitized messages or use all call.
4. Page or send digitized message as necessary.

## Appendix J: APB-200/COA Sounder Bases

The FleX-Net™ Network Fire Alarm system can accommodate up to 32 APB-200/COA sounder bases per panel (node). The sounder base audio is synchronized on the same loop basis.

Below is a wiring diagram for connecting the sounder bases to auxiliary power with supervision.

**Figure 85: Sounder Base Wiring to Auxiliary Power Supply with Supervision**

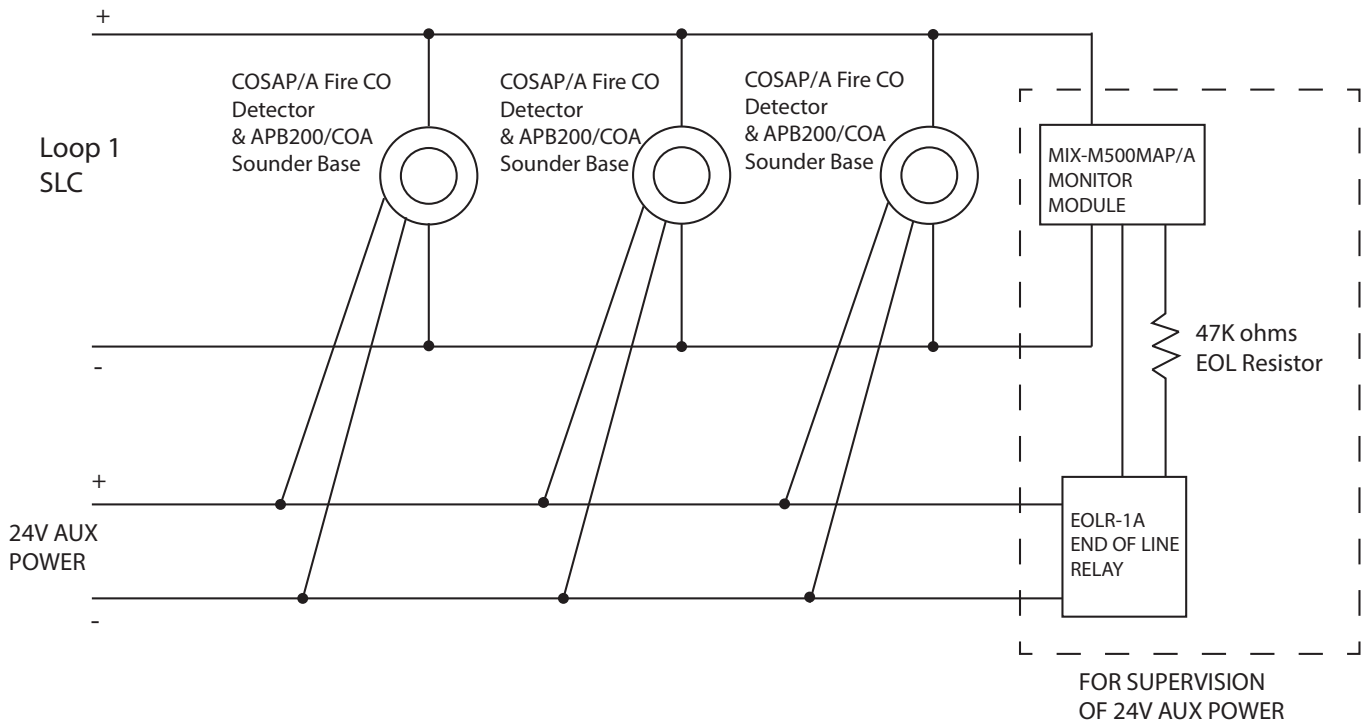

The monitor module (shown in the diagram above) should be set up in the configurator to report as a trouble input with the message tag "Sounder Base Fault".

# Warranty & Warning Information

---

## Warning Please Read Carefully

Note to End Users: This equipment is subject to terms and conditions of sale as follows:

### Note to Installers

This warning contains vital information. As the only individual in contact with system users, it is your responsibility to bring each item in this warning to the attention of the users of this system. Failure to properly inform system end-users of the circumstances in which the system might fail may result in over-reliance upon the system. As a result, it is imperative that you properly inform each customer for whom you install the system of the possible forms of failure.

### System Failures

This system has been carefully designed to be as effective as possible. There are circumstances, such as fire or other types of emergencies where it may not provide protection. Alarm systems of any type may be compromised deliberately or may fail to operate as expected for a variety of reasons. Some reasons for system failure include:

#### •*Inadequate Installation*

A Fire Alarm system must be installed in accordance with all the applicable codes and standards in order to provide adequate protection. An inspection and approval of the initial installation, or, after any changes to the system, must be conducted by the Local Authority Having Jurisdiction. Such inspections ensure installation has been carried out properly.

#### •*Power Failure*

Control units, smoke detectors and many other connected devices require an adequate power supply for proper operation. If the system or any device connected to the system operates from batteries, it is possible for the batteries to fail. Even if the batteries have not failed, they must be fully charged, in good condition and installed correctly. If a device operates only by AC power, any interruption, however brief, will render that device inoperative while it does not have power. Power interruptions of any length are often accompanied by voltage fluctuations which may damage electronic equipment such as a fire alarm system. After a power interruption has occurred, immediately conduct a complete system test to ensure that the system operates as intended.

#### •*Failure of Replaceable Batteries*

Systems with wireless transmitters have been designed to provide several years of battery life under normal conditions. The expected battery life is a function of the device environment, usage and type. Ambient conditions such as high humidity, high or low temperatures, or large temperature fluctuations may reduce the expected battery life. While each transmitting device has a low battery monitor which identifies when the batteries need to be replaced, this monitor may fail to operate as expected. Regular testing and maintenance will keep the system in good operating condition.

#### •*Compromise of Radio Frequency (Wireless) Devices*

Signals may not reach the receiver under all circumstances which could include metal objects placed on or near the radio path or deliberate jamming or other inadvertent radio signal interference.

#### •*System Users*

A user may not be able to operate a panic or emergency switch possibly due to permanent or temporary physical disability, inability to reach the device in time, or unfamiliarity with the correct operation. It is important that all system users be trained in the correct operation of the alarm system and that they know how to respond when the system indicates an alarm.

#### •*Automatic Alarm Initiating Devices*

Smoke detectors, heat detectors and other alarm initiating devices that are a part of this system may not properly detect a fire condition or signal the control panel to alert occupants of a fire condition for a number of reasons, such as: the smoke detectors or heat detector may have been improperly installed or positioned; smoke or heat may not

be able to reach the alarm initiating device, such as when the fire is in a chimney, walls or roofs, or on the other side of closed doors; and, smoke and heat detectors may not detect smoke or heat from fires on another level of the residence or building.

•*Software*

Most MGC products contain software. With respect to those products, MGC does not warranty that the operation of the software will be uninterrupted or error-free or that the software will meet any other standard of performance, or that the functions or performance of the software will meet the user's requirements. MGC shall not be liable for any delays, breakdowns, interruptions, loss, destruction, alteration or other problems in the use of a product arising out of, or caused by, the software.

Every fire is different in the amount and rate at which smoke and heat are generated. Smoke detectors cannot sense all types of fires equally well. Smoke detectors may not provide timely warning of fires caused by carelessness or safety hazards such as smoking in bed, violent explosions, escaping gas, improper storage of flammable materials, overloaded electrical circuits, children playing with matches or arson.

Even if the smoke detector or heat detector operates as intended, there may be circumstances when there is insufficient warning to allow all occupants to escape in time to avoid injury or death.

•*Alarm Notification Appliances*

Alarm Notification Appliances such as sirens, bells, horns, or strobes may not warn people or waken someone sleeping if there is an intervening wall or door. If notification appliances are located on a different level of the residence or premise, then it is less likely that the occupants will be alerted or awakened. Audible notification appliances may be interfered with by other noise sources such as stereos, radios, televisions, air conditioners or other appliances, or passing traffic. Audible notification appliances, however loud, may not be heard by a hearing-impaired person.

•*Telephone Lines*

If telephone lines are used to transmit alarms, they may be out of service or busy for certain periods of time. Also the telephone lines may be compromised by such things as criminal tampering, local construction, storms or earthquakes.

•*Insufficient Time*

There may be circumstances when the system will operate as intended, yet the occupants will not be protected from the emergency due to their inability to respond to the warnings in a timely manner. If the system is monitored, the response may not occur in time enough to protect the occupants or their belongings.

•*Component Failure*

Although every effort has been made to make this system as reliable as possible, the system may fail to function as intended due to the failure of a component.

•*Inadequate Testing*

Most problems that would prevent an alarm system from operating as intended can be discovered by regular testing and maintenance. The complete system should be tested as required by national standards and the Local Authority Having Jurisdiction and immediately after a fire, storm, earthquake, accident, or any kind of construction activity inside or outside the premises. The testing should include all sensing devices, keypads, consoles, alarm indicating devices and any other operational devices that are part of the system.

•*Security and Insurance*

Regardless of its capabilities, an alarm system is not a substitute for property or life insurance. An alarm system also is not a substitute for property owners, renters, or other occupants to act prudently to prevent or minimize the harmful effects of an emergency situation.

IMPORTANT NOTE: End-users of the system must take care to ensure that the system, batteries, telephone lines, etc. are tested and examined on a regular basis to ensure the minimization of system failure.

## Limited Warranty

Mircom Technologies Ltd., MGC Systems Corp. and MGC System International Ltd. together with their subsidiaries and affiliates (collectively, MGC) warrants the original purchaser that for a period of three years from the date of shipment, proprietary manufactured product shall be free of defects in materials and workmanship, under normal use. During the warranty period, MGC shall, at its option, repair or replace any defective product upon return of the product to its factory, at no charge for labor and materials. Non-proprietary, third party or OEM product shall be warranted in accordance with the warranty period of the manufacturer. Any replacement and/or repaired parts are warranted for the remainder of the original warranty or ninety (90) days, whichever is longer. The original owner must promptly notify MGC in writing that there is defect in material or workmanship, such written notice to be received in all events prior to expiration of the warranty period.

### International Warranty

The warranty for international customers is the same as for any customer within Canada and the United States, MGC shall not be responsible for any customs fees, taxes, or VAT that may be due.

### Conditions to Void Warranty

This warranty applies only to defects in parts and workmanship relating to normal use. It does not cover:

- damage incurred in shipping or handling;
- damage caused by disaster such as fire, flood, wind, earthquake or lightning;
- damage due to causes beyond the control of MGC such as excessive voltage, mechanical shock or
- water damage;
- damage caused by unauthorized attachment, alterations, modifications or foreign objects;
- damage caused by peripherals (unless such peripherals were supplied by MGC);
- defects caused by failure to provide a suitable installation environment for the products;
- damage caused by use of the products for purposes other than those for which it was designed;
- damage from improper maintenance;
- damage arising out of any other abuse, mishandling or improper application of the products.

## Warranty Procedure

To obtain service under this warranty, please return the item(s) in question to the point of purchase. All authorized distributors and dealers have a warranty program. Anyone returning goods to MGC must first obtain an authorization number. MGC will not accept any shipment whatsoever for which prior authorization has not been obtained. NOTE: Unless specific pre-authorization in writing is obtained from MGC management, no credits will be issued for custom fabricated products or parts or for complete fire alarm system. MGC will at its sole option, repair or replace parts under warranty. Advance replacements for such items must be purchased.

Note: MGC's liability for failure to repair the product under this warranty after a reasonable number of attempts will be limited to a replacement of the product, as the exclusive remedy for breach of warranty.

## Disclaimer of Warranties

This warranty contains the entire warranty and shall be in lieu of any and all other warranties, whether expressed or implied (including all implied warranties of merchantability or fitness for a particular purpose) and of all other obligations or liabilities. MGC neither assumes nor authorizes any other person purporting to act on its behalf to modify or to change this warranty, or to assume for it any other warranty or liability concerning this product.

This disclaimer of warranties and limited warranty are governed by the laws of the province of Ontario, Canada.

## Out of Warranty Repairs

MGC will at its option repair or replace out-of-warranty products which are returned to its factory according to the following conditions. Anyone returning goods to MGC must first obtain an authorization number. MGC will not accept any shipment whatsoever for which prior authorization has not been obtained.

Products which MGC determines to be repairable will be repaired and returned. A set fee which MGC has predetermined and which may be revised from time to time, will be charged for each unit repaired.

Products which MGC determines not to be repairable will be replaced by the nearest equivalent product available at that time. The current market price of the replacement product will be charged for each replacement unit.

*The foregoing information is accurate as of the date of publishing and is subject to change or revision without prior notice at the sole discretion of the Company*

**WARNING: MGC recommends that the entire system be completely tested on a regular basis. However, despite frequent testing, and due to, but not limited to, criminal tampering or electrical disruption, it is possible for this product to fail to perform as expected.**

**NOTE: Under no circumstances shall MGC be liable for any special, incidental, or consequential damages based upon breach of warranty, breach of contract, negligence, strict liability, or any other legal theory. Such damages include, but are not limited to, loss of profits, loss of the product or any associated equipment, cost of capital, cost of substitute or replacement equipment, facilities or services, down time, purchaser's time, the claims of third parties, including customers, and injury to property.**

**MGC MAKES NO WARRANTY OF MERCHANTABILITY OR FITNESS FOR A PARTICULAR PURPOSE WITH RESPECT TO ITS GOODS DELIVERED, NOR IS THERE ANY OTHER WARRANTY, EXPRESSED OR IMPLIED, EXCEPT FOR THE WARRANTY CONTAINED HEREIN.**











CANADA - Main Office  
25 Interchange Way  
Vaughan, ON L4K 5W3  
Tel: (888) 660-4655  
(905) 660-4655  
Fax: (905) 660-4113

U.S.A  
4575 Witmer Industrial Estates  
Niagara Falls, NY 14305  
Tel: (888) 660-4655  
(905) 660-4655  
Fax: (905) 660-4113

TECHNICAL SUPPORT  
North America  
Tel: (888) Mircom5  
(888) 647-2665  
International  
Tel: (905) 647-2665

© Mircom 2016  
Printed in Canada  
Subject to change without prior notice

[www.mircom.com](http://www.mircom.com)